

**REDISTART MICRO
RSM6 SERIES
RSM6B SERIES
RSM7 SERIES
RSM7B SERIES
INSTRUCTION MANUAL**

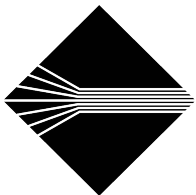

BENSHAW[®]
ADVANCED CONTROLS & DRIVES

QUICK START GUIDE

The following steps outline the electrical connections and basic programming of the starter to allow it to run a motor. This quick start guide should only be used as a reference. The rest of this manual in its entirety before power is applied to the starter.

- See page 22 before applying main power.
- Connect incoming power to terminals L1, L2, and L3.
- Connect the motor to terminals T1, T2, and T3.
- Connect 120Vac to the control power terminals if a transformer is not supplied. See the supplied diagram for the correct connections.
- Connect terminals to allow the use of the display Start and Stop buttons. Refer to page 14 for different Start/Stop wiring arrangements if another control method is desired.
- Check the settings of the burden select switches. The switches are mounted on the bottom left side of the Power card and have white sliders with a red body. See page 25 for a chart detailing the settings for different motor currents and CT ratios.
- Power can now be supplied to the starter.
- To enter the menus and change parameters, follow these steps. For more information refer to page 26. Press the menu key to select the desired menu and press the enter key to access that menu. Once in the menu, use the arrow keys to select the parameter to change. To change a parameter, press the enter key. Change the value that appears on the right by using the arrow keys and then store the value by pressing the enter key again.
- Enter Menu 1; Motor Data, and enter the actual motor nameplate current in the Motor FLA setting.
- Enter Menu 2; Starter Set-up, and scroll down to the CT Ratio setting. Confirm that this setting matches the ratio of the current transformers supplied with the starter.
- Enter Menu 3; Motor Protection, and check the overload class to ensure that it is set to the desired level of motor protection. The other protection features can also be checked even though the factory default values usually suffice.
- At this point in time, the starter is ready to be given a run command. Give a start command followed by a stop command to confirm the rotation of the motor. If the motor rotation is incorrect, swap any two incoming power or motor leads. If there was a long pause before the motor began to rotate, enter Menu 2; Starter Set-up, and set the Initial Current 50% higher than it was. Continue doing this until the motor begins to rotate within a couple of seconds of giving a start command.
- Give the starter a Run command. The motor should now begin rotating immediately and accelerate to full speed. If the motor doesn't accelerate correctly, then see page 38 for fine tuning details.
- The starter should now be set-up to properly start the motor. The starter can now be put into operation even though it is advisable to read the rest of the manual to fully understand the starter operation.

TABLE OF CONTENTS

1. INTRODUCTION-	4
1.1 STARTER OPERATION	4
1.2 STANDARD FEATURES	5
1.3 ADVANCED FEATURES	6
1.3.1 Kick Current	6
1.3.2 Dual Ramps	6
1.3.3 Shear Pin Current	6
1.3.4 Under Current	6
1.3.5 Machine Ground Fault	7
1.3.6 Meters	7
1.3.7 Energy Saver	7
1.3.8 True Motor Stall (Optional)	7
1.3.9 Real Time Clock	7
1.3.10 Emergency Restart Capability	8
1.3.11 Jog At Set Speed	8
1.3.12 Low Inertia Brake	8
1.3.13 Anti-Windmilling/Anti-Condensate Heater	8
1.3.14 Synchronous Motor Control	8
1.4 DISPLAY	9
1.4.1 Display Meters	9
1.4.2 Operating Messages	10
2. DIAGRAMS	11
2.1 POWER CARD LAYOUT	11
2.2 COMPUTER CARD LAYOUT	12
2.3 DISPLAY/KEYPAD LAYOUT	13
2.4 RELAY CARD LAYOUT (OPTIONAL)	13
2.5 WIRING DIAGRAM	14
2.6 REVERSING/BRAKING CARD DIAGRAM	15
2.7 INTEGRAL BYPASS CARD LAYOUT	16
3. TECHNICAL DATA	17
3.1 SUPPLY VOLTAGES	17
3.2 CONTROL TERMINALS	17
3.2.1 Power Card	17
3.2.2 Computer Card	17
3.2.3 Relay Card	18
3.3 OUTPUT CONTACT RATINGS	18
3.4 OVERLOAD CURVES	19
4. INSTALLATION	20
4.1 SAFETY PRECAUTIONS	20
4.2 WIRING GUIDELINES	21
4.3 BEFORE APPLYING MAIN POWER	22
5. STARTER SET-UP	23
5.1 HARDWARE SETTING	23
5.1.1 Common Jumper Setting	23
5.1.2 Computer Card Jumpers	24
5.1.3 CPU 16 Pin Header Assignment (JC11)	25
5.1.4 CT Burden Select	25
5.2 PROGRAMMING THE REDISTART MICRO	26
5.2.1 Function Of Display Buttons	26
5.2.2 Parameter List	27

**REDISTART MICRO
INSTRUCTION MANUAL**

- 5.2.3 Detailed description of paramters - - - - - 29
- 5.3 FINE TUNING - - - - - 38
- 6. TROUBLESHOOTING - - - - - 39**
- 6.1 LED INDICATION - - - - - 39
- 6.2 FAULTS- - - - - 40
- 6.3 EVENT RECORDER - - - - - 40
- 6.4 CODES - - - - - 41
- 6.5 CONDITIONS - - - - - 43
- 6.6 TROUBLESHOOTING CHARTS - - - - - 43
- 6.6.1 Motor Will Not Start - No output voltage to the motor - - - - - 43
- 6.6.2 Motor Rotates (but does not accelerate to full speed) - - - - - 43
- 6.6.3 Decel Not Operating Correctly - - - - - 44
- 6.6.4 Motor Stops While Running- - - - - 44
- 6.6.5 Miscellaneous Situations- - - - - 45
- 7. SPARE PARTS- - - - - 46**
- 8. DISPLAY CUT-OUT - - - - - 48**

1. INTRODUCTION

1.1 STARTER OPERATION

The RediStart Micro is a microprocessor controlled solid state reduced voltage starter for three phase induction motors. The RediStart Micro operates on a user programmed current ramp for optimal motor control and protection. This type of operation is referred to as closed loop current control. The motor is accelerated from the initial current setting to the maximum current setting during the defined ramp time. Figure 1 depicts the standard operation mode of the RediStart Micro.

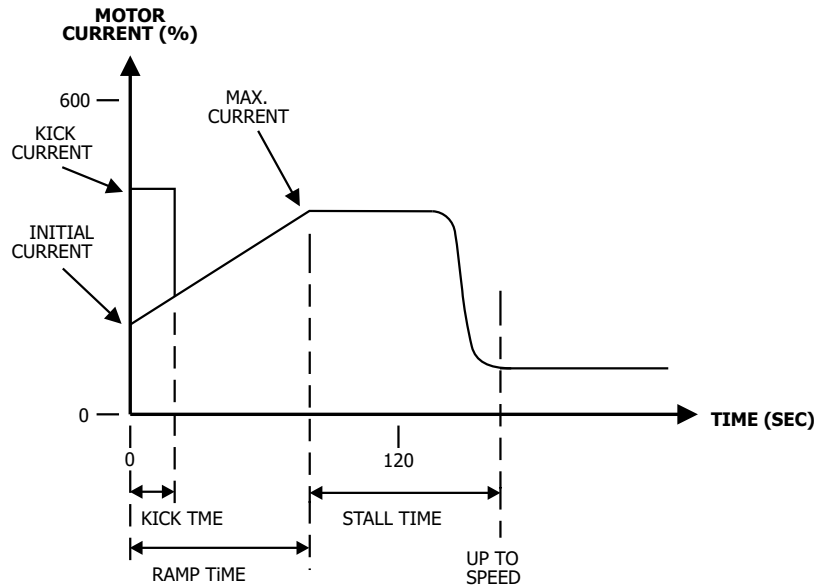

FIGURE 1: CURRENT RAMP

Once the starter has ramped the motor up to full speed it will pull-in the optional integral bypass contactors. The contactors will bypass the SCR's and since they provide a low resistance current path the power losses in the starter are significantly reduced. The integral bypass contactors are a definite purpose contactor and they can not be used to start the motor.

A current ramp is recommended for high inertia loads or applications where the power supply is not limited. For a current ramp, the maximum current setting should be left at 600%. This current setting allows the starter to deliver more than enough current to the motor to develop full motor torque.

NOTE: Even though the maximum current is set at 600%, this maximum will only be reached if the load requires 600% to achieve full speed. Ramp time is also a factor in determining whether or not maximum current is reached.

A constant current or current limit setting is recommended for light loads, or when the power supply is limited. The motor must not require full torque when accelerating the load. For this mode, the maximum current setting should be set to the current limit required to allow the motor to develop the proper starting torque. Set up should be done under worst case load conditions so that the motor will always accelerate even if the load changes.

1.2 STANDARD FEATURES

- Universal Voltage 200 to 600 Vac, 23 to 72 Hz, 3-phase, no adjustments.
- Chassis or NEMA 1, 4, 12, or 3R enclosure
- Benschaw Integral Bypass definite purpose contactors (RSM_B models)
- Electronic motor overload, class 5, 10, 15, 20, 25, 30, NA (not available), or BYP (bypass during start)
- Programmable motor service factor 1.0, 1.15, 1.25
- Adjustable stalled motor protection (off, 0 to 210 sec. current based, or 0 to 15 sec. true stall)
- Adjustable over/under voltage protection
- Adjustable line to line current imbalance protection
- Adjustable high and low frequency protection
- Single phase protection
- Adjustable starts per hour (off or 1 to 20 starts)
- Adjustable time between starts (off or 1 to 99 minutes)
- Backspin timer (off or 1 to 200 minutes)
- Programmable over current trip (50% to 800% or off) and time (0.0 to 90.0 sec. in 0.1 sec. intervals)
- Programmable under current trip (off or 10% to 100%) and time (0.0 to 90.0 sec. in 0.1 sec. intervals)
- Programmable machine ground fault trip (off or 1 to 100 amps) and time (0.0 to 90.0 sec. In 0.1 sec. intervals)
- Programmable over current, under current, and ground fault trips can each be set to indicate a fault or activate a relay
- Shorted SCR detection
- Phase rotation selectable ABC sensitive, CBA sensitive, or insensitive
- Emergency restart capability
- Two programmable ramp profiles selectable at any time via a 120volt input
- Initial and maximum current and ramp time adjustments for each ramp
- Ramp time adjustments for each ramp
- Kick current and time adjustments for each ramp
- D.C. brake current and time adjustments for each ramp
- Coast time adjustment for pause between stop command and application of D.C. Brake
- Zero speed input for removal of D.C. brake current
- Adjustable deceleration profile (to eliminate water hammer)
- Energy Saver (on or off)
- Programmable power factor or current control
- Local start/stop push buttons
- Plain English operation via back lit LCD display interface
- LCD and LED status and diagnostics (full fault annunciation)
- Programmable metering
- Programmable relay outputs
- Latched fault relay output (1 NO, 1NC form C)
- Real time clock
- Time stamped event recorder (stores 99 events)
- Battery backed-up menu parameters and lockout times
- Passcode protection

1.3 ADVANCED FEATURES

1.3.1 Kick Current

The kick current feature provides the user with the ability to override the current ramp profile for up to the first ten seconds of the current ramp. This feature can be used to start loads which have a high breakaway torque requirement. The kick current feature is enabled by changing the kick time from Off to the desired time. When the kick current feature is enabled, the starter will immediately go to the kick current level for the kick time. While the starter is in the kick current mode, Kicking or Kicking 2 will be displayed on the micro display depending on which ramp profile is selected.

1.3.2 Dual Ramps

The dual ramp feature allows the user to select between two separate programmable starting ramp profiles. The second ramp profile is activated by applying a 120 Vac signal to input terminal number 9 of JC13 on the micro computer card. Switching between ramp profiles may be done at any time during a motor start. Both current ramps are fully user adjustable and can be customized to adapt the starter to two different load conditions. The words Accel 2 or Kicking 2 will appear on the micro display when the second ramp is selected.

1.3.3 Shear Pin Current

The shear pin current feature allows the user to set a high current trip level and delay time. This allows the user to set a predetermined trip point, that allows the indication of an over-current condition or a starter trip, to protect equipment sensitive to jam or overload situations.

The starter can be set to either trip on a shear pin fault or activate a relay. When one or more of the programmable relays is set to SPT, the starter will activate a relay when a shear pin condition exists. The relay will remain active while the current is above the Shear Pin Current setting and remain active another ten seconds after the current falls below the shear pin current setting. This can be used to provide indication to feeding equipment to automatically unload a machine when an over-current situation occurs. When none of the programmable relays are set to SPT, the starter will shut down and display Fault 78 - Shear Pin Trip if a shear pin condition develops. This is useful to protect equipment that is sensitive to over-current situations.

The shear pin current trip is only activated once the starter reaches an Up-to-Speed condition. To protect the equipment from an over-current situation during the motor start, set the Maximum Current setting to the highest current that should reach the motor.

1.3.4 Under Current

The under current feature allows the user to select a low current trip level and delay time. This allows the user to set a predetermined trip point, that allows the indication of the under-current condition or a starter trip, to protect equipment, such as a water pump, that is sensitive to unloaded situations.

The starter can be set to either trip on an under current fault or activate a relay. When one or more of the programmable relays is set to UCT, the starter will activate a relay when an under-current condition exists. The relay will remain active while the current is below the under current-setting and reset after the current rises above the under-current setting. If none of the programmable relays are set to UCT, the starter will shut down and display Fault 79 - Under-Current Trip when an under current condition exists. This is useful to protect equipment that is sensitive to under-current situations. The under-current trip is activated once the starter reaches an Up-to-Speed condition.

Together, the shear pin and under current trips can be used as replacements for the stop/start buttons in a system to automatically stop and start a conveyor belt, or other equipment feeder, according to the current reaching the motor.

1.3.5 Machine Ground Fault

The machine ground fault protection allows the user to monitor the motor and wiring for machine ground faults. The starter performs the ground fault protection by monitoring the instantaneous sum of the three phase currents. This is often referred to as residual ground fault protection. The starter can be set to either trip and display a Fault 71 - Ground Fault, or to activate a relay (by programming a relay to GDF) when the machine ground fault conditions are met.

1.3.6 Meters

The starter has advanced metering. It can display any two of the following:

- Current or voltage of any single phase (A1, A2, A3, V1, V2, V3)
- Average current or voltage (Aavg or Vavg)
- Current or voltage of each phase in a scrolling mode (Ascr or Vscr)
- Frequency (Hz)
- Overload content (O/L)
- Power factor (pf)
- Elapsed time or motor operation time (etm)
- True power draw of the motor (W - watts)
- Energy consumption of the motor (WH - watt-hours)
- Reactive power draw of the motor (Var - volt-amps reactive)

The elapsed time meter will display time in tenths of an hour (xxxx.x format) and once it reaches 9999.9 hours, it will roll over. The other meters are all auto ranging. For example, once the watt meter reaches 5000W it will show 5kW and once it reaches 5000kW it will show 5MW. The elapsed time meter and watt-hour meter record internally when not selected so the values can be viewed at any time.

1.3.7 Energy Saver

The energy saver will automatically reduce the voltage applied to the motor under light load conditions. The voltage will be decreased until the motor current reaches its low point and begins to rise again and then the starter will regulate the voltage around that point. The starter will instantly apply full voltage to the motor when the load on the motor increases again. Potential true savings on unloaded motors are in the order of 1 kilowatt per 100 horsepower.

NOTE: The Energy Saver feature is not available on starters with bypass contactors since the contactor doesn't allow the SCR's to lower the output voltage and provide the energy saving.

1.3.8 True Motor Stall (Optional)

This feature monitors a zero speed switch to detect the stalled motor condition. The zero speed switch is connected to terminal 8 of JC13 on the micro computer card. The starter recognizes 120Vac applied as a motor zero speed indication. The starter will monitor the input for the removal of the 120Vac before the set stall time expires. If the stall time expires before the 120Vac signal is removed, the starter will shut down and display a Fault 74 - UTS Fault. To use the true motor stall protection, set a stall time with a "C" after it.

1.3.9 Real Time Clock

The starter has a battery backed-up real time clock that stores actual time and date. This feature allows the starter to keep track of the motor thermal overload, starter lockout times, and time stamps faults in the event recorder. The real-time clock is year 2000 compatible.

1.3.10 Emergency Restart Capability

The user can override the starter lockouts if it is necessary to start the motor. This feature is only to be used in an emergency when the process is more important than the motor. To perform an emergency restart, place a jumper across pins 6 and 11 of JC11 on the computer card, hold the enter key, and press the O/L reset button (SWC1) until the microprocessor resets. All lockouts will then be cleared.

1.3.11 Jog At Set Speed

The jog at set speed provides the starter with the ability to provide a cyclically converted reduced voltage and frequency to the starter. With 60Hz applied the starter can provide an apparent frequency of 4.6Hz (7.7%) or 8.6Hz (14.3%) for the forward direction or 12Hz (20%) for the reverse direction. The jog current can be selected in Menu 1 and is programmable from 50% to 250% of motor FLA. The speed of the forward jog is selected in Menu 1. The forward jog is selected by applying 120Vac to the JC13-4 input on the computer card and the reverse jog is selected by applying 120Vac to the JC13-5 input on the computer card. The starter doesn't have to be a reversing unit to be able to provide the 20% reverse jog.

Since the operation of a motor at a jog speed will reduce the cooling ability of the motor, the motor must be monitored to ensure that it doesn't overheat. The use of thermistors or RTDs to monitor the motor temperature is recommended. When setting up the starter to operate at a jog speed it is recommended to set the jog current to the lowest level possible that will maintain motor rotation. The ramp #2 kick current will operate when a forward jog is selected and it can be used to start the motor and load rotating.

1.3.12 Low Inertia Brake

The low inertia brake can be used to stop a motor with a light load. It is capable of providing a DC current up to 125% of the motor full load amp value and it can be used on systems with a low inertia load. The low inertia brake can be used by enabling the decel brake jumper (JPC3 to position 2-3) and then setting the brake torque and time in menu 2. The low inertia brake is enabled by placing a jumper across pins 7-10 and 2-15 of JC11 on the RediStart Micro CPU card.

1.3.13 Anti-Windmilling/Anti-Condensate Heater

The starter has the ability to provide a low level DC current to the motor while it is stopped. This can be used to hold the motor in position or heat the windings in the motor to prevent condensation from occurring inside the motor. To use this feature, apply 120Vac to the JC13-8 input and then give the starter a Run command. The level of current that reaches the motor is adjusted by the heater current parameter in menu 2. The anti-windmilling/anti-condensate heater is enabled by placing a jumper across pins 4-13 of JC11 on the RediStart Micro CPU card.

When this is being used, the motor should be monitored closely to ensure that it doesn't overheat while the DC current is applied. It is recommended to use thermistors or other protection devices in conjunction with this feature to ensure proper motor protection.

1.3.14 Synchronous Motor Control

The RediStart Micro is available with an optional synchronous motor control package which provides full synchronous motor control and protection

1.4 DISPLAY

The RediStart Micro comes with a display/keypad interface that allows the starter to be programmed using a simple, English interface. It also allows the user to view the current state of the starter, and when a fault occurs, it will give the fault code and a short description of the fault.

1.4.1 Display Meters

The RediStart Micro has two user programmable display meters. Meter #1 is displayed with units in the top right quadrant of the display. Meter #2 is displayed in the bottom right quadrant. The RediStart micro displays true RMS current. These values may not agree with standard ammeter or clamp on ammeter readings while the voltage is ramping.

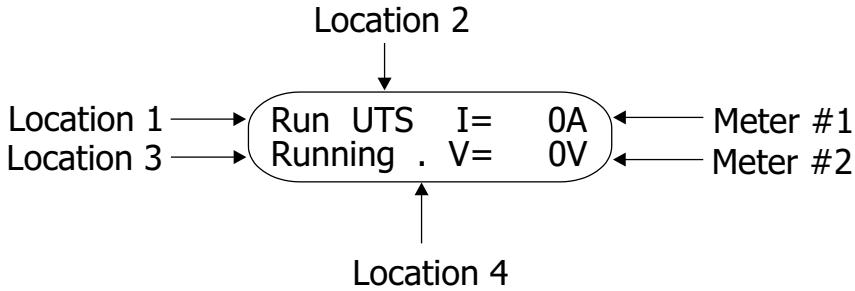

REDISTART MICRO INSTRUCTION MANUAL

1.4.2 Operating Messages

The RediStart Micro can display the following messages on the main display.

Message	Location	Description
STOP	1	Motor is not running, start command has not been given.
RUN	1	Motor is running, start command has been given.
FAULT	1	A fault has occurred, fault code and description will also be displayed.
UTS	2	Motor is at full speed and UTS contact is closed if enabled.
SYN	2	Motor is synchronized.
TBS	2	Time between starts is active.
xx.x min	3	The next start cannot be performed for xx.x minutes.
SPH	2	Starts per hour is active.
xx.x min	3	The next start cannot be performed for xx.x minutes.
BKS	2	Backspin timer is active.
xx.x min	3	The next start cannot be performed for xx.x minutes.
READY	3	All conditions OK to run, line voltage is present.
ACCEL	3	Motor is accelerating on the current ramp.
ACCEL 2	3	Motor is accelerating using the ramp #2 acceleration profile.
DECEL	3	Motor is on decel ramp.
JOG Fwd	3	Motor is jogging in the forward direction
JOG Rev	3	Motor is jogging in the reverse direction
KICKING	3	Starter is Kicking.
KICKING 2	3	Starter is Kicking using the ramp #2 acceleration profile.
RUNNING	3	The starter ramp profile is complete.
NO LINE	3	Line voltage is not present.
Phs Err	3	The starter is receiving invalid phase signals while stopped.
O/L WARN	3	Motor is at or above 90% thermal content. Motor is about to overload.
O/L LOCK	3	Thermal overload has tripped at 100% thermal content and is locked out until motor has cooled to less than 60% thermal content.
O/L TRIP	3	Motor thermal overload has tripped and is ready to be reset.
EN SAVE	3	The energy saver feature is active.
OPEN IN	3	The 120V interlock/thermal input to JC13-1 is open.
IF Lock	3	In PF control mode the starter has reached the maximum field current limit.
IF Ctrl	3	Unit is in field current control mode.
PF Ctrl	3	Unit is in power factor control mode.

REDISTART MICRO INSTRUCTION MANUAL

2. DIAGRAMS

2.1 POWER CARD LAYOUT

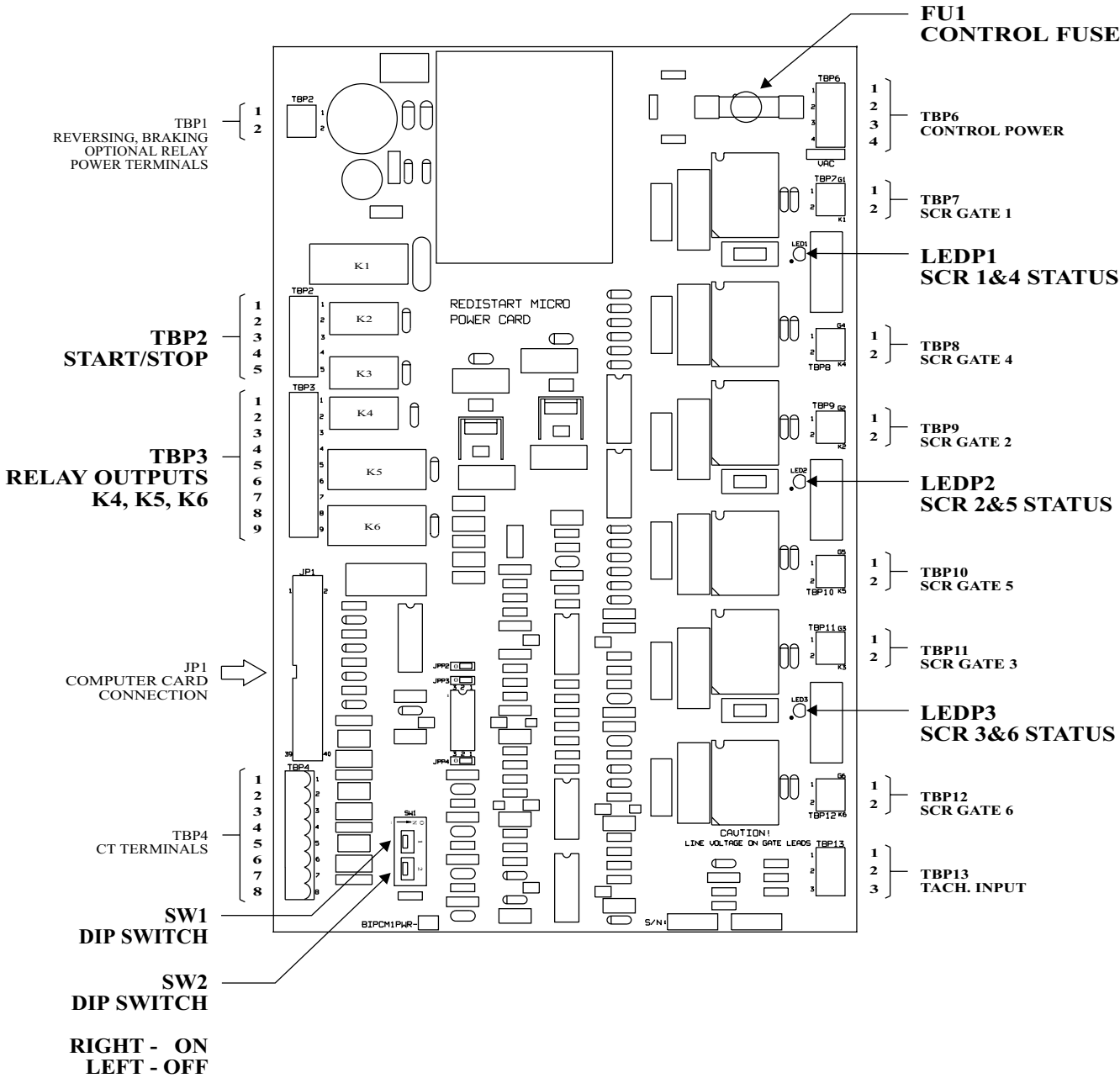

REDISTART MICRO INSTRUCTION MANUAL

2.2 COMPUTER CARD LAYOUT

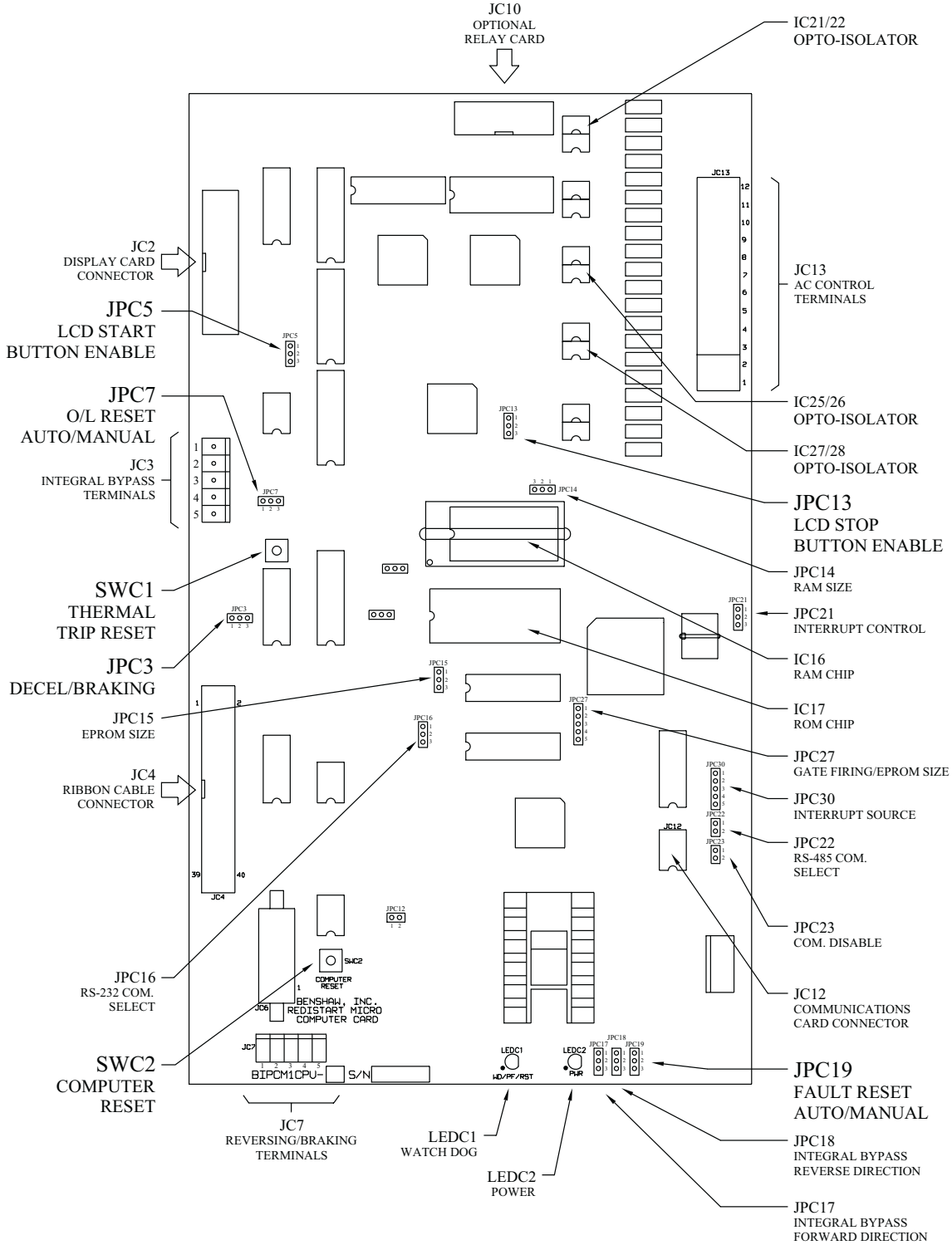

2.3 DISPLAY/KEYPAD LAYOUT

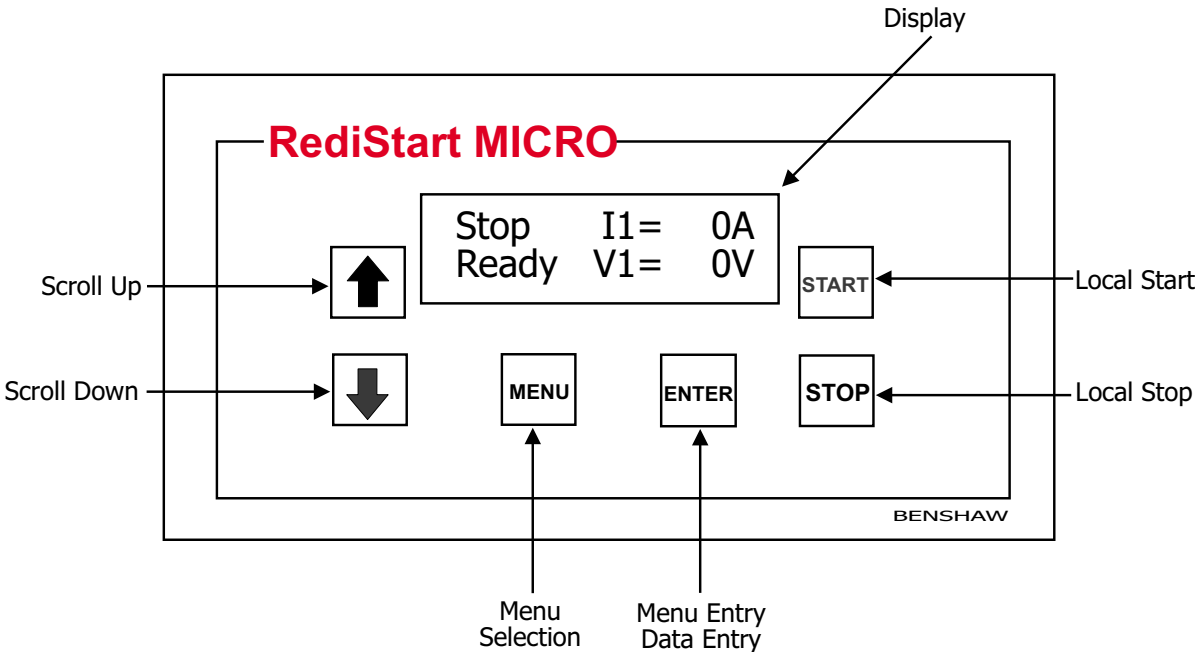

2.4 RELAY CARD LAYOUT (OPTIONAL)

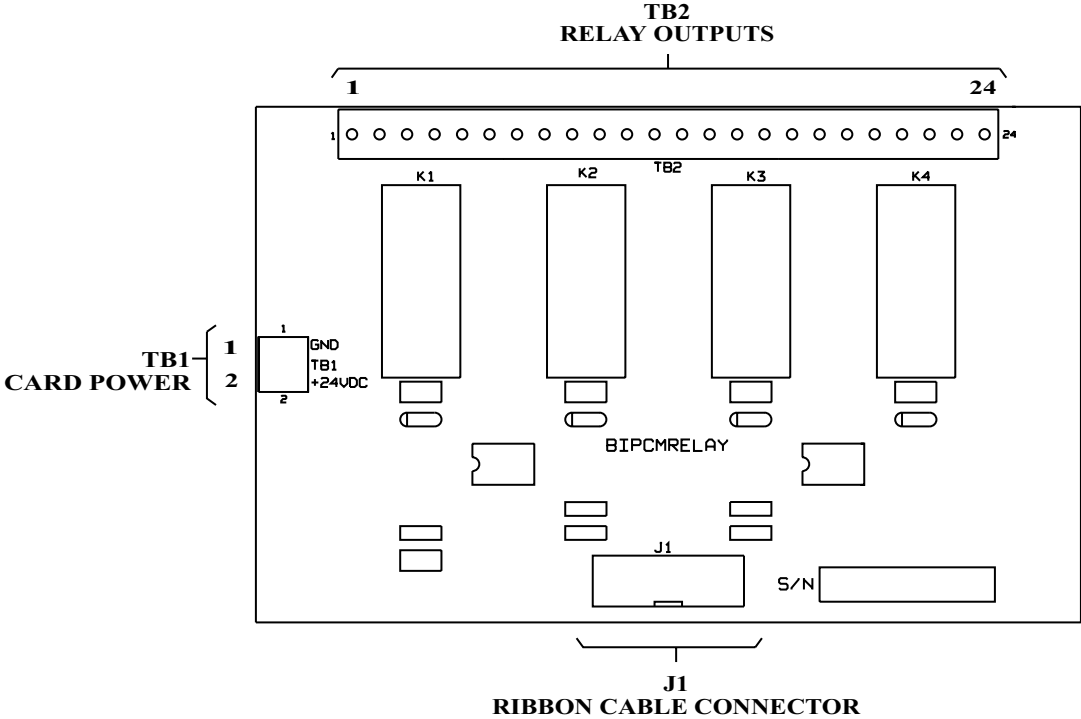

REDISTART MICRO INSTRUCTION MANUAL

2.5 WIRING DIAGRAM

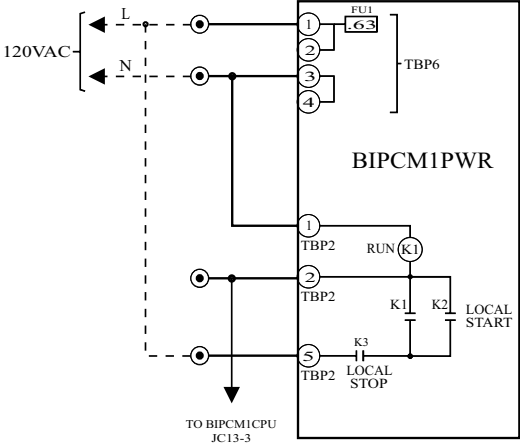

FIGURE 1: DISPLAY PAD START/STOP BUTTONS

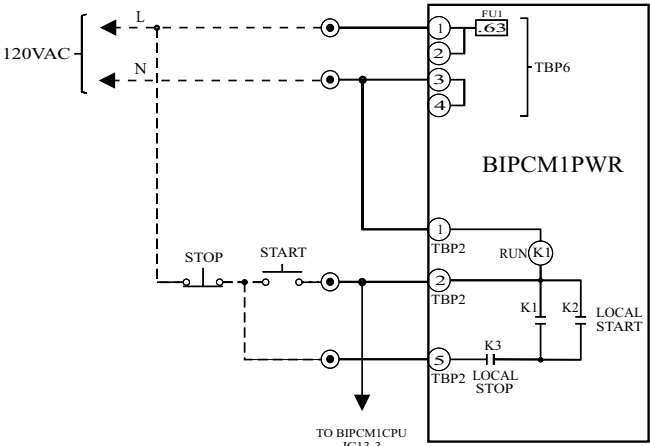

FIGURE 2: EXTERNAL START/STOP BUTTONS

NOTE: K3 SHOWN IN DE-ENERGIZED STATE.
K3 WILL ENERGIZE DURING NORMAL OPERATION
AND DE-ENERGIZE ON STOP COMMAND OR FAULT

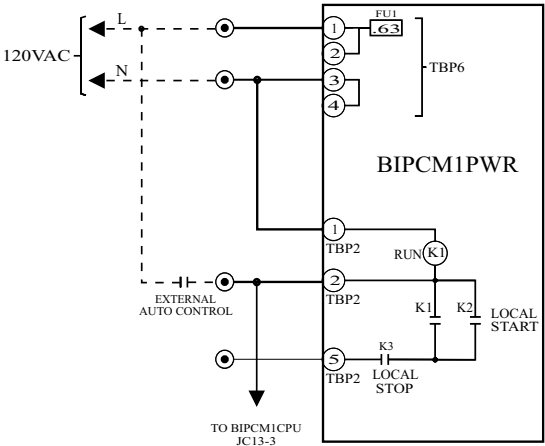

FIGURE 3: EXTERNAL AUTO CONTROL

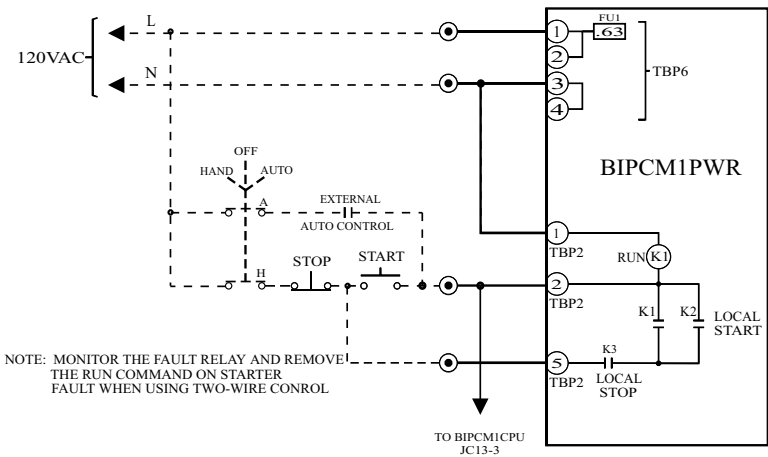
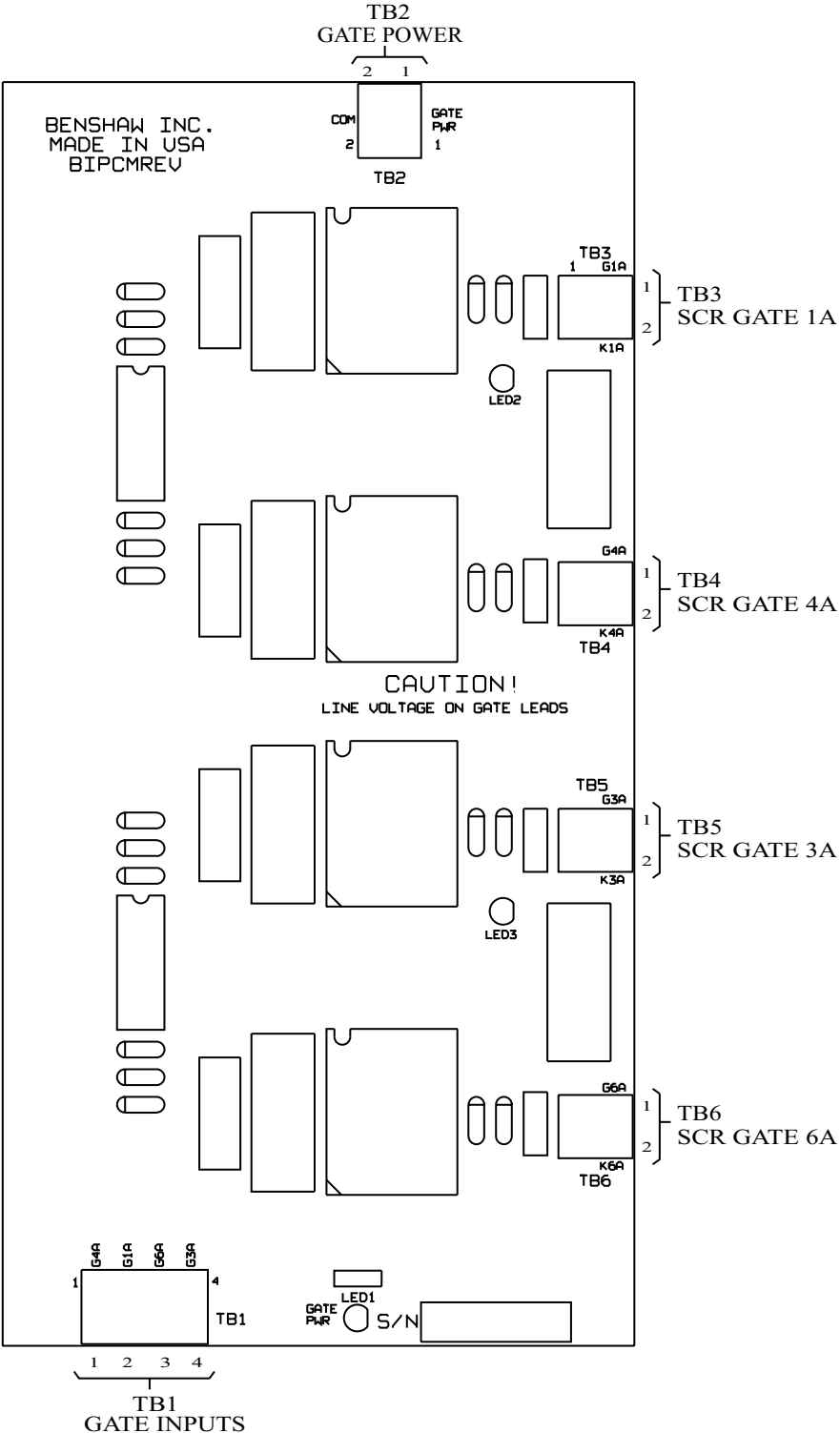

FIGURE 4: HAND/OFF/AUTO WIRING

2.6 REVERSING/BRAKING CARD DIAGRAM



REDISTART MICRO INSTRUCTION MANUAL

2.7 INTEGRAL BYPASS CARD LAYOUT

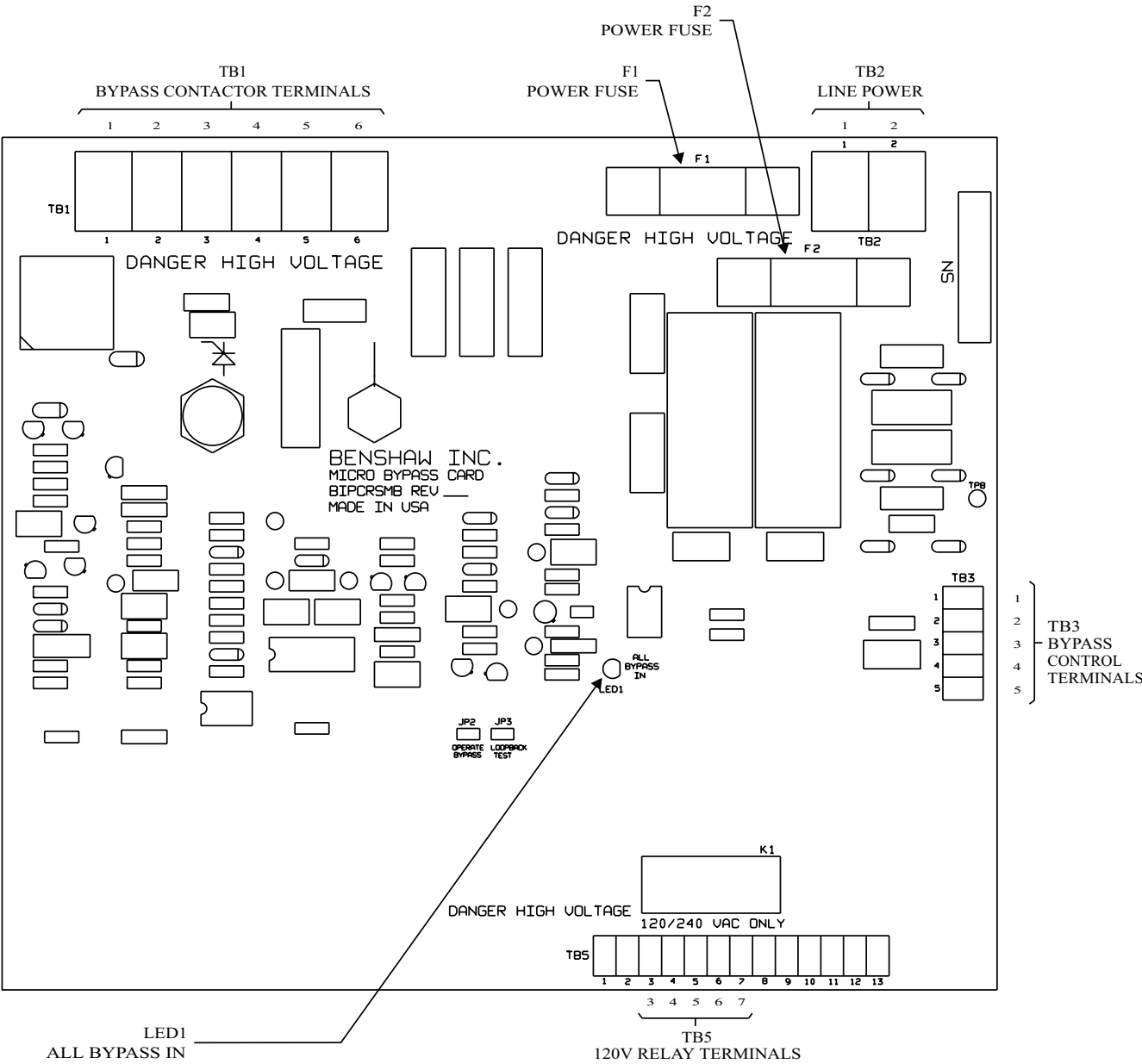

3. TECHNICAL DATA

3.1 SUPPLY VOLTAGES

- LINE POWER: Three Phase, 200 to 600V 23Hz to 72Hz
- LINE POWER: Three Phase, 2400, 3300, 4160, or 4800VAC - 23 to 72Hz
- CONTROL VOLTAGE: Single Phase, 120V (Optional 240V) - 50 to 60Hz $\pm 20\%$

3.2 CONTROL TERMINALS

3.2.1 Power Card

- TBP1-1 24VDC common for relay and reversing card power
- TBP1-2 24VDC power for relay and reversing card power
- TBP2-1 Run Relay Neutral
- TBP2-2 Run Relay Power
- TBP2-5 Run Relay Holding Contact
- TBP3-1 N.C. General Fault Contact (not faulted)
- TBP3-2 General Fault Contact Common
- TBP3-3 N.O. General Fault Contact (not faulted)
- TBP3-4 Aux Programmable Relay #1 N.O.
- TBP3-5 Aux Programmable Relay #1 Common
- TBP3-6 Aux Programmable Relay #1 N.C.
- TBP3-7 Aux Programmable Relay #2 N.O.
- TBP3-8 Aux Programmable Relay #2 Common
- TBP3-9 Aux Programmable Relay #2 N.C.
- TBP6-1&2 Control Power Live
- TBP6-3&4 Control Power Neutral

3.2.2 Computer Card

- JC13-1 External Starter Trip Input (must be energized or trip occurs)
- JC13-2 AC Neutral
- JC13-3 Run Confirm
- JC13-4 Jog Forward Select
- JC13-5 Jog Reverse Select
- JC13-6 Unused
- JC13-7 Disable Brake Input
- JC13-8 Zero Speed Switch Input
- JC13-8 Motor Winding Heater/Anti-windmilling Brake Select
- JC13-9 Ramp #2 Select
- JC13-10 External Motor Thermal Overload Reset
- JC13-11 External Computer Reset
- JC13-12 AC Neutral

3.2.3 Relay Card

- TB2-1 Optional Programmable Relay #1 N.O.
- TB2-2 Optional Programmable Relay #1 N.C.
- TB2-3 Optional Programmable Relay #1 Common
- TB2-4 Optional Programmable Relay #1 N.O.
- TB2-5 Optional Programmable Relay #1 N.C.
- TB2-6 Optional Programmable Relay #1 Common

- TB2-7 Optional Programmable Relay #2 N.O.
- TB2-8 Optional Programmable Relay #2 N.C.
- TB2-9 Optional Programmable Relay #2 Common
- TB2-10 Optional Programmable Relay #2 N.O.
- TB2-11 Optional Programmable Relay #2 N.C.
- TB2-12 Optional Programmable Relay #2 Common

- TB2-13 Optional Programmable Relay #3 N.O.
- TB2-14 Optional Programmable Relay #3 N.C.
- TB2-15 Optional Programmable Relay #3 Common
- TB2-16 Optional Programmable Relay #3 N.O.
- TB2-17 Optional Programmable Relay #3 N.C.
- TB2-18 Optional Programmable Relay #3 Common

- TB2-19 RS232/485 Communications Relay N.O.
- TB2-20 RS232/485 Communications Relay N.C.
- TB2-21 RS232/485 Communications Relay Common
- TB2-22 RS232/485 Communications Relay N.O.
- TB2-23 RS232/485 Communications Relay N.C.
- TB2-24 RS232/485 Communications Relay Common

3.3 OUTPUT CONTACT RATINGS

General Fault Relay
2A, 250VAC Resistive
1A, 250VAC Inductive
100VA max. Inrush

Power Card Relays 1 and 2
10A, 250VAC Resistive
5A, 250VAC Inductive
800VA max. Inrush

Optional Relay Card
5A, 250VAC Resistive
2A, 250VAC Inductive
400VA max. Inrush

3.4 OVERLOAD CURVES

Later in the startup procedure, you will be asked to select the class of solid state overload to be used. The following curves serve to define current versus trip times that can be expected from these different classes.

RediStart Micro Overload Curves

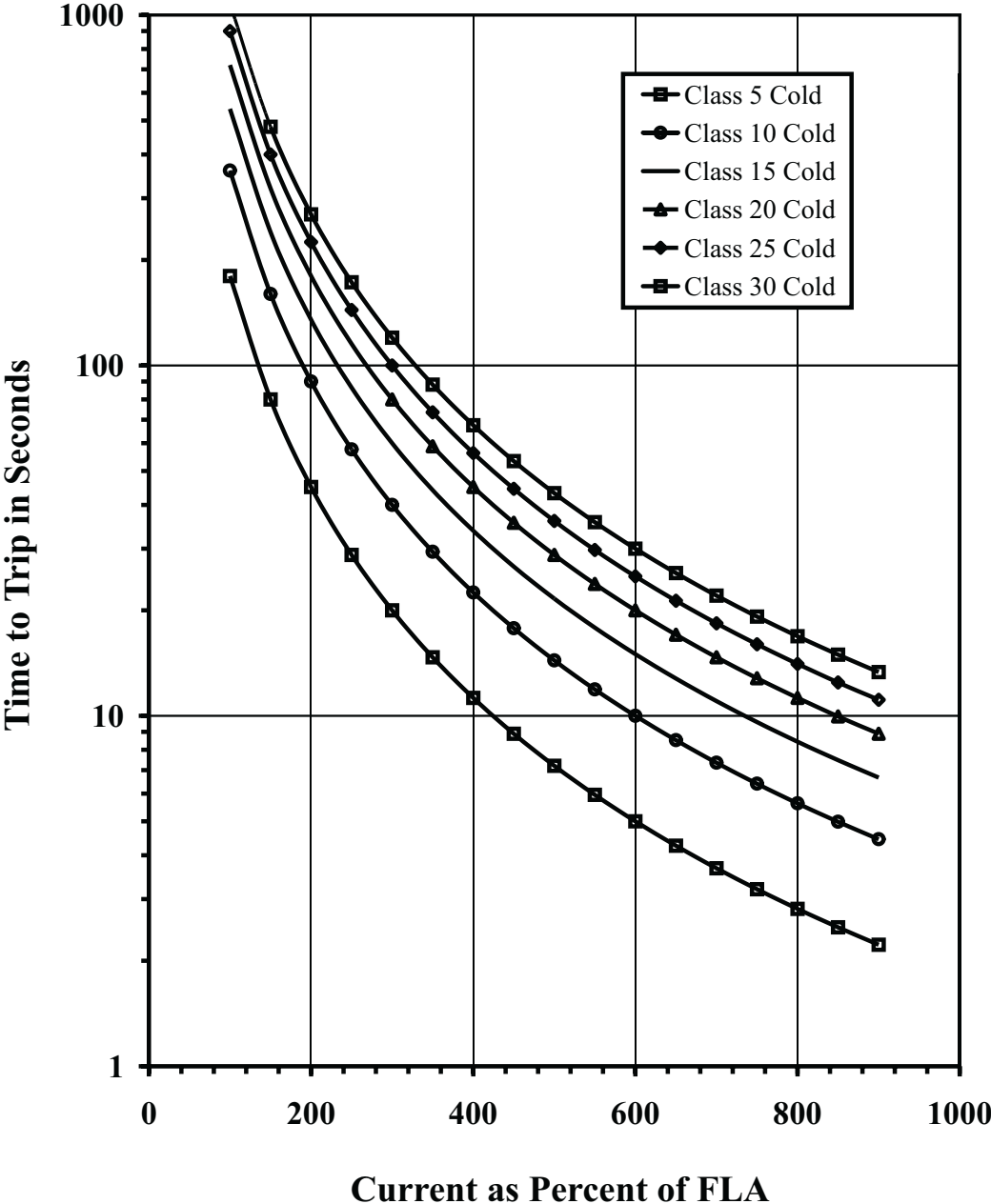

NOTE: These curves are for service factors of 1.00. For service factors of 1.15 and 1.25 the overload “Never Trip” current will shift to 1.15 and 1.25 respectively. These curves indicate trip times for “cold” starts.

4. INSTALLATION

The RediStart Micro has been packaged to protect it from damage caused by normal handling during shipment. However, mishandling may cause damage to the unit. Unpack and inspect the unit as soon as it is received and check for any shipping damage. If damage is suspected, notify the carrier immediately. Any damage reports must be filed by the customer since all shipments are F.O.B., shipping point, unless otherwise specified.

Standard NEMA 1 and NEMA 12 starters must be installed indoors in an area that is not exposed to direct water spray. Do not install in areas where the ambient temperature falls below 0°C or exceeds 40°C enclosed, or 50°C open unless this was noted at the time of order placement and special precautions were taken to protect against these abnormal temperatures.

Heatsink temperatures can run as high as 70°C during normal operation. Do not mount the starter in contact with any material which cannot accept this heat. The starter must be mounted with the heat sink fins oriented vertically in an area that will not experience excessive shock or vibration.

Ventilation Requirements

Provisions should be provided in the starter enclosure to ensure that the temperature inside the enclosure never rises above 50°C or the starter could be damaged or the life of the starter could be reduced. As a general rule of thumb the following ventilation guidelines should be followed. These values are for un-bypassed starters. Bypassed starters generally do not require ventilation.

HORSEPOWER	BOTTOM OF ENCLOSURE	TOP OF ENCLOSURE
< 200 Amps	Fan or Grill depends on enclosure size	Grills to match fans
200 - 250 Amps	1 x 4" Grill (12.5sq.in.)	1 x 4" Grill (12.5sq.in.)
251 - 300 Amps	2 x 4" Grill (12.5sq.in.)	2 x 4" Grill (12.5sq.in.)
301 - 400 Amps	1 x 4" Fan (115 CFM)	2 x 4" Grill (12.5sq.in.)
401 - 500 Amps	2 x 4" Fan (230 CFM)	2 x 4" Grill (12.5sq.in.)
501 - 600 Amps	2 x 4" Fan (230 CFM)	2 x 6" Grill (28.5sq.in.)
601 - 700 Amps	2 x 6" Fan (470 CFM)	2 x 6" Grill (28.5sq.in.)
> 701 Amps	Consult Factory	Consult Factory

4.1 SAFETY PRECAUTIONS

Electrical codes require that all equipment (starter, motor, operator station, etc.) be properly grounded. An incoming disconnect must be locked open before wiring or servicing the starter, motor, or other related equipment. The equipment must only be serviced by qualified personnel fully familiar with the equipment.

The opening of the branch circuit protective device may be an indication that a fault current has been interrupted. To reduce the risk of electrical shock, current carry parts and other components of the starter should be inspected and replaced if damaged.



Equipment is at line voltage when AC power is connected. Pressing the Stop push-button does not remove AC mains potential. All phases must be disconnected before it is safe to work on machinery or touch motor terminals and control equipment parts.

4.2 WIRING GUIDELINES

The National Electrical Code and Canadian Electrical Code requires that an approved circuit disconnecting device be installed in series with the incoming AC supply in a location readily accessible to personnel installing or servicing this equipment. If a disconnect is not supplied with the starter, one must be installed.

Supply lines and motor lines may enter the enclosure from the top, bottom or sides. Wire connections can be determined to best suit specific installations. Wire runs should be properly braced to handle both starting and fault currents. Size power cable per local electrical codes. Long lengths of cable to the motor of over 150 feet must be de-rated.

Power Factor Capacitors, Surge Capacitors and Lightning Arrestors

These devices **MUST NOT** be connected between the RediStart Micro and the motor. The SCR's in the package will be damaged by the di/dt levels created, while ramping, by these devices connected to the output of the starter. If used, power factor correction and surge capacitors must be connected ahead of the starter. Programmable relay #2 (K6) can be set to an Up-To-Speed output and then used to pull-in a contactor to connect them after full motor speed has been reached.

Electro Mechanical Brakes

If an electro-mechanical brake is used with the system, it must be powered from the line side of the starter to ensure full voltage to the brake. Programmable relay #1 (K5) can be set to a RUN output and used to control a contactor that switches the brake on when the starter is stopped.

Control Power Requirements

When the RediStart Micro is supplied as a chassis it requires a separate 120VAC source. The VA requirements of the source depend on the size and configuration of the starter. The following table gives the VA requirements for chassis starters;

STARTER CURRENT	MINIMUM VA
< 200 amps	100 VA
200 to 300 amps	200 VA
400 to 500 amps	250 VA
600 to 700 amps	400 VA
> 700 amps	Consult Factory
All Integral Bypass	100 VA

These requirements are for a stand-alone starter. Any additional 120VAC devices added in conjunction with the starter must be accounted for separately.

4.3 BEFORE APPLYING MAIN POWER

The RediStart Micro has been fully tested before leaving the factory to ensure a rapid and problem free start-up. Before applying power to the starter, consult the start-up check list below.

- Inspect starter and remove any foreign matter.
- Inspect the starter for any shipping damage.
- Ensure that all electrical connections are as per the system schematics supplied with the starter and/or connection diagrams in Chapter 3 of this manual.
- Ensure that all connections are properly tightened.
- Test L to T resistance of each phase and ensure that it is greater than 50 kohms.
- Check that the gate to cathode resistance of each SCR is between 8 and 50 ohms.
- Check the resistance of all power and motor leads to ground to ensure that there is no foreign matter present or damage to the insulation which can short one or more of the phases to ground.
- Apply 120 Vac control voltage to the RediStart Micro.
- Check that LED 2 (PWR) on the computer card is on.
- Enter system parameters into the starter using the LCD display (refer to section 5.2 - Starter Set-Up).

5. STARTER SET-UP

This chapter details the hardware and programming of the RediStart micro. These sections should be read so that the operation of the starter is fully understood.

5.1 HARDWARE SETTING

These sections detail the hardware settings for the RediStart micro. These settings control the way the starter will operate and in some cases will over-ride programmed settings.

5.1.1 Common Jumper Setting

There are seven hardware jumper settings located on the computer card that should be configured to match the application. These jumpers are identified and described below. At this time, ensure that jumper settings are set according to application requirements.

JPC3 Decel enable/disable:

Starter decel ramp control can be enabled or disabled via this jumper. If placed in position 2-3, any decel parameters programmed will be functional. If placed in position 1-2, any programmed decel parameters will not be functional. Starters are shipped from the factory with decel disabled unless defined otherwise at the time of the order.

JPC5 LCD Start Control

This jumper enables or disables the LCD **START** button. If local LCD start control is desired, this jumper should be placed in position 1-2. Otherwise, placing in position 2-3 will inhibit a start command from the LCD. The LCD Start button only functions when the starter has been wired for three wire control.

JPC7 Motor Thermal Overload Auto/Manual

The overload may be selected to reset automatically or manually after a motor overload has occurred. If automatic reset (position 1-2) is selected, the computer will reset the overload after sufficient motor cooling has occurred. If manual reset (position 2-3) is selected, then the user must reset the overload by pressing the thermal trip reset button SWC1.

JPC13 LCD Stop Control

This jumper enables or disables the LCD **STOP** button. If local LCD stop control is desired, this jumper should be placed in position 1-2. Otherwise, placing in position 2-3 will inhibit a stop command from the LCD. The LCD Stop button only functions when the starter has been wired for three wire control.

JPC17 Factory Installed Forward Bypass;

This jumper should be set to position 1-2 if the starter is supplied with a factory installed bypass contactor for the forward direction. This jumper allows the starter to monitor the contactor and ensure that it pulls-in when the starter is up-to-speed. When this jumper is installed, the starter will indicate a Fault 73-Bypass Fault if the bypass contactor fails to pull-in. The contactor feedback will be a dry contact connected between terminals 3 and 4 of JC3 on the computer card. If the starter doesn't have a bypass contactor or the feedback then this jumper should be placed in position 2-3.

JPC18 Factory Installed Reverse Bypass;

This jumper should be set to position 1-2 if the starter is supplied with a factory installed bypass contactor for the reverse direction. This jumper allows the starter to monitor the contactor and ensure that it pulls-in when the starter is up-to-speed. When this jumper is installed, the starter will indicate a Fault 73-Bypass Fault if the bypass contactor fails to pull-in. The contactor feedback will be a dry contact connected between terminals 3 and 4 of JC3 on the computer card. If the starter doesn't have a bypass contactor or the feedback then this jumper should be placed in position 2-3.

REDISTART MICRO INSTRUCTION MANUAL

JPC19 Non-Critical Fault Reset Auto/Manual

Refer to troubleshooting (see page 39) for a list of critical and non-critical faults. Critical faults always require manual reset. Non-critical faults may be selected to reset automatically or manually. If automatic reset (position 1-2) is selected, the computer will reset the non-critical fault and return to the Ready state. If manual reset (position 2-3) is selected, then the user must reset the fault by pressing the computer reset button SWC2 or by cycling the control power. If automatic reset is selected, the RediStart Micro will automatically reset four non-critical faults in one hour. After this, the starter will not reset the fault so the user should correct the problem and reset the fault manually.



When automatic O/L Reset or Automatic Fault Reset is enabled, overload and non-critical faults will be cleared automatically. When using two wire control, the fault relay must be monitored so that the run command can be removed so that the motor does not restart unexpectedly upon the O/L or fault reset.

5.1.2 Computer Card Jumpers

JUMPER	DESCRIPTION	POSITION 1-2 (In)	POSITION 2-3 (Out)	STANDARD
JPC3	Decel\Braking	Disable	Enable	1-2 2-3
JPC5	LCD Start Button	Enable	Disable	1-2
JPC7	O/L Reset Auto/Manual	Auto	Manual	2-3
JPC11	PWM Output	PWM	PLD	No Jumper
JPC12	SCR Firing	Pulse	Block	In
JPC13	LCD Stop Button	Enable	Disable	1-2
JPC14**	RAM Size	8k	2k	2-3
JPC15*	EPROM Size	27C256	27C512	2-3
JPC16	RS-232 Communications	Enable	Disable	Out
JPC17	Equip Forward Bypass	Yes	No	1-2 2-3
JPC18	Equip Reverse Bypass	Yes	No	1-2 2-3
JPC19	Fault Reset Auto/Manual	Auto	Manual	2-3
JPC21**	Non-maskable Interrupt Control	Disable	Enable	1-2
JPC22	RS-485 Communications	Enable	Disable	Out
JPC23	Serial Communications	Disable	Enable	In
JPC27**	Gate Firing Enable	--	--	No Jumper
JPC27**	EEPROM Size	512k (Pos. 4-5 In)	1024k (Pos. 4-5 Out)	In
JPC30**	Interrupt Source	Standard External Interrupt	Alternate External Interrupt	1-2

* = Jumper available on BIPCM1CPU-A4 CPU card only.

** = Jumper available on BIPC-300010-01 CPU card only.

5.1.3 CPU 16 Pin Header Assignment (JC11)

POSITION	ASSIGNMENT
1-16	Enables Reversing unused
2-15	Enables Braking
3-14	Enables RS485 Communications
4-13	Enables Motor Winding Heater/Anti-windmilling Brake
5-12	Enables Modbus Communications
6-11	Enables Emergency Reset
7-10	Enables Light Duty Braking
8-9	Not Connected

5.1.4 CT Burden Select

A DIP switch located on the power card (see power card layout on page) permits current transformer ratio scaling according to motor full load current. This switch will be factory set but can be adjusted by following this table.

MOTOR FLA	CT RATIO	Sw 1	Sw 2
3 - 9 Amps	288:1	OFF	OFF
10 - 24 Amps	288:1	ON	OFF
25 - 60 Amps	288:1	ON	ON
20 - 24 Amps	864:1	OFF	OFF
25 - 70 Amps	864:1	ON	OFF
71 - 180 Amps	864:1	ON	ON
40 - 80 Amps	2640:1	OFF	OFF
81 - 200 Amps	2640:1	ON	OFF
201 - 500 Amps	2640:1	ON	ON
70 - 160 Amps	5760:1	OFF	OFF
161 - 400 Amps	5760:1	ON	OFF
401 - 1200 Amps	5760:1	ON	ON



This DIP switch should never be adjusted when the motor is running. Otherwise, the switch may be damaged.

5.2 PROGRAMMING THE REDISTART MICRO

The RediStart Micro must be programmed before it can properly control your application. Programming is a simple procedure achieved by setting the operational parameters using the LCD Display. When control power is applied to the RediStart Micro, the LCD will briefly display a screen similar to that shown below. If the Up arrow key is held, when the starter is reset, the display will indicate the part number of the software. The starter then has to be reset again to be operational.

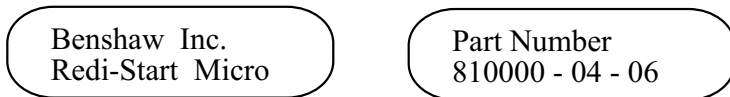

After a few seconds, the display will change to the main display which should be similar to the following.

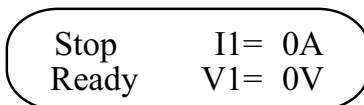

5.2.1 Function Of Display Buttons:

BUTTON	FUNCTION
--------	----------

Press to select the desired menu.

Press to exit the menu and return to the main display once programming is complete.



Press to enter a menu that has been selected with the MENU button.
Press to change the parameter presently displayed on the screen (the value will then appear on the right).
Press to store the new value entered (the “new” value on the right will replace the “Ram” value on the left)

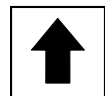

Scroll between parameters in a specific menu.
Increase a parameter value.



Scroll between parameters in a specific menu.
Decrease a parameter value.



Press to start the motor when the starter is connected for local display control.
If 2-wire control is used, or the Start button jumper is set to disable, this button is inoperative.



Press to stop the motor when the starter is connected for local display control.
If 2-wire control is used, or the Stop button jumper is set to disable, this button becomes inoperative.

NOTES:

- MENU 5 can only be viewed.
- Parameter values may be changed when the motor is stopped or when the motor is running.
- Holding an arrow key will progressively increase the rate of change. The value will stop changing when either the factory set minimum or maximum is approached. The key must then be released and repressed to make final adjustments.
- When the correct value has been selected, press the ENTER key to store the new value. If this is not done the value will remain unchanged.

REDISTART MICRO INSTRUCTION MANUAL

5.2.2 Parameter List

MENU	Parameter	Values	Default	Programmed
Menu 1: Motor Data	Motor FLA	1 to 1200 amps	1A	_____
	Service Factor	1.00, 1.15, 1.25	1.15	_____
	Jog Current	50 to 250%	200%	_____
	Jog Fwd Speed	7%, 14%	14%	_____
	Jog Rev Speed	7%, 14%	14%	_____
	Voltage Source	Auto, 100 to 1000 volts	Auto	_____
Menu 2: Starter Set-up	Fwd Init Current	50% to 400%	100%	_____
	Fwd Max Current	200% to 600%	600%	_____
	Fwd Ramp Time	0 to 120 sec.	15 sec.	_____
	Inline Contactor	No, Yes	No	_____
	CT Ratio	100, 288, 720, 864, 1000, 2640 2880, 3900, 5000, 5760	288	_____
	Decel Level 1	30 to 100%	50%	_____
	Decel Level 2	10 to 50%	20%	_____
	Decel Time	0 to 60 sec.	0 sec.	_____
	Fwd Kick Current	300% to 600%	300%	_____
	Fwd Kick Time	Off, 0.0 to 10.0 sec.	Off	_____
	2 Init Curr	50 to 400%	100%	_____
	Fwd 2 Max. Curr	200 to 400%	600%	_____
	Fwd 2 Time	0 to 120 sec.	15 sec.	_____
	Fwd 2 Kick Curr	300 to 600%	300%	_____
	Fwd 2 Kick Time	Off, 0.0 to 10.0 sec.	Off	_____
	Energy Saver	Off, On	Off	_____
	Brake Torque	0 to 100%	25%	_____
	Brake Time	0 to 30 sec.	0 sec.	_____
	Brake 2 Torque	0 to 100%	25%	_____
	Brake 2 Time	0 to 30 sec.	0 sec.	_____
Heater Current	10 to 100%	25%	_____	
MENU 3: Motor Protection	Current Imbalance	10 to 40%	20%	_____
	Line Phasing	Ins, ABC, CBA	Ins	_____
	Overload Class	5, 10, 15, 20, 25, 30, BYP, NA	10	_____
	Over/Under Voltage	10 to 30%	20%	_____
	Shear Pin Current	50 to 800%, Off	Off	_____
	Under Current	Off, 10 to 100%	Off	_____
	Ground Fault Curr	Off, 1 to 100 amps	Off	_____
	High Freq Trip	72 to 24hz	72hz	_____
	Low Freq Trip	23 to 71hz	23hz	_____
	Starts per Hour	Off, 1 to 20 starts	5 starts	_____
	Start Interval	Off, 1 to 99min.	Off	_____
Back Spin Timer	Off, 1 to 200min.	Off	_____	
Menu 4: I/O and Display	Meter#1 Display	See detailed description	Asc	_____
	Meter#2 Display	See detailed description	Vsc	_____

REDISTART MICRO INSTRUCTION MANUAL

Relay#1 Output	See detailed description	RUN	_____
Relay#2 Output	See detailed description	UTS	_____
Opt Relay#1 Out	See detailed description	UTS	_____
Opt Relay#2 Out	See detailed description	RUN	_____
Opt Relay#3 Out	See detailed description	SCR	_____
Reset WH Meter	Yes, No	No	_____

MENU 5: Stores last 99 events
Event Recorder

Menu 6: PASSCODE 000 to 999, excluding 500 000 _____
PASSCODE

Menu 7: Minutes 0 to 60m
Set Clock Hour 0 to 24h
Date 0 to 31d
Month 0 to 12m
Years 00 to 99y

Menu 8: Phase Order 0.01 to 9.00 sec. 0.07 sec. _____
Fault Delays High/Low Freq 0.1 to 180.0 sec. 0.1 sec. _____
High/Low Line 0.1 to 90.0 sec. 0.5 sec. _____
Current Imbal 0.1 to 90.0 sec. 0.5 sec. _____
Current at Stopd 0.1 to 10.0 sec. 1.5 sec. _____
No Current at RN 0.1 to 90.0 sec. 1.0 sec. _____
Ground Fault 0.1 to 90.0 sec. 1.0 sec. _____
Stall Time 0 to 210 sec. Open Loop 15 sec. _____
0 to 15 sec. Closed Loop, Off Open Loop _____
Thermal Fault 0.1 to 90.0 sec. 0.5 sec. _____
Shear Pin Fault 0.1 to 90.0 sec. 0.1 sec. _____
Under Curr Fault 0.1 to 90.0 sec. 0.1 sec. _____
Shorted SCR ramp 0.1 to 90.0 sec. 0.2 sec. _____
Shorted SCR stop 0.1 to 90.0 sec. 1.0 sec. _____
No Mains Power 1 to 5 sec. 1 sec. _____

5.2.3 Detailed description of parameters

MENU 1: Motor Data

Motor FLA	This parameter must be set to the nameplate full load current rating of the motor. This is important since all starter operations are based on this value. For multiple motors running on one starter, this parameter should be set to the sum of all motor nameplate full load currents. Valid settings are from 1A through 1200A.
Service Factor	This parameter should be set to the operating service factor of the motor. Valid settings are 1.00, 1.15, and 1.25.
Jog Current	This parameter sets the maximum current supplied to the motor while the starter is in Jog mode. This current is adjustable from 50% to 250% of the motor FLA. It should be set to the lowest possible current, that still allows the motor to maintain rotation, to avoid overheating the motor.
Jog Fwd Speed	This sets the motor speed for the jog at set speed when the fwd jog and forward direction are selected. The speed can be set to either 7% or 14% of the motor's full speed.
Voltage Source	This sets the voltage that is used for the over/under voltage trip. When set to Auto the starter uses the voltage selection chart listed under the over/under voltage trip parameter. If this parameter is set to a number then the starter will use that value as the base voltage for the over/under voltage trip calculations.

MENU 2: Starter Set-up

Fwd Init Current Fwd 2 Init Current	The initial current is adjustable from 50-400% and sets the starting point for the closed loop current ramp. The initial current is set as a percentage of the motor FLA. Ideally, this parameter should be set so that the motor develops just enough torque, at start, to rotate the load. Typical settings are from 50 - 150%. The ramp2 initial current setting controls the starter when ramp #2 is selected via input JC13-9.
Fwd Max Current Fwd 2 Max Curr	<p>The maximum current is adjustable from 200-600% and sets the endpoint for the current ramp. The max. current is also set as a percentage of motor FLA. The ramp#2 max. curr setting controls the starter when ramp #2 is selected via input JC13-9.</p> <p>Under normal conditions, this parameter should be set to 600% allowing the starter to provide more than enough current to the motor to accelerate it to full speed. This does not mean that the current, during startup, will reach this maximum setting. The maximum current will only be reached if it is required to start the load.</p> <p>For constant current applications this value may be reduced to limit the motor's maximum starting current. This set-up is typically used where weak power systems dictate a lower peak starting current value than would be achieved by using 600% as the maximum current.</p> <p>It must be noted that the maximum current must always be set high enough to allow motor acceleration to full speed under all load conditions. Monitor motor speed during startup to ensure that motor full speed is achieved with the maximum current that you have set under this parameter.</p>

REDISTART MICRO INSTRUCTION MANUAL

Fwd Ramp Time Fwd 2 Time	<p>This parameter is adjustable from 0-120 seconds and sets the time, in seconds, to smoothly ramp from the initial current to the maximum current value. Typical settings are in the range of 20-30 seconds.</p> <p>During startup, the motor may achieve full speed before the controller has ramped to the maximum set current value. This is normal for many applications. It simply means that the motor and driven load did not require the set maximum current nor ramp time to reach full speed. If motor acceleration was acceptable during startup, no further adjustments will need to be made. If the ramp time is set to 0 seconds and the maximum current is set to 600%, the starter will act as a solid state contactor with an across-the-line start.</p> <p>The actual maximum currents achieved during motor starting are a function of both the selected ramp time and the inertia of the load on the motor during startup. Extending the ramp time typically serves to reduce the peak starting current experienced during motor starting.</p>
Inline Contactor	<p>When set to yes, the RediStart Micro will properly sequence the operation of an in line contactor. This allows the starter to pull-in the inline contactor before it checks for line voltage so that it won't give a no-mains fault.</p> <p>NOTE: The coil of the inline contactor must be controlled by utilizing Programmable Relay #1 (K5) set to RUN.</p>
CT Ratio	<p>This parameter calibrates the controller to the current transformer ratio. The ratio will be factory set and will only need to be adjusted if the CT's are changed. The parameter can be confirmed by reading the ratio printed on the current transformers. Because the RediStart Micro uses high precision CT's, only CT values listed in this menu may be used.</p>
Decel Level 1	<p>Decel Level 1 sets the starting point for the decel ramp when using the open loop voltage decel. This parameter is set as a percentage of system voltage and is adjustable from 30-100%. For pump applications, a typical setting is between 35% and 40%.</p>
Decel Level 2	<p>Decel Level 2 sets the ending point for the decel ramp when using the open loop voltage decel. This parameter is set as a percentage of system voltage and must be set lower than Decel Level 1. It is adjustable from 10% to 50%. For pump applications, a typical setting is 10%.</p>
Decel Time	<p>The Decel Time sets the time the starter takes to ramp from the decel level 1 setting to the decel level 2 setting and is adjustable from 0-60 seconds. When set to 0 seconds, the decel feature is disabled. For pump applications, a typical setting is 20 to 30 seconds.</p>
Fwd Kick Current Fwd 2 Kick Curr	<p>The kick current sets the current provided to the motor during the set kick time. The kick current setting overrides the programmed current ramp profile for the kick time when a start is commanded. This setting is adjustable from 300% to 600% of motor FLA. The ramp 2 kick curr setting controls the starter when ramp #2 is selected via input JC13-9.</p>
Fwd Kick Time Fwd 2 Kick Time	<p>The kick time sets the length of time that the kick current is provided to the motor. The kick time can be set to off or from 0.1 to 10.0 seconds in 0.1 second intervals. Once the kick time has expired, the starter will revert back to the set current ramp profile. The ramp#2 kick time setting controls the starter when ramp #2 is selected via input JC13-9.</p>
Energy Saver	<p>This allows the energy saver to be either enabled or disabled. When the energy saver is enabled the starter will automatically regulate the output voltage to the motor during light load conditions to lower the power consumption of the motor.</p> <p>NOTE: The energy saver is not available when the starter is set-up for use with a factory installed bypass contactor. The parameter is still available in the menu but it can not be changed from No.</p>

REDISTART MICRO INSTRUCTION MANUAL

Brake Torque Brake 2 Torque	This sets the level of the DC brake current that reaches the motor when a brake time has been set. It is adjustable from 10 to 100%. The brake 2 torque sets the DC brake level when the ramp #2 is selected via input JC13-9.
Brake Time Brake 2 Time	This sets the time that the DC braking current is applied to the motor when a stop is commanded. It is adjustable from 0 to 30 seconds. When set to 0 the DC brake is disabled. The brake 2 time sets the DC brake time when ramp #2 is selected via input JC13-9.
Heater Current	The heater current parameter sets the amount of current that reaches the motor while the motor winding heater/anti-windmilling control is active. It is adjustable from 10 to 100%. The DC current is activated by applying 120Vac to the JC13-8 input and then giving the starter a run command.

MENU 3: Motor Protection

- Current Imbalance** This parameter sets the line to average current imbalance trip point. If the current in any one phase varies from the average current by more than this percentage, a fault is registered and the motor is shut down. This parameter is adjustable from 10% to 40%.
- Line Phasing** Line phasing can be set three ways: insensitive (INS), ABC, or CBA. If the incoming line phasing is detected to be out of sequence, a fault is registered and the lines must be transposed. This can be used to ensure that rotation sensitive equipment cannot be started if a change in the phasing of the incoming power occurs.
- Overload Class** This parameter sets the I²T electronic motor thermal overload class. Valid settings are Class 5, 10, 15, 20, 25, 30, NA, or BYP.
- The class 5 to 30 settings are the trip time, in seconds, with a motor current of 6 times the FLA. For example, a class 15 overload will trip in 15 seconds at 6 times motor FLA. Typically, the overload will be set to class 10, 15, or 20 depending on the motor and load.
- The NA setting disables the electronic motor thermal overload. This can be used in applications where another motor protection device is being used.
- The BYP setting disables the motor thermal overload during starting and then sets it to 90% of motor thermal content once the motor has reached full speed. The starter will then use a class 10 overload while it is running. This should not be used unless the system is examined to ensure that damage to the motor, while starting, will not occur. The Stall Time timer should be set to ensure motor protection when this setting is used.
- Over/Under Voltage** This parameter sets the over/under voltage trip points for the starter. If the actual line voltage on any phase varies above or below the base line voltage by more than this percentage, a fault is recorded and the motor is shut down. This parameter is adjustable from 10-30%. The base line voltage is either the value set in Menu 1 - Voltage Source or it is chosen as follows;
- 208V if average line voltage is between 180V and 224V
 - 240V if average line voltage is between 225V and 269V
 - 315V if average line voltage is between 270V and 344V
 - 380V if average line voltage is between 345V and 409V
 - 460V if average line voltage is between 410V and 489V
 - 480V if average line voltage is between 490V and 524V
 - 575V if average line voltage is between 525V and 650V
 - 1000V if average line voltage is between 651V and 1000V
- Shear Pin Current** The shear pin current sets a high current trip point which comes into effect once the starter is Up-to-Speed. It is adjustable from 50% to 800% of motor FLA. When the shear pin current value is reached the starter can be set to either activate a relay (program a relay to SPT), or shut down the starter and register a Fault 78 - Shear Pin Trip. Increasing the value above 800% will turn this feature off.
- Under Current** The under current sets a low current trip point which comes into effect once the starter is Up-to-Speed. It is adjustable from 10% to 100% of motor FLA. When the motor current falls below the set level the starter can be set to either activate a relay (program a relay to UCT), or shut down the starter and register a Fault 79 - Under Current. Decreasing the value below 10% will turn this feature off.

REDISTART MICRO INSTRUCTION MANUAL

Ground Fault Curr	The ground fault curr sets the ground fault level for motor protection. The starter uses the residual machine ground fault method. The ground fault level is adjustable from 1 to 100 amps. When a ground fault trip occurs the starter can be set to either activate a relay (program a relay to GDF), or shut down the starter and register a Fault 71 - Ground Fault. If the value is set below 1 amp then Off will appear and the ground fault protection will be disabled. A typical setting for the ground fault is between 10% and 20% of motor FLA.
High Freq Trip	The high freq trip sets the highest frequency that the starter will operate at. It is adjustable from 72 to 24 Hz in 1Hz intervals. If the frequency goes above this value, the starter will shut down and register a Fault 4 - Frequency > High.
Low Freq Trip	The low freq trip sets the lowest frequency that the starter will operate at. It is adjustable from 23 to 71 Hz in 1Hz intervals. If the frequency goes below this value, the starter will shut down and register a Fault 5 - Frequency < Low.
Starts per Hour	The starts per hour sets the number of starts allowed each hour. It is adjustable from 1 to 20 starts in 1 start intervals. Decreasing the value below 1 start will turn this feature Off. If the number of starts per hour is exceeded, the starter will display SPH in the top left of the display and the time, in minutes, before the next start in the bottom left of the display.
Start Interval	The start interval sets the minimum allowed time between starts. It is adjustable from 1 to 99 minutes in 1 minute intervals. Decreasing the value below 1 minute will turn this feature off. If the start interval is exceeded, the starter will display TBS in the top left of the display and the time, in minutes, before the next start in the bottom left of the display.
Backspin Timer	The backspin timer sets the minimum allowed time between a stop and the next start.. It is adjustable from 1 to 200 minutes in 1 minute intervals. Decreasing the value below 1 minute will turn this feature off. If the backspin timer is active, the starter will display BST in the top left of the display and the time, in minutes, before the next start in the bottom left of the display.

MENU 4: IO & Display

Meter #1 Display

Meter #2 Display

Each display meter may each be programmed to display one of the following;

- Aavg - Average current going through the starter.
- Asc - Current in a scrolling format so all phase currents can be viewed.
- A1 - Current going through phase 1.
- A2 - Current going through phase 2.
- A3 - Current going through phase 3.
- Vavg - Average voltage being applied to the starter.
- Vsc - Voltage in a scrolling format so all phase voltages can be viewed.
- V1 - Voltage applied to phase 1.
- V2 - Voltage applied to phase 2.
- V3 - Voltage applied to phase 3.
- Hz - frequency.
- OL - motor overload content.
- pf - power factor.
- etm - elapsed time meter.
- W - watts.
- WH - watt-hours.
- VAR - volt-amps reactive.

Relay #1 Output

Relay #2 Output

Auxiliary relays 1 and 2 may be programmed to change state for one of the following conditions;

- OL - overload trip.
- OLL - overload lock.
- OLW - overload warning.
- RUN - starter operating.
- UTS - motor up-to-speed.
- SCR - shorted SCR.
- SHT - shunt trip output.
- GDF - ground fault.
- SPT - shearpin trip.
- UCT - under current trip.

The OLW contact can be used to drive a motor unloader, the RUN contact can be used to sequence an inline contactor, and the UTS contact can be used to sequence a bypass contactor. The factory default setting for Relay #1 is RUN so this relay should always be used for any operation requiring an RUN contact. The default for Relay #2 is UTS so this relay should always be used for any operation requiring an UTS contact.

The shunt trip (SHT) contact will change state on various fault scenarios. If the automatic fault reset jumper (JPC19) is not in, this relay will change state on any fault. If the automatic fault reset jumper is in, this relay will change state on any critical fault or on the occurrence of the fourth non-critical fault in one hour. This relay output option is intended to be used for shunt tripping a circuit breaker or indicating a fault that can not be reset automatically.

Opt Relay #1 Out

Opt Relay #2 Out

Opt Relay #3 Out

These menu options control the operation of the three programmable relays on the optional relay card. Optional relays 1, 2, and 3 may each be programmed to any of the same functions as listed for Relay #1 Output and Relay #2 Output.

Reset WH Meter

This permits the user to reset the internal Watt-Hour meter. When set to Yes the meter is reset back to zero. This parameter will remain at No even when the Yes is entered and the Watt-Hour meter is reset

MENU 5: Event Recorder

The event recorder stores the last 99 events. See the Troubleshooting section beginning on page 39 for a description and listing of codes and conditions. A * beside the event number indicates the most recent event. Events occur in ascending order so pressing the up arrow key will show the previous event.

MENU 6: Password Protection

Enter Password

The RediStart Micro is supplied with a passcode protection feature. When this feature has been enabled, most programmable menu parameters can only be viewed and not changed. The only parameters which can be altered when the passcode is enabled are the METER #1 & METER #2 Display parameters.

The RediStart Micro is shipped with the passcode feature disabled. This is indicated by a passcode value of 000 appearing under the password menu. If passcode protection is desirable, the user may select a three digit passcode from 001 to 999 (excluding 500). This value is entered just like any other parameter.

When the passcode is chosen and entered, the starter will be in data entry enabled mode. In order to lock out data entry, the user must set the passcode to any other value or press the RediStart Micro reset button (SWC2). This action will lock out data entry and indicate passcode protect mode with a small dot (.) in the bottom center of the display. To re-enable data entry, simply re-enter the passcode. Once the data has been changed, ensure that the passcode is once again changed to a number other than the actual passcode or that the RediStart Micro reset button is pressed.

If it is desirable to change the passcode, the user must enter the old passcode, and reset the passcode back to the factory default of 000. This action will disable the passcode protection and allow for a new passcode to be set.

NOTE: Do not forget your passcode. There is no way of determining the passcode if it is forgotten. If a passcode is forgotten, it will require a new RAM memory chip installed on the computer card. These chips must be obtained from the factory.

MENU 7: Set Clock

Minutes	Enter the present minute.
Hour	Enter the present hour using 24 hour convention.
date	Enter the current day of the month.
Month	Enter the current month.
Years	Enter the current year

MENU 8: Fault Delays

Phase Order	The phase order delay sets the delay time before a phase order fault occurs. A phase order fault occurs when the starter detects a change in the phase sequence of the incoming three phase power. The phase order parameter is adjustable from 0.01 to 9.00 seconds in 0.01 second intervals. The factory setting of 0.07 seconds is fine for most applications.
High/Low Freq.	The high/low frequency delay sets the time that the frequency must be either above the high freq. trip setting or below the low freq. trip setting before the starter will fault. It is adjustable from 0.1 to 180.0 seconds in 0.1 second intervals.
High/Low Line	The high/low line delay sets the time that the line voltage must be outside of the over/under voltage setting range before a high or low line fault will occur. It is adjustable from 0.1 to 90.0 seconds in 0.1 second intervals. The default parameter of 0.5 seconds is will work for most applications but the time can be increased to allow a motor to start on a weak supply or to compensate for incoming voltage swings.
Current Imbal	The current imbalance delay sets the time that the motor currents must be out of the range set by the current imbalance parameter before the starter will give a current imbalance fault. The delay time is adjustable from 0.1 to 90.0 seconds in 0.1 second intervals. The factory default of 0.5 seconds will work for most applications unless intermittent faults occur.
Current at Stopped	The current at stopped delay sets the time that a motor current of greater than 5% of FLA must flow, while the starter is in a stopped state, before a current while stopped fault occurs. The time is adjustable from 0.1 to 10.0 seconds in 0.1 second intervals.
No Curr at RN	The no current at run delay sets the time that a motor current of less than 5% of FLA must flow, while the starter is in a run state, before a no current at run fault occurs. It is adjustable from 0.1 to 90.0 seconds in 0.1 second intervals.
Ground Fault	The ground fault delay sets the time that a ground fault current must be above the ground fault current setting before a ground fault will occur. The time is adjustable from 0.1 to 90.0 seconds in 0.1 second intervals.

REDISTART MICRO INSTRUCTION MANUAL

Stall Time	<p>The RediStart Micro will monitor the motor, during a motor start, to determine it has reached operating speed. There are two types of stalled protection. A timer function that monitors the motor current and a timer function that monitors a zero speed switch.</p> <p>When using the open loop current monitoring function, a stalled motor condition will be detected if the motor does not reach an up-to-speed condition before the ramp time plus the set stall time has expired. The motor is considered up-to-speed once the current stabilizes below 125 percent of the FLA value and the ramp time has expired. The current monitoring stall time is programmable from 0 to 210 seconds and is indicated by an O appearing after the time.</p> <p>When using the closed loop zero speed monitoring function, the starter will start monitoring the zero speed input (at JC13-8) as soon as a run command is given and will recognize a stalled motor if the set stall time has elapsed before the zero speed signal is removed. The zero speed input requires a 120VAC signal to indicate the zero speed condition. The zero speed monitoring time can be set from 0 to 15 seconds and is indicated by a C after the time.</p> <p>Fault Code 74 - Up to Speed Fault will be displayed when a stalled motor condition is detected.</p>
Thermal Fault	<p>The thermal fault delay sets the time that the 120VAC signal must be removed from the JC13-1 input on the computer card before the starter will give a thermal fault. It is adjustable from 0.1 to 90.0 seconds in 0.1 second intervals. The delay can be adjusted to suit any external trip circuitry wired into this input.</p>
Shear Pin Fault	<p>The shear pin fault delay sets the time that the current must be above the shear pin current setting in menu 3 before the starter trips. It is adjustable from 0.1 to 90.0 seconds in 0.1 second steps.</p>
Under Curr Fault	<p>The under current fault delay sets the time that the current must be below the under-current setting in menu 3 before the starter trips. It is adjustable from 0.1 to 90.0 seconds in 0.1 second steps.</p>
Shorted SCR Ramp	<p>The shorted SCR ramp delay sets the time that there must be a current imbalance greater than 50%, while the starter is ramping, before a shorted SCR fault occurs. It is adjustable from 0.1 to 90.0 seconds in 0.1 second intervals.</p>
Shorted SCR Stop	<p>The shorted SCR stop delay sets the time that a current of more than 50% of the Motor FLA must flow, while the starter is in a stopped condition, before a shorted SCR fault occurs. It is adjustable from 0.1 to 90.0 seconds in 0.1 second intervals.</p>
No Mains Power	<p>The no mains power delay sets the time that the starter must have a Run command without main power before a no mains fault occurs. It is adjustable from 1 to 5 seconds in 1 second intervals.</p>

5.3 FINE TUNING

When all the parameters are programmed, the motor may be started. It may be necessary to adjust the initial current, maximum current and/or ramp time to more properly suit specific applications.

When the start command is given, the motor should begin to rotate immediately. It should not stall. Increase the initial current setting in Menu 2 to correct an initial stall condition. Decrease the initial current if the motor begins rotating too quickly.

The ramp time can be adjusted to extend or decrease the acceleration time. To speed up the acceleration, decrease the ramp time. To extend the acceleration, increase the ramp time.

Lower the Maximum Current setting to limit the current to the desired value. If the motor doesn't accelerate properly with the set current limit, then raise the Maximum Current setting. This allows more current to flow to the motor so it can produce more torque and accelerate properly. In all cases, the setting of a current limit should be performed while the motor is under it's worst case load conditions so that a change in the load won't stall the motor.

Lower Decel Level 1 to correct an initial surging condition during decel. If the motor stops rotating before the decel time has expired, raise Decel Level 2 or shorten the decel time. If the motor is still rotating too fast when the decel time has expired, lower Decel Level 2 or extend the decel time.

Any of these fine tuning adjustments can be made without having to remove power to the starter or change any wiring. These adjustments can also be made while the starter is ramping or running.

6. TROUBLESHOOTING

The RediStart Micro includes a number of diagnostic LED on the circuit cards and a display which will give a plain English read-out of the starter status as well as the reason for any fault which causes the starter to shut-down. The following sections give details of these troubleshooting aids as well as a list of possible fault codes and general troubleshooting charts.

6.1 LED INDICATION

There are several diagnostic LEDs located on the computer and power cards. These indicators are primarily used for troubleshooting. Refer to power and computer card layouts for LED locations.

CARD	LED#	NAME	INDICATOR
Computer	LEDC2	CONTROL POWER	On when control voltage is present
Computer	LEDC1	WATCH DOG/ POWER FAIL/RESET	On during reset, if computer has failed, or the control voltage has failed.
Power	LEDP1 - 3	GATE STATUS	Indicates forward SCR condition; Stop - Lights must be on, otherwise SCR is shorted. Start - Lights will become dimmer as motor accelerates. Run - Lights must be fully off, otherwise SCR is open or misfiring.
Bypass	LED1	All Bypass In	On when all Bypass Contactors are successfully pulled in
Reversing	LED1	Gate Power	On When 120Vac is applied to starter
Reversing	LED2 - 3	Gate Status	Indicates reverse SCR condition. Same as Power Card LEDP1-3

6.2 FAULTS

If the starter detects a fault during normal operation, the motor is shut down, the fault contact changes state, the event is logged in the event recorder, and the fault code and a brief description of the fault is displayed. When JPC19 FAULT A/M is set to Manual, all faults (except motor thermal overload if set for automatic reset) must be manually reset by depressing the reset button on the computer card or by cycling the control power to the starter. When JPC19 FAULT A/M is set to Automatic, non-critical faults will automatically be reset. Refer to the Starter Set-Up section for jumper setting details. Critical power faults, shorted SCR, and instantaneous overcurrent faults will not reset automatically in any case. These faults can be destructive, and for this reason, require user inspection.

6.3 EVENT RECORDER

Each time an event occurs, the code, condition, and time of the event will be recorded in the revolving event recorder. An event is anything that changes the present state of the starter. Examples of events include an operation fault, a Start command, a Stop command, an overload warning, or an overload trip. The event recorder holds 99 events and they are entered in the recorder in sequential order from 0 to 99 and then the recorder rolls over and begins at 0 again. Each time a new event is recorded it overwrites the oldest event stored. The data in the event recorder can not be altered or erased by the user.

The event recorder may be viewed by following the steps necessary to enter MENU 5 (refer to section 5.2 - Programming the RediStart Micro). When the menu is entered the most recent event will be shown and it will be indicated by an asterisk beside the event number. Once in this menu, the last 99 events may be viewed by scrolling with the arrow keys. Pressing the Up arrow key will move through the event recorder from the newest event to the oldest event. Pressing the Down arrow key will move through the event recorder from the oldest event to the newest event. Each event in the recorder shows the code, condition, time, and date the event occurred.

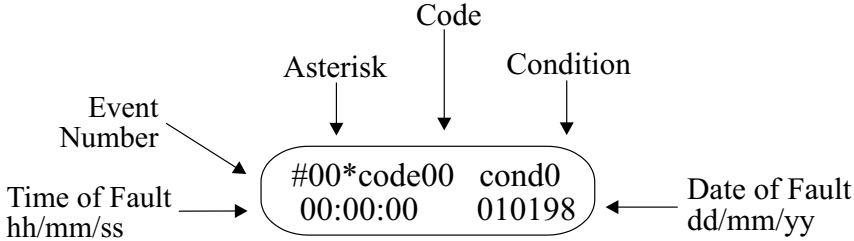

REDISTART MICRO INSTRUCTION MANUAL

6.4 CODES

CODE	CRITICAL	POSSIBLE CAUSE	CORRECTION
CODE 0		A Stop or Start was given.	Logs times of start/stop operations.
CODE 1		Line sequence was set as CBA in Menu 3 but is actually ABC.	Swap incoming lines or change setting to ABC.
CODE 2		Line sequence was set as ABC in Menu 3 but is actually CBA.	Swap incoming lines or change setting to CBA.
CODE 3		No Phase Order.	Very distorted or noisy line. Check line quality, consider a line reactor.
CODE 4		Line frequency is > High Freq. Setting.	Check line frequency.
CODE 5		Line frequency is < Low Freq. Setting.	Check line frequency.
CODE 6		100% not allowed, removed jog command.	Retain Fwd jog command while jogging.
CODE 7		100% not allowed, removed jog command.	Retain Rev jog command while jogging.
CODE 8		Invalid Jog, both Fwd and Rev requested.	Apply jog command to correct input only.
CODE 15		Line phasing error, phase sequence has changed since last start command.	Reset computer.
CODE 16	X	Extreme noise on line.	Add suppressors to control wiring.
CODE 17		Voltage on line 1 is high.	Inspect line and correct.
CODE 18		Voltage on line 2 is high.	Inspect line and correct.
CODE 19		Voltage on line 3 is high.	Inspect line and correct.
CODE 20		Voltage on line 1 is low.	Inspect line or increase voltage level.
CODE 21		Voltage on line 2 is low.	Inspect line or increase voltage level.
CODE 22		Voltage on line 3 is low.	Inspect line or increase voltage level.
CODE 23		Current on line 1 is high.	Inspect and correct or increase current imbalance level in Menu 3.
CODE 24		Current on line 2 is high.	Inspect and correct or increase current imbalance level in Menu 3.
CODE 25		Current on line 3 is high.	Inspect and correct or increase current imbalance level in Menu 3.
CODE 26		Current on line 1 is low.	Inspect and correct or increase current imbalance level in Menu 3.
CODE 27		Current on line 2 is low.	Inspect and correct or increase current imbalance level in Menu 3.
CODE 28		Current on line 3 is low.	Inspect and correct or increase current imbalance level in Menu 3.
CODE 29	X	RAM battery is new or has lost data.	While holding the down arrow key, press the computer reset button on the CPU card. Continue holding the down arrow key until fault 30 appears on the LCD.
CODE 30	X	Default parameters have been loaded from the RAM chip.	Press the computer reset button. NOTE: All menu parameters must be re-entered.
CODE 50		The LCD start or stop has failed or was held during reset.	Press the computer reset button making sure not to touch the LCD. If the fault still occurs, replace the LCD membrane.
CODE 52	X	Detected current flow while stopped.	Inspect SCR's and wiring for shorts.
CODE 53		No current flow was detected during a run state.	Verify motor leads T1, T2, T3 wiring and CT's.
CODE 70		Low control voltage.	Inspect control voltage and correct.

REDISTART MICRO INSTRUCTION MANUAL

CODE 71	X	Ground Fault.	The Ground Fault Current in menu 3 was exceeded.
CODE 72	X	Invalid CT Burden DIP switch setting.	Refer to section 5.1.4 for valid settings.
CODE 73	X	The optional by-pass contactors failed to stay closed.	Inspect and correct.
CODE 74	X	Up-to-Speed fault. The motor stalled.	Increase maximum current, ramp time, or stall time.
CODE 75	X	Thermal or external fault	Power is missing from JC13 terminal 1
CODE 76		Disconnect Open.	The main disconnect is open.
CODE 77		In-Line Fault	Check the wiring of the In-line Contactor.
CODE 78		Shear Pin Fault.	Motor current has gone over the Shear Pin Current as set in menu 3.
CODE 79		Under Current Fault.	Motor current has gone below the Under Current as set in menu 3.
CODE 80		High Field Current.	Check cabling for shorts.
CODE 81		Field Loss.	Check field windings and wiring for opens.
CODE 82		Out of Sync Fault.	Reduce motor load or increase field current.
CODE 83		High Power Factor - Field set too high.	Decrease field current.
CODE 84		Low power factor - Field set too low.	Reduce motor load or increase field current.
CODE 85		Loss of Sync flag - Field current too low or too much load.	Reduce motor load or increase field current.
CODE 86		IF control mode - Unit could not maintain PF mode.	Increase PF set point or use current control mode.
CODE 87		Incomplete sequence - Motor did not synchronize before set time elapsed.	Increase sequence time, reduce starting load, or increase slip speed detection.
CODE 89		An overload warning has occurred.	Unload the motor or shut down to allow motor cooling time.
CODE 90		A motor overload has occurred.	Once the motor has cooled restart and monitor for overload conditions.
CODE 91	X	Invalid start command received..	Consult factory if Fault persists.
CODE 92	X	Shorted SCR on line 3.	Inspect SCRs and correct.
CODE 93	X	Shorted SCR on line 2.	Inspect SCRs and correct.
CODE 94	X	Shorted SCR on line 1.	Inspect SCRs and correct.
CODE 95	X	Shorted SCR on line 2&3.	Inspect SCRs and correct.
CODE 96	X	Shorted SCR on line 1&3.	Inspect SCRs and correct.
CODE 97	X	Shorted SCR on line 1&2.	Inspect SCRs and correct.
CODE 98		No mains power. Line power was not present when start command was given.	Inspect line, inspect line contactor if present.
CODE 99	X	The output of the starter is shorted. CT Burden Select switches set wrong.	Inspect wiring and correct. Check CT Burden Select switch settings.

6.5 CONDITIONS

CONDITION	DESCRIPTION OF CONDITION
0	Starter was in a stop condition (Decel complete and no power output to motor).
1	Start command was given, starter ramp time had not expired and motor was not at full speed.
3	Start command was given, starter ramp time had expired and motor was not at full speed.
5	Start command was given, starter ramp time had not expired and motor was at full speed.
6	Stop command was given and starter went to D.C. Brake mode.
7	Start command was given, starter ramp time had expired and motor was at full speed.
8	Stop command was given and starter went to decel mode.

6.6 TROUBLESHOOTING CHARTS

6.6.1 Motor Will Not Start - No output voltage to the motor

Display	Possible Cause	Possible Solutions
Fault displayed.	See fault description.	Address fault condition.
Watchdog LED on.	CPU card problem.	Consult Factory.
Display is blank.	Control voltage is absent. FU1 on power card. Ribbon cables.	Check control wiring and correct if necessary. Replace FU1. Check cables.
Stopped.	Pilot devices. Start-Stop control has not been enabled on LCD display. Control voltage.	Check wiring. Check manual for proper jumpers to enable control capability. Check wiring. Check control voltage.
No line.	Missing at least one phase of line power	Check power system.

6.6.2 Motor Rotates (but does not accelerate to full speed)

Display	Possible Cause	Possible Solutions
Fault displayed.	See fault description.	Address fault condition.
Accel or Running.	Mechanical problems. Inadequate current limit setting. Improper parameter settings.	Check for binding of external load and correct. Check motor. Adjust the Current Limit Level to a higher setting. Check parameters and correct.

6.6.3 Decel Not Operating Correctly

Problem	Possible Cause	Possible Solutions
Display shows Decel but motor coasts to a stop.	Improper jumper setting.	Check jumper JPC3.
Motor stops too quickly with soft stop (Decel) option.	Time setting. Improper level setting.	Increase the decel time. Increase decel level 1 and/or decel level 2 settings.
Note: The Decel Option is intended to extend the stopping time for loads that stop suddenly when power is removed from the motor.		
Decel time seems appropriate but motor surges at the start of decel cycle.	Decel level 1.	Voltage being applied to motor too high. Decrease Level 1 by 5% and continue to decrease by 5% until surge is eliminated.
Decel time seems appropriate but motor comes to a stop before decel cycle is complete.	Decel level 2.	Load on motor is great enough to stop motor before decel ramp is complete. Increase decel level 2 to complete Decel profile at same time motor stops.
Decel time seems appropriate but water hammering continues when decel is complete.	Decel level 2.	Decrease decel level 2 by 5% until water hammer is eliminated.

6.6.4 Motor Stops While Running

Display	Possible Cause	Possible Solutions
Fault displayed.	See fault description.	Address fault condition.
Display is blank.	Control Voltage is absent FU1 on power card.	Check control wiring and correct if necessary. Replace fuse.
Stopped 0A.	Control devices.	Check control system and correct if necessary.

REDISTART MICRO INSTRUCTION MANUAL

6.6.5 Miscellaneous Situations

Problem	Possible Cause	Possible Solutions
Motor current and voltage fluctuates with steady load.	Motor. Energy Saver Connection problem. SCR fault Erratic load.	Verify type of motor as a standard squirrel cage induction motor. Set Energy Saver Off, then restart Shut off all power to starter and check connections. Check voltage drop across SCR's. If voltage drop is <1.5V then starter is working properly Check load conditions.
Erratic Operation.	Loose connections.	Check for loose connections.
Accelerates too fast.	Ramp time. Initial current. Current limit setting. Kickstart . Improper FLA setting.	Increase ramp time. Decrease initial current setting. Decrease current limit setting. Lower kickstart time or turn off. Compare programmed FLA to motor name plate.
Accelerates too slowly.	Ramp time. Initial current. Maximum current setting. Kickstart. FLA not programmed in properly.	Decrease ramp time. Increase initial current setting. Increase maximum current setting. Increase kickstart current or time. Compare programmed FLA to motor name plate.
Motor overheats.	Duty cycle. High ambient. Too long acceleration time. Wrong overload setting. Too long jog cycle 7&14%	Allow for motor cooling between Start/Stop cycles. Provide better ventilation. Reduce motor load. Correct overload setting. Extended operations at slow speeds increases current and reduces motor cooling efficiency. Consult motor manufacturer for motor limitations.
Motor short circuit. (Fault code 99)	Wiring fault. Power factor capacitors on output of starter.	Identify fault and correct. Ensure power terminals are secure. Remove power factor capacitors or reconnect to line side.
Fans do not operate on 156-1200A starters.	Wiring. Failed fan(s). Fuse blown.	Check wiring and correct if necessary. Replace fan(s). Check fuses and replace if necessary.
Display buttons do not work.	Display ribbon cable. Display faulty.	Check faceplate cable on back of display. Replace display.

7. SPARE PARTS

PART NUMBER	DESCRIPTION	QUANTITY
BIPCM1CPU - A4	Micro computer card	1
BIPCM1PWR - A4	Micro power card	1
BIPCRSMB	Micro bypass card	1 - optional
BIPCM1REV	Micro reversing card	1 or 2 - optional
BIPCM1LCD	Micro LCD display	1
BIPCMRELAY	Micro Relay Card	1 - optional
BIPCMCOMS (232)	Micro 232 communications card	1 - optional
BIPCMCOMS (485)	Micro 485communications card	1 - optional
RI-101A	LCD ribbon cable (specify length)	1
RI-101B	Computer/power card ribbon cable.	1
BI-M-FU1	Micro Power Card Fuse	1
BISCR5012X	SCRs used on 1-28 Amp starters	3
BISCR7012X	SCRs used on 29-42 Amp starters	3
BISCR10012X	SCRs used on 43-54 Amp starters	3
BISCR13212X	SCRs used on 55-68 Amp starters	3
BISCR16112X	SCRs used on 69-80 Amp starters	3
BISCR21012X	SCRs used on 81-130 Amp starters	3
BISCR25012X	SCRs used on 131-156 Amp starters	3
BISCR6601218	SCRs used on 157-248 Amp starters	3
BISCR8801230	SCRs used on 249-384 Amp starters	6
BISCR15001850	SCRs used on 385-840 Amp starters	6
BISCR220012100	SCRs used on 841-1200 Amp starters	6
SIOV	Voltage transient protector	3
BIPCDVDT-1L	1 line DV/DT snubber network	3 - optional
BIPCDVDT-3L	3 line DV/DT snubber network	1 - optional
BICT2881M	Current transformers 3-50 Amp starters (see schematic)	3
BICT8641M	Current transformers 51-157 Amp starters (see schematic)	3
BICT26401M	Current transformers 158-400 Amp starters (see schematic)	3
BICT57601M	Current transformers 400-1200Amp starters (see schematic)	3

8. DISPLAY CUT-OUT

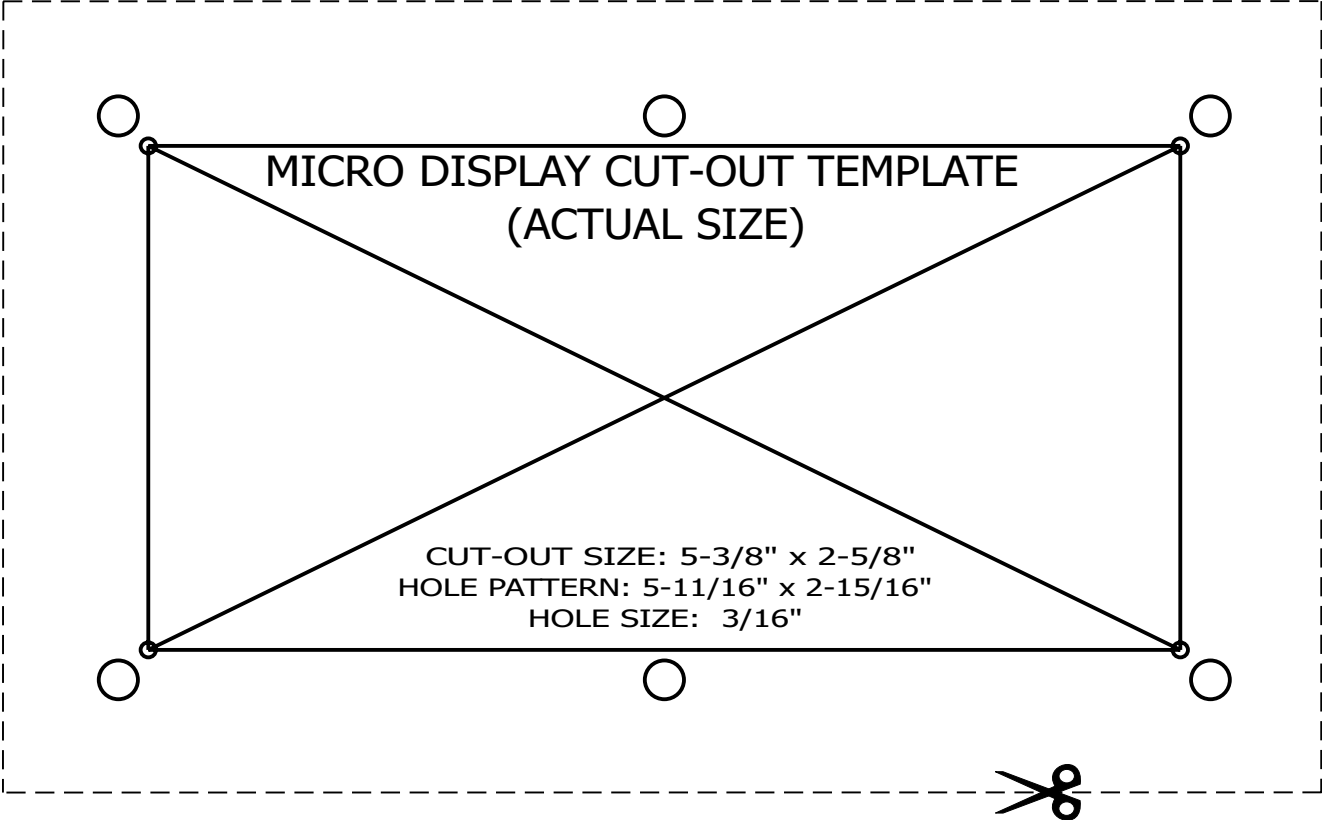

BENSHAW PRODUCTS

- Pump Duty Starters
- Wound Rotor Starters
- Chiller/Compressor starters
- Synchronous Motor Starters
- Medium Voltage Starters
- D.C. Injection Brakes
- Solid State Contactors
- Variable Voltage Controls

Electrical Solutions To Mechanical Problems™

Benshaw Canada Controls Inc.
R.R. #1 (Wallace Industrial Park)
Listowel, Ontario
N4W 3G6
Phone: 519-291-5112
Fax: 519-291-2595

Benshaw Inc.
1659 East Sutter Road
Glenshaw, PA 15116
Phone: 412-487-8235
Fax: 412-487-4201

Benshaw West
7820 E. Evans Drive, Suite 900
Scottsdale, AZ 85260
Phone: 480-905-0601
Fax: 480-905-0757

Web: www.benshaw.com

E-mail: info@benshaw.com