

EMX4i

Low Voltage Soft Starter User Guide



BENSHAW
Applied Motor Controls

710-21919-00D

©2025 Benshaw, Inc

Benshaw retains the right to change specifications and illustrations in text without prior notification.
The contents of this document may not be copied without the explicit permission of Benshaw.

Compatibility

This user manual is suitable for use with EMX4i soft starters running user interface software 3.x. To check the software version, use Setup Tools > Software Versions. For other versions, contact your local distributor.

Certifications



Contents

1.	About this manual	4
1.1	Disclaimer	4
2.	Caution statements	5
2.1	Electrical shock risk	5
2.2	Unexpected operation	6
2.3	Avertissements à l'attention des clients canadiens	7
3.	System design	9
3.1	Feature list	9
3.2	Model code	10
3.3	Model selection	11
3.4	Current ratings	12
3.5	Dimensions and weights	18
3.6	Physical installation	20
3.7	Accessories	21
3.8	Main contactor or circuit breaker	22
3.9	External bypass contactor	23
3.10	Power factor correction	23
3.11	Short circuit protection devices (SCPD)	24
3.12	IEC coordination with short circuit protection devices	25
3.13	UL coordination with short circuit protection devices	27
3.14	Specifications	43
3.15	Disposal instructions	46
4.	Installation	47
4.1	Command source	47
4.2	Setup procedure overview	47
4.3	Inputs	48
4.4	Outputs	50
4.5	Control voltage	52
4.6	Power terminations	53
4.7	External bypass contactor	56
4.8	Motor connection	57
4.9	Earth terminations	60
4.10	Typical installation	61
4.11	Quick setup	65
5.	Setup tools	66
5.1	Set date and time	66
5.2	Command source	66
5.3	Commissioning	66
5.4	Run simulation	67
5.5	Load/save settings	68
5.6	USB save and load	68
5.7	Auto-start/stop	70
5.8	Network address	71
5.9	Digital I/O state	72
5.10	Analog I/O state	72
5.11	Serial number and rating	72

5.12 Software versions	73
5.13 Thermistor reset	73
5.14 Reset thermal model.....	73
6. Logs.....	74
6.1 Event logs.....	74
6.2 Counters	74
6.3 QR code	74
7. Keypad and feedback.....	75
7.1 The keypad.....	75
7.2 Remote keypad	76
7.3 Lighten/darken the display.....	76
7.4 Starter status LEDs.....	77
7.5 Displays	78
8. Operation.....	80
8.1 Start, stop and reset commands.....	80
8.2 Command override	80
8.3 Solid state overload protection	81
8.4 Auto-start/stop	83
8.5 PowerThrough	84
8.6 Emergency mode	85
8.7 Auxiliary trip	85
8.8 Typical control methods.....	86
8.9 Soft start methods	88
8.10 Stop methods	91
8.11 Pump clean.....	95
8.12 Reverse direction operation.....	96
8.13 Jog operation.....	98
8.14 Inside delta operation	99
8.15 Secondary motor set.....	100
9. Programmable parameters	101
9.1 Main menu.....	101
9.2 Altering parameter values.....	101
9.3 Adjustment lock	101
9.4 Parameter list	102
9.5 1 Motor Details	108
9.6 2 Motor Start/Stop	110
9.7 3 Motor Start/Stop-2	113
9.8 4 Auto-Start/Stop	116
9.9 5 Protection Levels	118
9.10 6 Protection Action.....	122
9.11 7 Inputs.....	127
9.12 8 Relay Outputs.....	131
9.13 9 Analog Output.....	134
9.14 10 Display.....	135
9.15 11 Pump Clean.....	138
9.16 12 Communications Card	139
9.17 20 Advanced.....	142
9.18 30 Smart Card Parameters.....	144

9.19 40 Ground Fault.....	144
9.20 41 Calibrate 4-20mA.....	145
10. Troubleshooting.....	146
10.1 Protection responses.....	146
10.2 Trip messages.....	146
10.3 General faults.....	156

1. About this manual



WARNING

Indicates a hazard that may cause personal injury or death.



CAUTION

Indicates a hazard that may damage the equipment or installation.



NOTE

Provides helpful information.

1.1 Disclaimer

The examples and diagrams in this manual are included solely for illustrative purposes.

The information contained in this manual is subject to change at any time and without prior notice. In no event will responsibility or liability be accepted for direct, indirect or consequential damages resulting from the use or application of this equipment.

© 2025 AuCom Electronics Ltd. All Rights Reserved.

As AuCom is continuously improving its products it reserves the right to modify or change the specification of its products at any time without notice. The text, diagrams, images and any other literary or artistic works appearing in this document are protected by copyright. Users may copy some of the material for their personal reference but may not copy or use material for any other purpose without the prior consent of AuCom Electronics Ltd. AuCom endeavours to ensure that the information contained in this document including images is correct but does not accept any liability for error, omission or differences with the finished product.

2. Caution statements

Caution statements cannot cover every potential cause of equipment damage but can highlight common causes of damage. It is the installer's responsibility to read and understand all instructions in this manual prior to installing, operating or maintaining the equipment, to follow good electrical practice including applying appropriate personal protective equipment and to seek advice before operating this equipment in a manner other than as described in this manual.



NOTE

The starter is not user serviceable. The unit should only be serviced by authorised service personnel. **Unauthorised tampering with the unit will void the product warranty.**



FOR YOUR SAFETY

- The STOP function of the soft starter does not isolate dangerous voltages from the output of the starter. The soft starter must be disconnected by an approved electrical isolation device before accessing electrical connections.
- Soft starter protection features apply to motor protection only. It is the user's responsibility to ensure safety of personnel operating machinery.
- The soft starter is a component designed for integration within an electrical system; it is therefore the responsibility of the system designer/user to ensure the system is safe and designed to comply with relevant local safety standards.

2.1 Electrical shock risk



WARNING – ELECTRICAL SHOCK HAZARD

The voltages present in the following locations can cause severe electric shock and may be lethal:

- AC supply cables and connections
- Output cables and connections
- Many internal parts of the starter



SHORT CIRCUIT

The equipment is not short circuit proof. After severe overload or short circuit, the operation of the equipment should be fully tested by an authorised service agent.



GROUNDING AND BRANCH CIRCUIT PROTECTION

It is the responsibility of the user or person installing the equipment to provide proper grounding and branch circuit protection according to local electrical safety codes.

2.2 Unexpected operation



WARNING – ACCIDENTAL STARTS

In some installations, accidental starts may pose an increased risk to safety of personnel or damage to the machines being driven. In such cases, it is recommended that the power supply to the soft starter is fitted with an isolating switch and a circuit-breaking device (eg power contactor) controllable through an external safety system (eg emergency stop, fault detector).



WARNING – STARTER MAY START OR STOP UNEXPECTEDLY

The EMX4i will respond to control commands from various sources, and could start or stop unexpectedly. Always disconnect the soft starter from mains voltage before accessing the starter or load.



WARNING – DISCONNECT MAINS BEFORE ACCESSING STARTER OR LOAD

The soft starter has built-in protections which can trip the starter in the event of faults and thus stop the motor. Voltage fluctuations, power cuts and motor jams may also cause the motor to trip.

The motor could restart after the causes of shutdown are rectified, which may be dangerous for personnel. Always disconnect the soft starter from mains voltage before accessing the starter or load.



CAUTION – MECHANICAL DAMAGE FROM UNEXPECTED RESTART

The motor could restart after the causes of shutdown are rectified, which may be dangerous for certain machines or installations. In such cases, it is essential that appropriate arrangements are made against restarting after unscheduled stops of the motor.

2.3 Avertissements à l'attention des clients canadiens



AVERTISSEMENT

L'icône AVERTISSEMENT ci-contre signale les informations concernant des risques pouvant entraîner des blessures graves, voire mortelles. Pour votre sécurité, veuillez consulter les avertissements sur cette page ou demander une copie du présent manuel en français auprès de votre distributeur local.



AVERTISSEMENT – RISQUE DE CHOC ÉLECTRIQUE

Les zones suivantes sont soumises à des tensions pouvant provoquer des risques de chocs électriques graves, voire mortels :

- Raccordement et câbles d'alimentation AC
- Câbles et raccordements de sortie
- De nombreuses pièces internes du démarreur



PAR SÉCURITÉ

- La fonction STOP du démarreur progressif n'isole pas des tensions dangereuses de la sortie du démarreur. Le démarreur progressif doit être déconnecté par un dispositif d'isolement électrique approprié avant d'accéder aux connexions électriques.
- Les fonctions de protection du démarreur progressif ne concernent que la protection du moteur. Il relève de la responsabilité de l'utilisateur d'assurer la sécurité des personnes travaillant sur les machines.
- Le démarreur progressif est un appareil conçu pour s'intégrer dans un système électrique ; il relève donc de la responsabilité du concepteur ou de l'utilisateur de veiller à ce que ce système soit sûr et conçu selon les normes de sécurité locales en vigueur.



AVERTISSEMENT – DÉMARRAGES ACCIDENTELS

Dans certaines installations, des démarrages accidentels peuvent provoquer un risque supplémentaire pour la sécurité des personnes ou endommager les machines contrôlées. Dans de tels cas, il est recommandé de doter l'alimentation du démarreur progressif d'un interrupteur d'isolement et d'un coupe-circuit (par exemple, un disjoncteur) contrôlable à partir d'un système de sécurité externe (par exemple, un arrêt d'urgence, un détecteur de défaut).



AVERTISSEMENT – LE DÉMARREUR PEUT DÉMARRER OU S'ARRÊTER À TOUT MOMENT

Le démarreur progressif répond aux commandes de contrôle de différentes origines et peut par conséquent démarrer ou s'arrêter à tout moment. Toujours déconnecter le démarreur de la tension secteur avant d'accéder au démarreur ou à la charge.



AVERTISSEMENT – DÉCONNECTER L'ALIMENTATION PRINCIPALE AVANT D'ACCÉDER AU DÉMARREUR OU À LA CHARGE

Le démarreur progressif comporte des protections intégrées qui peuvent déclencher des mises en sécurité dans l'éventualité de défauts et ainsi arrêter le moteur. Des fluctuations de tension, des coupures d'alimentation et des blocages du moteur peuvent produire des mises en sécurité de celui-ci.

Le moteur pourrait redémarrer une fois que les causes de l'arrêt ont été résolues, ce qui pourrait mettre en danger le personnel. Toujours déconnecter le démarreur de la tension secteur avant d'accéder au démarreur ou à la charge.



AVERTISSEMENT

Ne pas appliquer la tension du secteur au démarreur tant que tout le câblage n'est pas terminé.



AVERTISSEMENT

Toujours appliquer la tension de commande avant (ou en même temps que) la tension secteur.



AVERTISSEMENT

Lors du raccordement du EMX4i en connexion 6 fils, toujours installer un contacteur principal ou un disjoncteur magnéto-thermique à bobine de déclenchement.



AVERTISSEMENT

Si l'entrée de démarrage est fermée lorsque la tension de commande est appliquée, le démarreur tentera d'effectuer un démarrage.

Vérifier que l'entrée de démarrage/arrêt est ouverte avant d'appliquer la tension de commande.

3. System design

3.1 Feature list

Streamlined setup process

- Configuration profiles for common applications
- Built-in metering and display of inputs/outputs status

Easy to understand interface

- Multi-language menus and displays
- Descriptive parameter names and feedback messages
- Real-time performance graphs

Supports energy efficiency

- IE3 compatible
- 99% energy efficient when running
- Soft start technology avoids harmonic distortion

Extensive range of models

- 24 A~1250 A (nominal)
- 200~525 VAC
- 380~690 VAC
- Bypassed or continuous options
- In-line or inside delta connection

Extensive input and output options

- Remote control inputs
(2 x fixed function, 2 x programmable)
- Relay outputs
(2 x fixed function, 2 x programmable)
- Analog output

Versatile starting and stopping options

- Scheduled start/stop
- Adaptive Control
- Constant Current
- Current ramp
- Pump Clean
- Timed voltage ramp soft stop
- Coast to stop
- DC Brake
- Soft Brake
- Reverse Direction

Customisable protection

- Motor overload
- Excess Start Time
- Undercurrent/Overcurrent
- Underpower/Overpower
- Undervoltage/Overvoltage
- Current imbalance
- Input Trip
- Motor thermistor

Optional features for advanced applications

- Smart cards
- Communication options:
DeviceNet, EtherNet/IP, Modbus RTU, Modbus TCP, Profibus, Profinet
- Ground fault protection

3.2 Model code

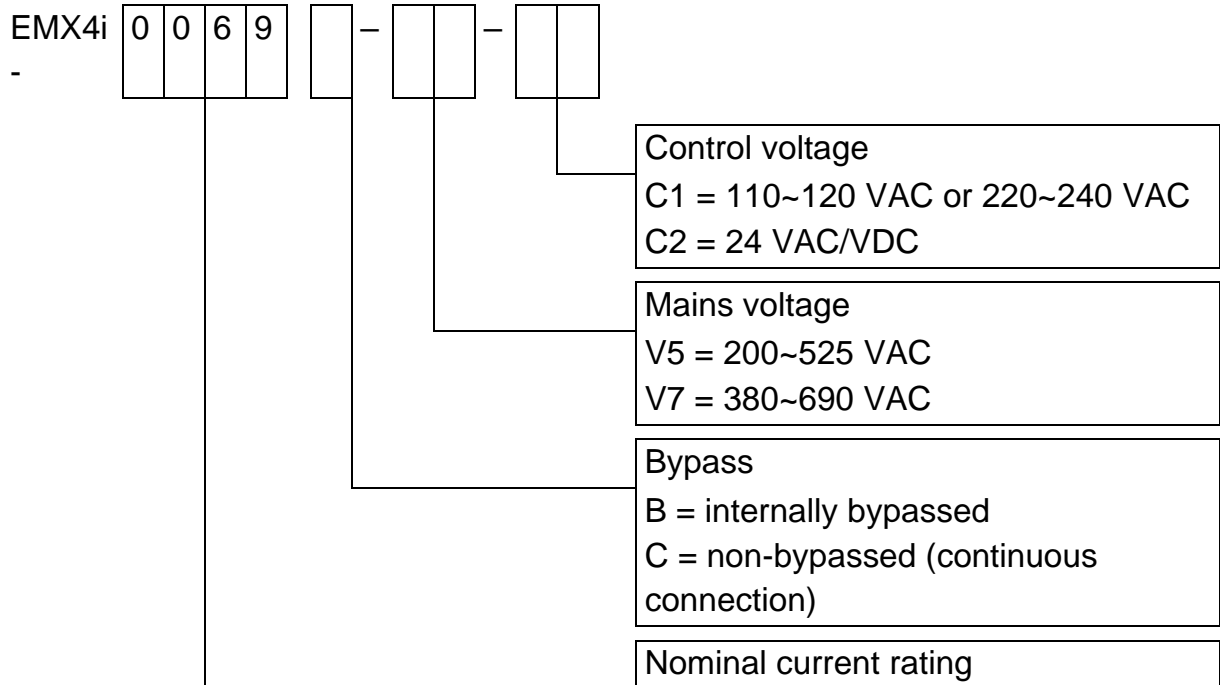

3.3 Model selection

Starter sizing

The soft starter must be the correct size for the motor and the application.

Select a soft starter that has a current rating at least equal to the motor's full load current (nameplate) rating, at the start duty.

The soft starter's current rating determines the maximum motor size it can be used with. The rating depends on the number of starts per hour, the length and current level of the start, and the amount of time the soft starter will be off (not passing current) between starts.

The soft starter's current rating is only valid when used in the conditions specified in the AC-53/AC-3 utilisation code. The current rating may be higher or lower in different operating conditions.

AC-53b/AC-3b format (bypassed current rating)

80 A : AC-53b 3.5 - 15 : 345

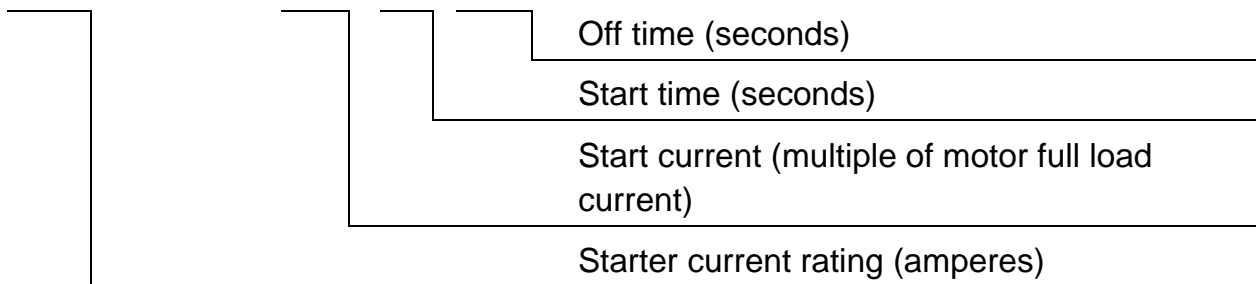

AC53a format (non-bypassed current rating)

351 A : AC-53a 3.5 - 15 : 50 - 6

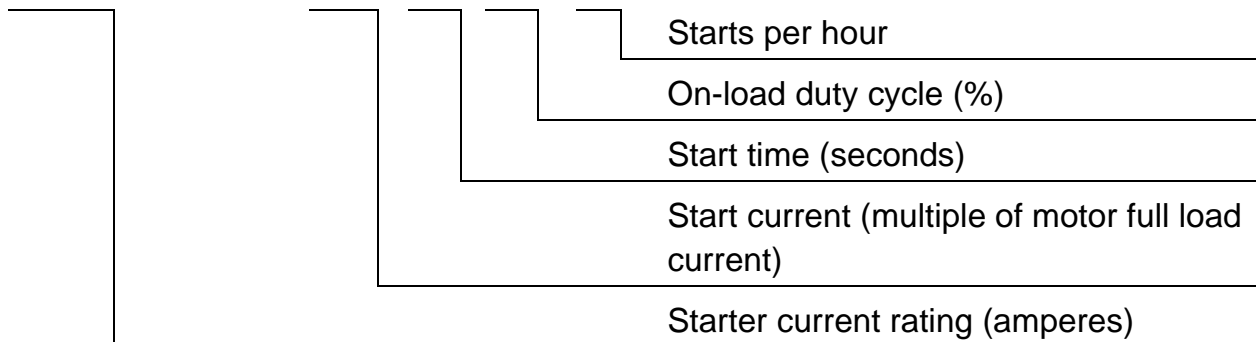

3.4 Current ratings

Contact your local supplier for ratings under operating conditions not covered by these ratings charts.

IEC ratings

All ratings are calculated at altitude of up to 1000 metres and ambient temperature of 40 °C.

- **In-line installation, bypassed**

	3.0-10:350	3.5-15:345	4.0-10:350	4.0-20:340	5.0-5:355
EMX4i-0024B	24	20	19	16	16
EMX4i-0042B	42	34	34	27	31
EMX4i-0052B	52	41	39	34	34
	3.0-10:590	3.5-15:585	4.0-10:590	4.0-20:580	5.0-5:595
EMX4i-0064B	64	62	60	50	53
EMX4i-0069B	69	69	69	62	64
EMX4i-0105B	105	86	84	68	76
EMX4i-0115B	115	107	104	86	95
EMX4i-0135B	135	129	126	103	115
EMX4i-0184B	184	143	139	115	127
EMX4i-0200B	200	170	165	138	150
EMX4i-0229B	229	194	187	157	170
EMX4i-0250B	250	244	230	200	202
EMX4i-0352B	352	285	277	234	257
EMX4i-0397B	397	322	311	262	288
EMX4i-0410B	410	410	410	379	400
EMX4i-0550B	550	526	505	427	462
EMX4i-0580B	580	578	554	469	507
EMX4i-0835B	835	654	630	535	592
EMX4i-0940B	940	736	708	603	663
EMX4i-1070B	1070	950	905	785	834
EMX4i-1230B	1230	1154	1090	959	989
EMX4i-1250B	1250	1250	1250	1155	1250
	3.0-10:590	3.5-15:585	4.0-10:590	4.0-20:580	5.0-5:595
EMX4i-0184E	184	143	139	115	127
EMX4i-0200E	200	170	165	138	150
EMX4i-0229E	229	194	187	157	170

	3.0-10:590	3.5-15:585	4.0-10:590	4.0-20:580	5.0-5:595
EMX4i-0250E	250	244	230	200	202
EMX4i-0352E	352	285	277	234	257
EMX4i-0397E	397	322	311	262	288
EMX4i-0410E	410	410	410	379	400
EMX4i-0550E	550	526	505	427	462
EMX4i-0580E	580	578	554	469	507
EMX4i-0735C	835	732	716	593	695
EMX4i-0830C	940	822	803	667	776
EMX4i-1025C	1210	1067	1033	874	982
EMX4i-1170C	1430	1307	1252	1076	1170
EMX4i-1220C	1620	1620	1616	1309	1620

**NOTE**

Models EMX4i-0735C~EMX4i-1220C must be installed with an external bypass contactor to achieve the bypassed current ratings.

- In-line installation, non-bypassed**

	3.0-10:50-6	3.5-15:50-6	4.0-10:50-6	4.0-20:50-6	5.0-5:50-6
EMX4i-0735C	735	590	572	492	542
EMX4i-0830C	830	667	645	557	609
EMX4i-1025C	1025	839	805	710	751
EMX4i-1170C	1170	979	934	838	862
EMX4i-1220C	1220	1134	1109	964	1075

SYSTEM DESIGN

- **Inside delta installation, bypassed**

	3.0-10:350	3.5-15:345	4.0-10:350	4.0-20:340	5.0-5:355
EMX4i-0024B	36	30	29	24	24
EMX4i-0042B	63	51	51	41	47
EMX4i-0052B	78	62	59	51	51
	3.0-10:590	3.5-15:585	4.0-10:590	4.0-20:580	5.0-5:595
EMX4i-0064B	96	93	90	75	80
EMX4i-0069B	104	104	104	93	96
EMX4i-0105B	158	129	126	102	114
EMX4i-0115B	173	161	156	129	143
EMX4i-0135B	203	194	189	155	173
EMX4i-0184B	276	215	209	173	191
EMX4i-0200B	300	255	248	207	225
EMX4i-0229B	344	291	281	236	255
EMX4i-0250B	375	366	345	300	303
EMX4i-0352B	528	428	415	351	386
EMX4i-0397B	596	484	466	393	433
EMX4i-0410B	615	615	615	568	600
EMX4i-0550B	825	789	758	640	694
EMX4i-0580B	870	868	832	704	760
EMX4i-0835B	1253	981	945	803	888
EMX4i-0940B	1410	1104	1062	905	995
EMX4i-1070B	1605	1425	1358	1178	1251
EMX4i-1230B	1845	1731	1635	1439	1484
EMX4i-1250B	1875	1875	1875	1733	1875
EMX4i-0184E	184	143	139	115	127
EMX4i-0200E	200	170	165	138	150
EMX4i-0229E	229	194	187	157	170
EMX4i-0250E	250	244	230	200	202
EMX4i-0352E	352	285	277	234	257
EMX4i-0397E	397	322	311	262	288
EMX4i-0410E	410	410	410	379	400
EMX4i-0550E	550	526	505	427	462
EMX4i-0580E	580	578	554	469	507
EMX4i-0735C	1253	1098	1074	890	1043
EMX4i-0830C	1410	1233	1205	1001	1164

	3.0-10:590	3.5-15:585	4.0-10:590	4.0-20:580	5.0-5:595
EMX4i-1025C	1815	1601	1550	1311	1473
EMX4i-1170C	2145	1961	1878	1614	1755
EMX4i-1220C	2430	2430	2424	1964	2430

**NOTE**

Models EMX4i-0735C~EMX4i-1220C must be installed with an external bypass contactor to achieve the bypassed current ratings.

- **Inside delta installation, non-bypassed**

	3.0-10:50-6	3.5-15:50-6	4.0-10:50-6	4.0-20:50-6	5.0-5:50-6
EMX4i-0735C	1103	885	858	738	813
EMX4i-0830C	1245	1001	968	836	914
EMX4i-1025C	1538	1259	1208	1065	1127
EMX4i-1170C	1755	1469	1401	1257	1293
EMX4i-1220C	1830	1701	1664	1446	1613

NEMA motor ratings

All ratings are calculated at altitude up to 1000 metres and ambient temperature of 50 °C.

- **In-line installation, bypassed**

	Normal 350%, 30 s, 4 starts per hour				Heavy 450%, 30 s, 4 starts per hour			
	A	hp @240 VA C	hp @480 VA C	hp @600 VA C	A	hp @240 VA C	hp @480 VA C	hp @600 VA C
EMX4i-0024B	17	5	10	15	14	3	10	10
EMX4i-0042B	28	10	20	25	22	7.5	15	20
EMX4i-0052B	35	10	25	30	28	10	20	25
EMX4i-0064B	52	15	40	40	40	10	25	30
EMX4i-0069B	59	20	40	50	46	15	30	40
EMX4i-0105B	77	25	60	60	52	15	40	50
EMX4i-0115B	81	30	60	75	65	20	50	60
EMX4i-0135B	99	30	75	100	77	25	60	75
EMX4i-0184B	124	40	100	100	96	30	75	75
EMX4i-0200B	131	50	100	125	104	40	75	100
EMX4i-0229B	156	60	125	150	124	40	100	100
EMX4i-0250B	195	75	150	200	156	60	125	150
EMX4i-0352B	240	75	200	200	180	60	150	150
EMX4i-0397B	261	100	200	250	203	75	150	200
EMX4i-0410B	377	150	300	350	302	100	250	300
EMX4i-0550B	414	150	350	450	321	125	250	300
EMX4i-0580B	477	200	400	500	361	150	300	350
EMX4i-0835B	515	200	450	500	414	150	350	450
EMX4i-0940B	590	200	500	600	480	200	400	500
EMX4i-1070B	797	300	600	800	620	250	500	600
EMX4i-1230B	985	400	800	1000	768	300	600	800
EMX4i-1250B	1180	500	900	1200	904	350	700	900
EMX4i-0184E	124	40	75	100	96	30	60	75
EMX4i-0200E	131	50	100	125	104	40	75	100
EMX4i-0229E	156	60	125	150	124	40	100	100
EMX4i-0250E	195	75	150	200	156	60	125	150
EMX4i-0352E	240	75	150	200	180	60	150	150

	Normal 350%, 30 s, 4 starts per hour				Heavy 450%, 30 s, 4 starts per hour			
	A	hp @240 C	hp @480 C	hp @600 C	A	hp @240 C	hp @480 C	hp @600 C
EMX4i-0397E	261	100	200	250	203	75	150	200
EMX4i-0410E	377	150	300	350	302	100	250	300
EMX4i-0550E	414	150	350	450	321	125	250	300
EMX4i-0580E	477	200	400	500	361	150	300	350
EMX4i-0735C	551	200	450	500	429	150	350	450
EMX4i-0830C	634	250	500	600	493	200	400	500
EMX4i-1025C	882	350	700	900	686	250	500	700
EMX4i-1170C	1100	450	900	1100	864	350	700	900
EMX4i-1220C	1320	500	1100	1300	1030	450	800	1000

• In-line installation, non-bypassed

	Normal 350%, 30 s, 4 starts per hour				Heavy 450%, 30 s, 4 starts per hour			
	A	hp @240 VAC	hp @480 VAC	hp @600 VAC	A	hp @240 VAC	hp @480 VAC	hp @600 VAC
EMX4i-0735C	480	200	400	500	382	150	300	400
EMX4i-0830C	576	200	450	600	431	150	350	450
EMX4i-1025C	722	300	600	700	590	200	500	600
EMX4i-1170C	864	350	700	900	722	300	600	700
EMX4i-1220C	966	400	800	1000	784	300	600	800

3.5 Dimensions and weights

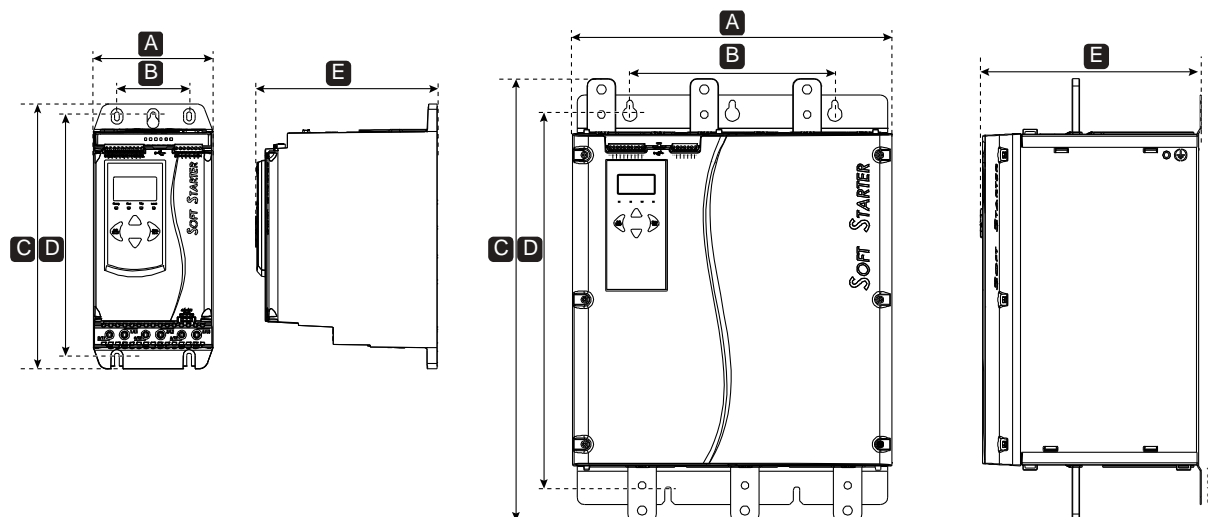

	Width mm (inch)		Height mm (inch)		Depth mm (inch)	Weight kg (lb)
	A	B	C	D	E	
EMX4i-0024B						4.8
EMX4i-0042B						(10.7)
EMX4i-0052B						4.9
EMX4i-0064B	152	92	336	307	233	(10.9)
EMX4i-0069B	(6.0)	(3.6)	(13.2)	(12.1)	(9.2)	
EMX4i-0105B						5.5
EMX4i-0115B						(12.1)
EMX4i-0135B						
EMX4i-0184B						12.7
EMX4i-0200B	216	180	495	450	245	(28.0)
EMX4i-0229B	(8.5)	(7.1)	(19.5)	(17.7)	(9.6)	
EMX4i-0250B						
EMX4i-0352B						15.5
EMX4i-0397B						(34.2)
EMX4i-0410B	216	180	523	450	245	
EMX4i-0550B	(8.5)	(7.1)	(20.6)	(17.7)	(9.6)	19.0
EMX4i-0580B						(41.9)

	Width mm (inch)		Height mm (inch)		Depth mm (inch)	Weight kg (lb)
	A	B	C	D	E	
EMX4i-0835B						51.0
EMX4i-0940B						(112.4)
EMX4i-1070B	447	287	618	525	310	62.0
EMX4i-1230B	(17.6)	(11.3)	(24.3)	(20.7)	(12.3)	(136.7)
EMX4i-1250B						63.0
						(138.9)
EMX4i-1250B						65.0
						(143.3)
EMX4i-0184E						
EMX4i-0200E						11.8
EMX4i-0229E						(26.0)
EMX4i-0250E	216	180	523	450	245	
EMX4i-0352E	(8.5)	(7.1)	(20.6)	(17.7)	(9.6)	12.3
EMX4i-0397E						(27.1)
EMX4i-0410E						
EMX4i-0550E						15.4
EMX4i-0580E						(34.0)
EMX4i-0735C						47.0
EMX4i-0830C						(103.6)
EMX4i-1025C	447	287	618	525	310	58.0
EMX4i-1170C	(17.6)	(11.3)	(24.3)	(20.7)	(12.3)	(127.9)
EMX4i-1220C						59.0
						(130.1)
EMX4i-1220C						61.0
						(134.5)

3.6 Physical installation

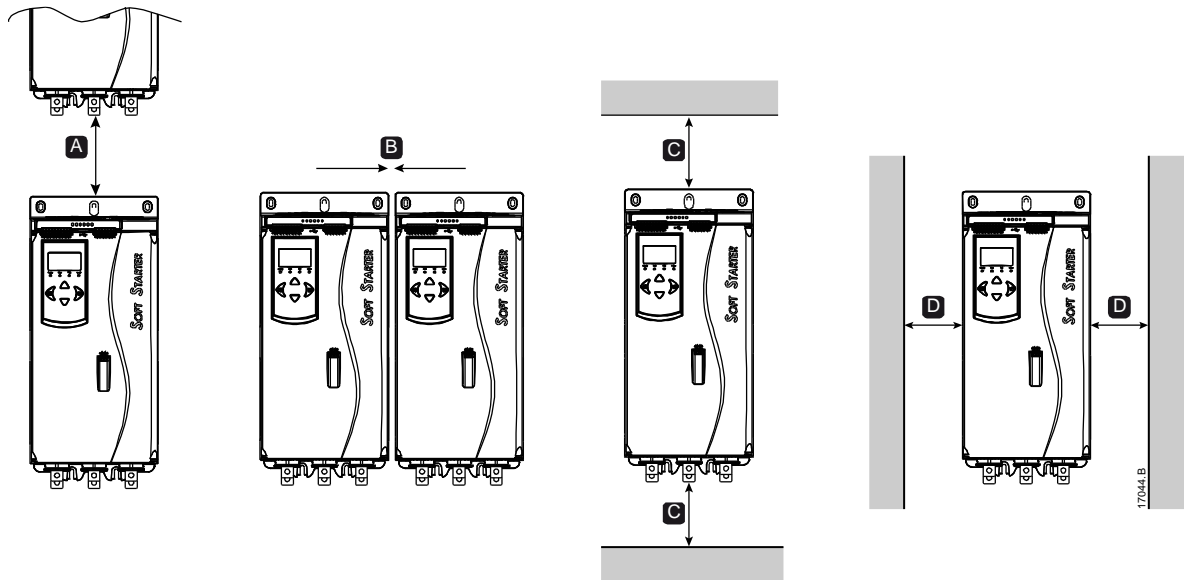

Between starters		Solid surfaces	
A	B	C	D
> 100 mm (3.9 inch)	> 10 mm (0.4 inch)	> 100 mm (3.9 inch)	> 10 mm (0.4 inch)

3.7 Accessories

Expansion cards

The EMX4i offers expansion cards for users requiring additional inputs and outputs or advanced functionality. Each EMX4i can support a maximum of one expansion card.

- **Pumping smart card**

The pumping smart card has been designed to support integration with pumping applications and provides the following additional inputs and outputs:

- 4 x digital inputs
- 3 x 4-20 mA transducer inputs
- 1 x RTD input
- 1 x USB-B port
- Remote keypad connector

- **Communications expansion cards**

The EMX4i supports network communication via easy-to-install communications expansion cards. Each communications card includes a remote keypad connector port.

Available protocols:

DeviceNet, EtherNet/IP, Modbus RTU, Modbus TCP, Profibus, Profinet.

- **Ground fault protection**

The soft starter can detect ground current and trip before the equipment is damaged.

Ground fault protection requires a 1000:1 or 2000:1 current transformer (not supplied). The CT should be rated 1 VA or 5 VA. Ground fault protection is available as an option with specific versions of the Modbus RTU, Modbus TCP, EtherNet/IP and Profinet expansion cards.

Remote keypad

The EMX4i can be used with a remote keypad, mounted up to 3 metres away from the starter. Each expansion card includes a keypad connection port, or a dedicated keypad connector card is available.

Finger guard kit

Finger guards may be specified for personnel safety. Finger guards fit over the soft starter terminals to prevent accidental contact with live terminals. Finger guards provide IP20 protection when used with cable of diameter 22 mm or greater.

Finger guards are available for models EMX4i-0184B~EMX4i-1250B. Finger guards are not available for models EMX4i-0184E~EMX4i-0580E or EMX4i-0735C~EMX4i-1220C.

Finger guards must be fitted to all terminals, even if no cable is connected. Contact your local supplier for assistance selecting the correct finger guard kit.

WinMaster soft starter management software

WinMaster PC software can provide real-time or offline management of soft starters.

- For real-time management in a network of up to 254 starters, the software must connect to the soft starter via a Modbus TCP or Modbus RTU card. The software can monitor, control and program the starter across the network.
- The software can be used to program the starter via the USB port on the pumping smart card.
- For offline management, a configuration file generated in the software can be loaded into the starter via the USB port.

3.8 Main contactor or circuit breaker

A main contactor or circuit breaker should be installed with the soft starter.

- A main contactor is recommended to protect the soft starter from voltage disturbances on the network, while stopped. Select a contactor with an AC-3 rating greater than or equal to the full load current rating of the connected motor.
- Use a shunt trip circuit breaker to isolate the motor circuit in the event of a soft starter trip. The shunt trip mechanism must be powered from the supply side of the circuit breaker or from a separate control supply.

Use the main contactor output (33, 34) to control the main contactor.



WARNING

When connecting the EMX4i in inside delta configuration, always install a main contactor or shunt trip circuit breaker.

3.9 External bypass contactor

Models EMX4i-0184E~EMX4i-0580E and EMX4i-0735C~EMX4i-1220C can be installed with an external bypass contactor. Bypassing the soft starter increases the soft starter's maximum current rating, and allows the motor to be started direct on-line (across the line) if the soft starter is damaged.

- To bypass the soft starter during run, use an external bypass contactor with an AC1 rating.
- To bypass the soft starter completely (to allow direct on-line starting if the starter is damaged), use an external bypass contactor with an AC3 rating.

3.10 Power factor correction

To use the starter to control power factor correction, connect the PFC contactor to a programmable relay set to 'Run'. When the motor reaches full speed, the relay will close and power factor correction will be switched in. Do not use the soft starter relay output to directly switch in power factor correction.

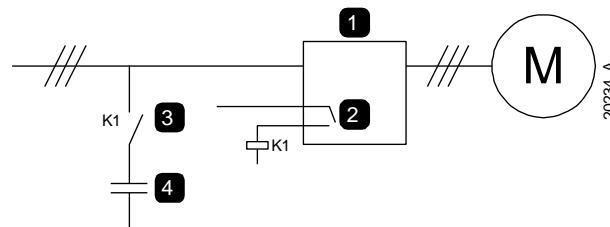

1	Soft starter
2	Programmable output (set = Run)
3	Power factor correction contactor
4	Power factor correction



CAUTION

Power factor correction capacitors must be connected to the input side of the soft starter. Connecting power factor correction capacitors to the output side will damage the soft starter.

3.11 Short circuit protection devices (SCPD)

Fuses may be installed to protect the soft starter or the installation.

Type 1 coordination

Type 1 coordination requires that, in the event of a short circuit on the output side of a soft starter, the fault must be cleared without risk of injury to personnel. There is no requirement that the soft starter must remain operational after the fault.

HRC fuses (such as Ferraz/Mersen AJT fuses) can be used for Type 1 coordination according to IEC 60947-4-2 standard.

Type 2 coordination

Type 2 coordination requires that in the event of a short circuit on the output side of a soft starter, the fault must be cleared without risk of injury to personnel or damage to the soft starter.

Semiconductor fuses for Type 2 circuit protection are additional to HRC fuses or MCCBs that form part of the motor branch circuit protection.



CAUTION

DC Brake: A high brake torque setting can result in peak currents up to motor DOL being drawn while the motor is stopping. Ensure protection fuses installed in the motor branch circuit are selected appropriately.



CAUTION

Integral solid state short circuit protection does not provide branch circuit protection. Branch circuit protection must be provided in accordance with the National Electrical Code and any additional local codes.

3.12 IEC coordination with short circuit protection devices

HRC fuse codes beginning OFAA are for ABB fuses. All other fuse codes are for Bussmann fuses.

Models EMX4i-0024B~EMX4i-0580B & EMX4i-0184E~EMX4i-0580E

These fuses were selected based on start current of 300% FLC for 10 seconds.

Model	Nominal rating (A) 300%, 10 s	SCR I ² t (A ² s)	Type 1 coordination 480 VAC, 65 kA	Type 2 coordination 690 VAC, 65 kA
EMX4i-0024B	24	1150	40NHG000B	170M3010
EMX4i-0042B	42	7200	63NHG000B	170M3013
EMX4i-0052B	52		80NHG000B	
EMX4i-0064B	64	15000	100NHG000B	170M3014
EMX4i-0069B	69			
EMX4i-0105B	105	80000	160NHG000B	170M3015
EMX4i-0115B	115			
EMX4i-0135B	135	125000		170M3016
EMX4i-0184B	184	320000	250NHG2B	170M3020
EMX4i-0200B	200			
EMX4i-0229B	229		315NHG2B	170M3021
EMX4i-0250B	250			
EMX4i-0352B	352	202000	355NHG2B	170M6009
EMX4i-0397B	397		400NHG2B	
EMX4i-0410B	410	320000	425NHG2B	170M6010
EMX4i-0550B	550	781000	630NHG3B	170M6012
EMX4i-0580B	580			
EMX4i-0184E	184	320000	250NHG2B	170M3020
EMX4i-0200E	200			
EMX4i-0229E	229		315NHG2B	170M3021
EMX4i-0250E	250			
EMX4i-0352E	352	202000	355NHG2B	170M6009
EMX4i-0397E	397		400NHG2B	
EMX4i-0410E	410	320000	425NGG2B	170M6010
EMX4i-0550E	550	781000	630NHG2B	170M6012
EMX4i-0580E	580			

Models EMX4i-0835B~EMX4i-1250B/EMX4i-0735C~EMX4i-1220C, bypassed installation

These fuses were selected based on start current of 350% FLC for 30 seconds.

Model	Nominal rating (A) 350%, 30 s	SCR I ² t (A ² s)	Type 1 coordination 500 VAC, 100 kA	Type 2 coordination 690 VAC, 100 kA
EMX4i-0835B	565	2530000	1000NHG4G	170M6016
EMX4i-0940B	638			170M6017
EMX4i-1070B	854	3920000	1200NHG4G	Not available
EMX4i-1230B	1055			OFAA5GG1250
EMX4i-1250B	1249	7220000	OFAA5GG1250	170M6019
EMX4i-0735C	621	2530000		1000NHG4G
EMX4i-0830C	699		170M6017	
EMX4i-1025C	945	3920000	OFAA5GG1250	Not available
EMX4i-1170C	1178			OFAA5GG1600
EMX4i-1220C	1403	7220000	OFAA5GG1600	170M6021 (at 500 VAC)

Models EMX4i-0735C~EMX4i-1220C, continuous connection

These fuses were selected based on start current of 350% FLC for 30 seconds.

	Nominal rating (A) 350%, 30 s	SCR I ² t (A ² s)	Type 1 coordination 500 VAC, 100 kA	Type 2 coordination 690 VAC, 100 kA
EMX4i-0735C	535	2530000	1000NHG4G	170M6016
EMX4i-0830C	605			170M6017
EMX4i-1025C	775	3920000	1200NHG4G	Not available
EMX4i-1170C	920			OFAA5GG1250
EMX4i-1220C	1044	7220000	OFAA5GG1250	170M6019

3.13 UL coordination with short circuit protection devices

Models marked as UL approved were tested with short circuit and overcurrent protection devices listed in the tables below.

Standard fault short circuit

- **Models EMX4i-0024B~EMX4i-0580B & EMX4i-0184E~EMX4i-0580E**

Suitable for use on a circuit capable of delivering up to the stated fault current, 600 VAC maximum, when protected by any UL listed fuses or circuit breakers sized according to the NEC.

Model	Nominal rating (A) 300%, 10 s	3-cycle short cct rating @600 VAC
EMX4i-0024B	24	5 kA
EMX4i-0042B	42	
EMX4i-0052B	52	
EMX4i-0064B	64	10 kA
EMX4i-0069B	69	
EMX4i-0105B	105	
EMX4i-0115B	120	
EMX4i-0135B	135	
EMX4i-0184B	184	
EMX4i-0200B	200	18 kA
EMX4i-0229B	229	
EMX4i-0250B	250	
EMX4i-0352B	352	
EMX4i-0397B	397	
EMX4i-0410B	410	
EMX4i-0550B	550	30 kA
EMX4i-0580B	580	
EMX4i-0184E	184	
EMX4i-0200E	200	18 kA
EMX4i-0229E	229	
EMX4i-0250E	250	
EMX4i-0352E	352	
EMX4i-0397E	397	
EMX4i-0410E	410	
EMX4i-0550E	550	30 kA

SYSTEM DESIGN

Model	Nominal rating (A) 300%, 10 s	3-cycle short cct rating @600 VAC
EMX4i-0580E	580	

- **Models EMX4i-0835B~EMX4i-1250B & EMX4i-0735C~EMX4i-1220C**

Suitable for use on a circuit capable of delivering up to the stated fault current, when protected by the specified circuit breaker, or by a class L fuse sized according to the NEC.

These protection devices were selected based on start current of 350% FLC for 30 seconds.

Model	Nominal rating (A) 350%, 30 s	@480 VAC	or 600 VAC	@480 VAC
		Fault current rating	Fuse rating (A, max) Class L	Circuit breaker rating (A, max)
EMX4i-0835B	565			
EMX4i-0940B	638	42 kA	1350	1200 A
EMX4i-1070B	854			
EMX4i-1230B	1055			1200 A
EMX4i-1250B	1249	85 kA	2500	1600 A
EMX4i-0735C	621			
EMX4i-0830C	699	42 kA	1350	1200 A
EMX4i-1025C	945			
EMX4i-1170C	1178			1200 A
EMX4i-1220C	1403	85 kA	2500	1600 A

High fault short circuit

Suitable for use on a circuit capable of delivering up to the stated fault current, when protected by the specified circuit breaker or by fuses of the stated class and rating.

- Circuit breakers with model codes beginning 3VA/CPD/HMD/HND/HPD are from Siemens.
- Circuit breakers with model codes beginning HFD/HJD/HKD/HLD are from Eaton.
- Circuit breakers with model codes beginning SELA/SFLA/SGLA are from GE.
- Circuit breakers with model codes beginning UTS are from LS Electric or Benschaw.

SYSTEM DESIGN

- **Models EMX4i-0024B~EMX4i-0580B & EMX4i-0184E~EMX4i-0580E**

Suitable for use on a circuit capable of delivering up to the stated fault current, when protected by the specified circuit breaker or by fuses of the stated class and rating.

These protection devices were selected based on start current of 300% FLC for 10 seconds.

		@480 VAC		
		Fault current 65 kA		
Model	Nominal rating (A) 300%, 10 s	Circuit breaker (rating, A)	Fuse rating (A, max)	Fuse class
EMX4i-0024B	24	HFD3030 (30 A)	30	
		SELA36AT0060 (60 A)		
		UTS150H-xxU-040 (40 A)		
		3VA*140-6****-**** (40A)		
EMX4i-0042B	42	HFD3050 (50 A)	50	
		SELA36AT0060 (60 A)		
		UTS150H-xxU-050 (50 A)		
		3VA*140-6****-**** (60A)		
EMX4i-0052B	52	HFD3060 (60 A)	60	Any (J, T, K-1, RK1, RK5)
		SELA36AT0060 (60 A)		
		UTS150H-xxU-060 (60 A)		
		3VA*140-6****-**** (70A)		
EMX4i-0064B	64	HFD3100 (100 A)	80	
		SELA36AT0150 (150 A)		
		UTS150H-xxU-100 (100 A)		
		3VA*140-6****-**** (100 A)		
EMX4i-0069B	69	HFD3100 (100 A)	80	
		SELA36AT0150 (150 A)		
		UTS150H-xxU-100 (100 A)		
		3VA*140-6****-**** (100 A)		

Model	Nominal rating (A) 300%, 10 s	Circuit breaker (rating, A)	Fuse rating (A, max)	Fuse class
EMX4i-0105B	105	HFD3125 (125 A) SELA36AT0150 (150 A) UTS150H-xxU-125 (125 A) 3VA*225-6****-**** (150 A)	125	
EMX4i-0115B	115	HFD3125 (125 A) SELA36AT0150 (150 A) UTS150H-xxU-125 (125 A) 3VA*225-6****-**** (150 A)	125	J, T, K-1, RK1
EMX4i-0135B	135	HFD3150 (150 A) SELA36AT0150 (150 A) UTS150H-xxU-150 (150 A) 3VA*225-6****-**** (250 A)	150	
EMX4i-0184B EMX4i-0184E	184	HJD3250 (250 A) SFLA36AT0250 (250 A) R2CB-250A-250F-xx-HF-FTU (250 A) UTS250H-xxU-250 (250 A) 3VA*225-6****-**** (250 A)	200	
EMX4i-0200B EMX4i-0200E	200	HJD3250 (250 A) SFLA36AT0250 (250 A) R2CB-250A-250F-xx-HF-FTU (250 A) UTS250H-xxU-250 (250 A) 3VA*225-6****-**** (250 A)	225	
EMX4i-0229B EMX4i-0229E	229	HJD3250 (250 A) SFLA36AT0250 (250 A) R2CB-250A-250F-xx-HF-FTU (250 A) UTS250H-xxU-250 (250 A) 3VA*340-6****-**** (400 A)	250	J, T
EMX4i-0250B EMX4i-0250E	250	HKD3300 (300 A) SGLA36AT0400 (400 A) R2CB-300A-400F-xx-HF-FTU (300 A) UTS400H-xxU-300 (300 A) 3VA*340-6****-**** (400 A)	300	

SYSTEM DESIGN

Model	Nominal rating (A) 300%, 10 s	Circuit breaker (rating, A)	Fuse rating (A, max)	Fuse class
EMX4i-0352B EMX4i-0352E	352	HLD3400 (400 A) SGLA36AT0600 (600 A) R2CB-400A-400F-xx-HF-FTU (400 A) UTS400H-xxU-400 (400 A) HMD63B800 (800 A)	400	
EMX4i-0397B EMX4i-0397E	397	HLD3400 (400 A) SGLA36AT0600 (600 A) R2CB-400A-400F-xx-HF-FTU (400 A) UTS400H-xxU-400 (400 A) HND63B900 (900 A)	450	
EMX4i-0410B EMX4i-0410E	410	HLD3600 (600 A) SGLA36AT0600 (600 A) R2CB-600A-600F-xx-HF-FTU (600 A) UTS600H-xxU-600 (600 A) HND63B100 (1000 A)	450	Any (J, T, K-1, RK1, RK5)
EMX4i-0550B EMX4i-0550E	550	HLD3600 (600 A) SGLA36AT0600 (600 A) R2CB-800A-800F-xx-HF-NGx (800 A) UTS800H-NGx-800 (800 A) HND63B120 (1200 A)	600	
EMX4i-0580B EMX4i-0580E	580	HLD3600 (600 A) SGLA36AT0600 (600 A) R2CB-800A-800F-xx-HF-NGx (800 A) UTS800H-NGx-800 (800 A) HND63B120 (1200 A)	600	

These protection devices were selected based on start current of 350% FLC for 30 seconds.

Model	Nominal rating (A) 350%, 30 s	@600 VAC		Fuse rating (A, max)	Fuse class
		Fault current 50 kA	Fault current 100 kA		
EMX4i-0024B	18	R2CB-40A-150F-xx-LF-FTU (40 A) UTS150LxxU-040 (40 A)		40	
EMX4i-0042B	30	R2CB-60A-150F-xx-LF-FTU (60 A) UTS150LxxU-060 (60 A)		60	
EMX4i-0052B	38	R2CB-70A-150F-xx-LF-FTU (70 A) UTS150LxxU-070 (70 A)		70	
EMX4i-0064B	52	R2CB-100A-150F-xx-LF-FTU (100 A) UTS150LxxU-100 (100 A)		100	Any (J, T, K-1, RK1, RK5)
EMX4i-0069B	64	R2CB-125A-150F-xx-LF-FTU (125 A) UTS150LxxU-125 (125 A)		125	
EMX4i-0105B	70	R2CB-150A-150F-xx-LF-FTU (150 A) UTS150LxxU-150 (150 A)		200	
EMX4i-0115B	88	R2CB-150A-150F-xx-LF-FTU (150 A) UTS150LxxU-150 (150 A)		250	
EMX4i-0135B	105	R2CB-250A-250F-xx-LF-FTU (250 A) UTS250LxxU-250 (250 A)		300	
EMX4i-0184B EMX4i-0184E	120	R2CB-300A-400F-xx-LF-FTU (300 A) UTS400LxxU-300 (300 A)		300	Any (J, T, K-1, RK1, RK5)
EMX4i-0200B EMX4i-0200E	144	R2CB-350A-400F-xx-LF-FTU (350 A) UTS400LxxU-350 (350 A)		350	
EMX4i-0229B EMX4i-0229E	164	R2CB-400A-400F-xx-LF-FTU (400 A) UTS400LxxU-400 (400 A)		400	
EMX4i-0250B EMX4i-0250E	212	R2CB-600A-800F-xx-LF-NGx (600 A) UTS800L-NGx-600 (600 A)		500	
EMX4i-0352B EMX4i-0352E	247	R2CB-800A-800F-xx-LF-NGx (800 A) UTS800L-NGx-800 (800 A)		700	L
EMX4i-0397B EMX4i-0397E	279	R2CB-1000A-1200F-xx-PF-NGx (900 A1) UTS1200P-NGx-1000 (900 A ¹)		700	

SYSTEM DESIGN

Model	Nominal rating (A) 350%, 30 s	Circuit breaker (rating, A)	Fuse rating (A, max)	Fuse class
EMX4i-0410B EMX4i-0410E	404	R2CB-1000A-1200F-xx-PF-NGx (1000 A) UTS1200P-NGx-1000 (1000 A)	800	
EMX4i-0550B EMX4i-0550E	449	R2CB-1200A-1200F-xx-PF-NGx (1200 A) UTS1200P-NGx-1200 (1200 A)	900	
EMX4i-0580B EMX4i-0580E	495	R2CB-1200A-1200F-xx-PF-NGx (1200 A) UTS1200P-NGx-1200 (1200 A)	1000	

¹ Adjust the continuous current setting of the circuit breaker to match the specified rating.

• **Models EMX4i-0835B~EMX4i-1250B & EMX4i-0735C~EMX4i-1220C**

Suitable for use on a circuit capable of delivering up to the stated fault current, when protected by the specified circuit breaker or by fuses of the stated class and rating.

Fuses: These fuses were selected based on start current of 350% FLC for 30 seconds.

Circuit breakers: Select one of the specified circuit breakers according to the starter's current rating in the application.

@480 VAC				
Model	Nominal rating (A) 350%, 30 s	Fault current rating	Circuit breaker (rating, A)	Fuse rating (A, max) Class L
EMX4i-0835B	565	65 kA	R2CB-600A-600F-xx-HF-FTU (600 A)	1350
			R2CB-800A-800F-xx-HF-NGx (800 A)	
			R2CB-1200A-1200F-xx-HF-NGx (1200 A)	
			UTS600H-xxU-600 (600A)	
			UTS800H-NGx-800 (800A)	
			UTS1200H-NGx-1200 (1200A)	
	565	100 kA	R2CB-600A-600F-xx-LF-FTU (600 A)	
			R2CB-800A-800F-xx-LF-NGx (800 A)	
			R2CB-1200A-1200F-xx-LF-NGx (1200 A)	
			UTS600L-xxU-600 (600A)	
			UTS800L-NGx-800 (800A)	
			UTS1200L-NGx-1200 (1200A)	

@480 VAC				
Model	Nominal rating (A) 350%, 30 s	Fault current rating	Circuit breaker (rating, A)	Fuse rating (A, max) Class L
EMX4i-0940B	638	65 kA	R2CB-600A-600F-xx-HF-FTU (600 A)	1350
			R2CB-800A-800F-xx-HF-NGx (800 A)	
			R2CB-1200A-1200F-xx-HF-NGx (1200 A)	
			UTS600H-xxU-600 (600A)	
			UTS800H-NGx-800 (800A)	
	UTS1200H-NGx-1200 (1200A)			
	638	100 kA	R2CB-600A-600F-xx-LF-FTU (600 A)	
			R2CB-800A-800F-xx-LF-NGx (800 A)	
			R2CB-1200A-1200F-xx-LF-NGx (1200 A)	
			UTS600L-xxU-600 (600A)	
UTS800L-NGx-800 (800A)				
UTS1200L-NGx-1200 (1200A)				
EMX4i-1070B	854	65 kA	R2CB-600A-600F-xx-HF-FTU (600 A)	1350
			R2CB-800A-800F-xx-HF-NGx (800 A)	
			R2CB-1200A-1200F-xx-HF-NGx (1200 A)	
			UTS600H-xxU-600 (600A)	
			UTS800H-NGx-800 (800A)	
UTS1200H-NGx-1200 (1200A)				

@480 VAC				
Model	Nominal rating (A) 350%, 30 s	Fault current rating	Circuit breaker (rating, A)	Fuse rating (A, max) Class L
			R2CB-600A-600F-xx-LF-FTU (600 A)	
			R2CB-800A-800F-xx-LF-NGx (800 A)	
		100 kA	R2CB-1200A-1200F-xx-LF-NGx (1200 A)	
			UTS600L-xxU-600 (600A) UTS800L-NGx-800 (800A) UTS1200L-NGx-1200 (1200A)	
			HPD63B160 (1600A)	
		65 kA	R2CB-1200A-1200F-xx-HF-NGx (1200 A)	
			UTS1200H-NGx-1200 (1200A)	
EMX4i-1230B	1055		CPD63B160 (1600A)	
		100 kA	R2CB-1200A-1200F-xx-LF-NGx (1200 A)	
			UTS1200L-NGx-1200 (1200A)	
			HPD63B160 (1600A)	2500
		65 kA	R2CB-1200A-1200F-xx-HF-NGx (1200 A)	
			UTS1200H-NGx-1200 (1200A)	
EMX4i-1250B	1249		CPD63B160 (1600A)	
		100 kA	R2CB-1200A-1200F-xx-LF-NGx (1200 A)	
			UTS1200L-NGx-1200 (1200A)	

@480 VAC				
Model	Nominal rating (A) 350%, 30 s	Fault current rating	Circuit breaker (rating, A)	Fuse rating (A, max) Class L
			R2CB-600A-600F-xx-HF-FTU (600 A)	
			R2CB-800A-800F-xx-HF-NGx (800 A)	
		65 kA	R2CB-1200A-1200F-xx-HF-NGx (1200 A)	
			UTS600H-xxU-600 (600A)	
			UTS800H-NGx-800 (800A)	
			UTS1200H-NGx-1200 (1200A)	
EMX4i-0735C	621			1350
			R2CB-600A-600F-xx-LF-FTU (600 A)	
			R2CB-800A-800F-xx-LF-NGx (800 A)	
		100 kA	R2CB-1200A-1200F-xx-LF-NGx (1200 A)	
			UTS600L-xxU-600 (600A)	
			UTS800L-NGx-800 (800A)	
			UTS1200L-NGx-1200 (1200A)	
			R2CB-600A-600F-xx-HF-FTU (600 A)	
			R2CB-800A-800F-xx-HF-NGx (800 A)	
EMX4i-0830C	699	65 kA	R2CB-1200A-1200F-xx-HF-NGx (1200 A)	1350
			UTS600H-xxU-600 (600A)	
			UTS800H-NGx-800 (800A)	
			UTS1200H-NGx-1200 (1200A)	

@480 VAC				
Model	Nominal rating (A) 350%, 30 s	Fault current rating	Circuit breaker (rating, A)	Fuse rating (A, max) Class L
		100 kA	R2CB-600A-600F-xx-LF-FTU (600 A) R2CB-800A-800F-xx-LF-NGx (800 A) R2CB-1200A-1200F-xx-LF-NGx (1200 A) UTS600L-xxU-600 (600A) UTS800L-NGx-800 (800A) UTS1200L-NGx-1200 (1200A)	
		65 kA	R2CB-600A-600F-xx-HF-FTU (600 A) R2CB-800A-800F-xx-HF-NGx (800 A) R2CB-1200A-1200F-xx-HF-NGx (1200 A) UTS600H-xxU-600 (600A) UTS800H-NGx-800 (800A) UTS1200H-NGx-1200 (1200A)	
EMX4i-1025C	945			1350
		100 kA	R2CB-600A-600F-xx-LF-FTU (600 A) R2CB-800A-800F-xx-LF-NGx (800 A) R2CB-1200A-1200F-xx-LF-NGx (1200 A) UTS600L-xxU-600 (600A) UTS800L-NGx-800 (800A) UTS1200L-NGx-1200 (1200A)	
EMX4i-1170C	1178	65 kA	HPD63B160 (1600A) R2CB-1200A-1200F-xx-HF-NGx (1200 A) UTS1200H-NGx-1200 (1200A)	2500

SYSTEM DESIGN

@480 VAC				
Model	Nominal rating (A) 350%, 30 s	Fault current rating	Circuit breaker (rating, A)	Fuse rating (A, max) Class L
		100 kA	CPD63B160 (1600A) R2CB-1200A-1200F-xx-LF-N Gx (1200 A) UTS1200L-NGx-1200 (1200A)	
		65 kA	HPD63B160 (1600A) R2CB-1200A-1200F-xx-HF-NGx (1200 A) UTS1200H-NGx-1200 (1200A)	
EMX4i-1220C	1403	100 kA	CPD63B160 (1600A) R2CB-1200A-1200F-xx-LF-NGx (1200 A) UTS1200L-NGx-1200 (1200A)	

Model	Nominal rating (A) 350%, 30 s	@600 VAC		
		Fault current 50 kA	Fault current 65 kA	Fault current 100 kA
		Circuit breaker (rating, A max)	Circuit breaker (rating, A max)	Fuse rating (A, max) Class L
EMX4i-0835B	565	HPD63B160 (1600A) R2CB-1200A-1200F-xx- PF-NGx (1200 A) UTS1200P-xxx-1200 (1200A)	CPD63B160 (1600A)	
EMX4i-0940B	638	HPD63B160 (1600A) R2CB-1200A-1200F-xx- PF-NGx (1200 A) UTS1200P-xxx-1200 (1200A)	CPD63B160 (1600A)	1350
EMX4i-1070B	854	HPD63B160 (1600A) R2CB-1200A-1200F-xx- PF-NGx (1200 A) UTS1200P-xxx-1200 (1200A)	CPD63B160 (1600A)	
EMX4i-1230B	1055	HPD63B160 (1600A) R2CB-1200A-1200F-xx- PF-NGx (1200 A) UTS1200P-xxx-1200 (1200A)	CPD63B160 (1600A)	2500
EMX4i-1250B	1249	HPD63B160 (1600A) R2CB-1200A-1200F-xx- PF-NGx (1200 A) UTS1200P-xxx-1200 (1200A)	CPD63B160 (1600A)	
EMX4i-0735C	621	HPD63B160 (1600A) R2CB-1200A-1200F-xx- PF-NGx (1200 A) UTS1200P-xxx-1200 (1200A)	CPD63B160 (1600A)	1350

SYSTEM DESIGN

Model	Nominal rating (A) 350%, 30 s	@600 VAC		
		Fault current 50 kA	Fault current 65 kA	Fault current 100 kA
		Circuit breaker (rating, A max)	Circuit breaker (rating, A max)	Fuse rating (A, max) Class L
EMX4i-0830C	699	HPD63B160 (1600A) R2CB-1200A-1200F -xx- PF-NGx (1200 A) UTS1200P-xxx-1200 (1200A)	CPD63B160 (1600A)	
EMX4i-1025C	945	HPD63B160 (1600A) R2CB-1200A-1200F-xx- PF-NGx (1200 A) UTS1200P-xxx-1200 (1200A)	CPD63B160 (1600A)	
EMX4i-1170C	1178	HPD63B160 (1600A) R2CB-1200A-1200F-xx- PF-NGx (1200 A) UTS1200P-xxx-1200 (1200A)	CPD63B160 (1600A)	
EMX4i-1220C	1403	HPD63B160 (1600A) R2CB-1200A-1200F-xx- PF-NGx (1200 A) UTS1200P-xxx-1200 (1200A)	CPD63B160 (1600A)	2500

3.14 Specifications

Supply

Mains voltage (L1, L2, L3)

EMX4i-xxxxX-V5 200~525 VAC ($\pm 10\%$)

EMX4i-xxxxX-V7 380~690 VAC ($\pm 10\%$)

Control voltage (A1, A2, A3)

EMX4i-xxxxX-xx-C1 (A1, A2) 110~120 VAC (+10%/-15%), 600 mA

EMX4i-xxxxX-xx-C1 (A2, A3) 220~240 VAC (+10%/-15%), 600 mA

EMX4i-xxxxX-xx-C2 (A1, A2) 24 VAC/VDC ($\pm 20\%$), 2.8 A

Mains frequency 50 Hz~60 Hz (± 5 Hz)

Rated insulation voltage 690 VAC

Rated impulse withstand voltage 6 kV

Form designation .. Bypassed or continuous, semiconductor motor starter form 1

Short circuit capability

Coordination with semiconductor fuses Type 2

Coordination with HRC fuses Type 1

Electromagnetic capability (compliant with EU Directive 2014/3/EU)

EMC Immunity IEC 60947-4-2

EMC emissions IEC 60947-4-2 Class B

Inputs

Input rating Active 24 VDC, 8 mA approx

Motor thermistor (B4, B5) Trip >3.6 k Ω , reset <1.6 k Ω

Outputs

Relay outputs 10 A @ 250 VAC resistive, 5A @ 250 VAC AC15 pf 0.3

Main contactor (33, 34) Normally open

Bypass contactor (03, 04) Normally open

Relay output A (41, 42, 44) Changeover

Relay output B (53, 54) Normally open

Analog output (21, 22)

Maximum load 600 Ω (12 VDC @ 20 mA)

Accuracy $\pm 5\%$

Environmental

Operating temperature	-10 °C~60 °C, above 40 °C with derating
Storage temperature	-25 °C~+ 60 °C
Operating altitude	0~1000 m, above 1000 m with derating
Humidity	5%~95% relative humidity
Pollution degree	Pollution degree 3
Vibration	IEC 60068-2-6
Protection	

EMX4i-0024B~EMX4i-0135B	IP20
EMX4i-0184B~EMX4i-1250B	IP00
EMX4i-0184E~EMX4i-0580E	IP00
EMX4i-0184E~EMX4i-0580E	IP00
EMX4i-0735C~EMX4i-1220C	IP00

Heat dissipation

During start	4.5 watts per ampere
During run (Bypassed)	
EMX4i-0024B~EMX4i-0052B	≤ 35 watts approx
EMX4i-0064B~EMX4i-0135B	≤ 50 watts approx
EMX4i-0184B~EMX4i-0250B	≤ 120 watts approx
EMX4i-0352B~EMX4i-0580B	≤ 140 watts approx
EMX4i-0835B~EMX4i-1250B	≤ 180 watts approx
EMX4i-0184E~EMX4i-0250E	≤ 120 watts approx
EMX4i-0352E~EMX4i-0580E	≤ 140 watts approx
During run (Non-bypassed)	
EMX4i 0735C~EMX4i-1220C	4.5 watts per ampere

Motor overload protection

The soft starter uses a standard overload curve for motor protection. Trip classes 5, 10, 15, 20, 30 are available.

Certification

CCC	GB 14048.6
CE	EN 60947-4-2
C-UL	CAN/CSA-C22.2 N° 60947-1-13, CAN/CSA-C22.2 N° 60947-4-2-14
UL	UL 60947-4-2
EMX4i-0024B~EMX4i-1250B	UL Listed
EMX4i-0184E~EMX4i-0580E	UL Listed
EMX4i-0735C~EMX4i-1220C	UL Listed

Marine

Lloyds	Lloyds Marine No 1 Specification
ABS	Steel Vessels Rules 2010

RCM	IEC 60947-4-2
-----	---------------

Operational life (internal bypass contacts)

..... 100 000 operations

3.15 Disposal instructions

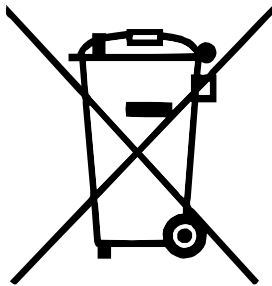

Equipment containing electrical components may not be disposed of together with domestic waste.

It must be collected separately as electrical and electronic waste according to local and currently valid legislation.

4. Installation



WARNING

Do not apply mains voltage to the starter until all wiring is complete.



WARNING

Always apply control voltage before (or with) mains voltage.

4.1 Command source

The EMX4i can be started and stopped via the digital inputs, remote keypad, communication network, smart card or scheduled auto-start/stop. The command source can be set via the setup tools, or using parameter 1A *Command Source*.

4.2 Setup procedure overview

1. Mount the soft starter (refer to *Physical installation* on page 20 for details).
2. Connect control wiring (see *Start/stop* on page 49 for details).
3. Apply control voltage to the starter.
4. Configure your application:
 1. Press ► to open the menu.
 2. Press ► to open the Quick Setup menu.
 3. Scroll through the list to find your application, then press ► to begin the configuration process (see *Quick setup* on page 65 for details).
5. If your application is not listed in Quick Setup:
 1. Press ◀ to return to the Menu.
 2. Use ▼ to scroll to Main Menu and press ►.
 3. Scroll to Motor Details and press ►, then press ▼ then ► to edit parameter 1B *Motor Full Load Current*.
 4. Set parameter 1B to match the motor's full load current (FLC).
 5. Press ► to save the setting.
6. Close the Menu by pressing ◀ repeatedly.
7. (Optional) Use the built-in control wiring and power assembly tools to check that the control wiring is connected correctly (refer to *Run simulation* on page 67).
8. Remove control power.
9. Connect the motor cables to starter output terminals 2/T1, 4/T2, 6/T3.
10. Connect mains supply cables to starter input terminals 1/L1, 3/L2, 5/L3 (refer to *Power terminations* on page 53).

The soft starter is now ready to control the motor.

4.3 Inputs



CAUTION

The digital inputs are powered by the soft starter. Do not apply external voltage to the digital input terminals.

NOTE



Cables to the digital inputs must be segregated from mains voltage and motor cabling.

Input terminals

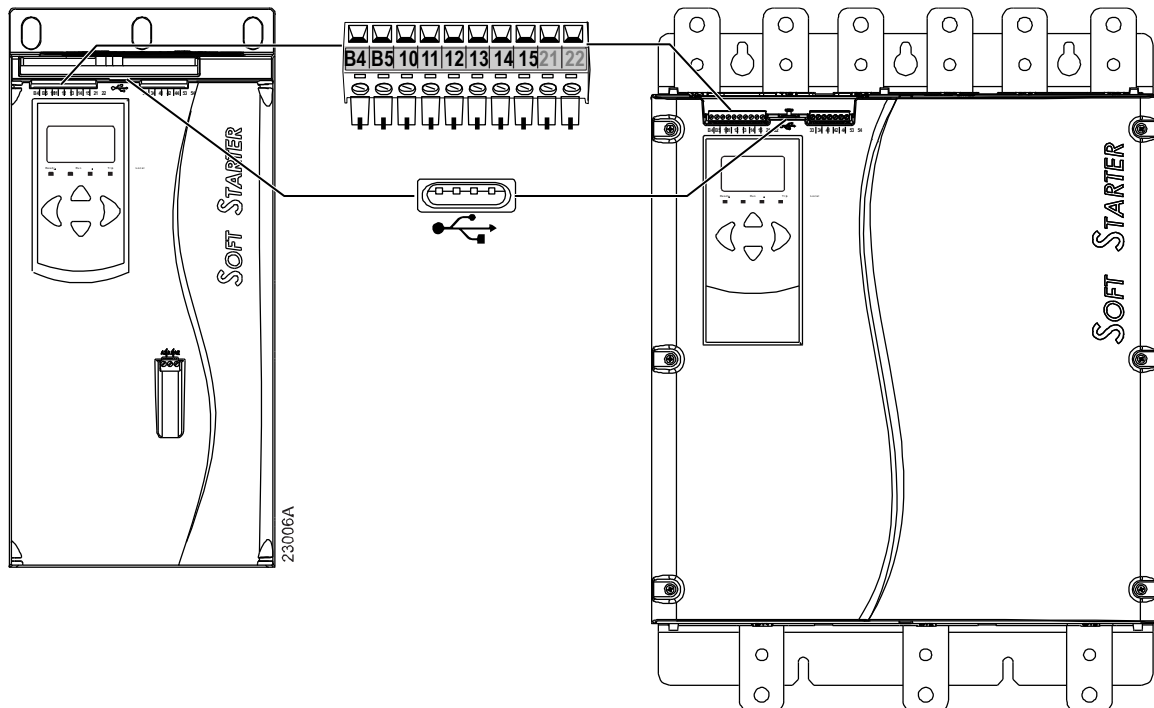

B4, B5 Motor thermistor input

10, 11 Reset input

11, 12 Start/Stop input

13, 14 Digital input A (default = Input Trip (N/O))

13, 15 Digital input B (default = Input Trip (N/O))

 USB-A port

Motor thermistor

Motor thermistors can be connected directly to the EMX4i. The soft starter will trip when the resistance of the thermistor circuit exceeds approximately 3.6 k Ω or falls below 20 Ω .

The thermistors must be wired in series. The thermistor circuit should be run in screened cable and must be electrically isolated from earth and all other power and control circuits.



NOTE

The thermistor input is disabled by default, but activates automatically when a thermistor is detected. If thermistors have previously been connected to the starter but are no longer required, use the Thermistor Reset function to disable the thermistor. Thermistor Reset is accessed via the Setup Tools.

Reset/starter disable

The reset input (10, 11) is normally closed by default. The soft starter will not perform a start if the reset input is open. The display will show 'Not Ready'. If the reset input opens while the EMX4i is running, the starter will remove power and allow the motor to coast to stop.



NOTE

The reset input can be configured for normally open or normally closed operation. Use parameter 71 *Reset/Enable Logic*.

Start/stop

The EMX4 requires two-wire control.

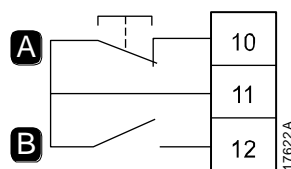

A	Reset
B	Start/Stop



WARNING

If the start input is closed when control voltage is applied, the starter will attempt to start.

Check that the Start/Stop input is open before applying control voltage.



NOTE

The starter will only accept commands from the digital inputs if parameter 1A *Command Source* is set to 'Digital Input'.

Programmable inputs

The programmable inputs (13, 14 and 13, 15) allow external equipment to control the starter.

The operation of the programmable inputs is controlled by parameters 7A~7H.

USB port

The USB port can be used to upload a configuration file, or download parameter settings and event log information from the starter. Refer to *USB save and load* on page 68 for details.

4.4 Outputs

Output terminals

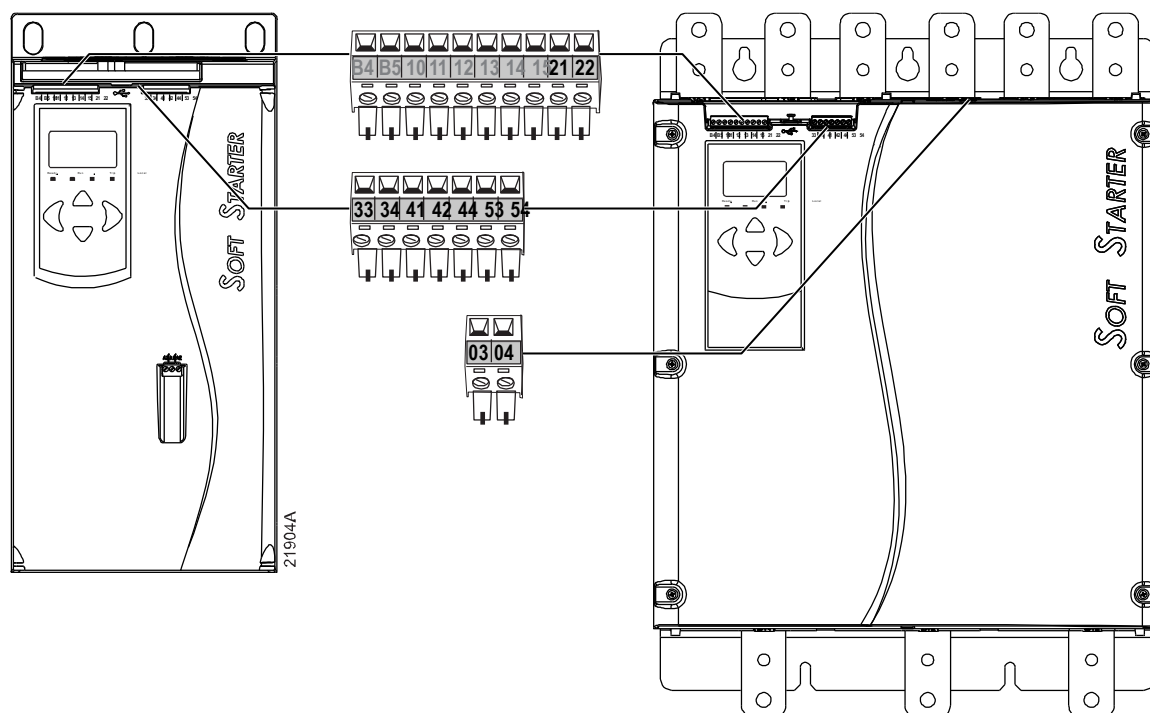

21, 22 Analog output

33, 34 Main contactor output

41, 42, 44 Relay output A (default = Run)

53, 54 Relay output B (default = Run)

03, 04 Bypass contactor output

Analog output

The starter has an analog output, which can be connected to associated equipment to monitor motor performance.

The operation of the analog output is controlled by parameters 9A~9D.

Main contactor output

The main contactor output (33, 34) closes as soon as the soft starter receives a start command and remains closed while the soft starter is controlling the motor (until the motor starts a coast to stop, or until the end of a soft stop). The main contactor output will also open if the soft starter trips.

The main contactor output can also be used to control a shunt trip circuit breaker.



NOTE

Use parameter 20H *Shunt Trip Mode* to configure the soft starter for use with a main contactor or circuit breaker.

- For use with a main contactor, use the default setting of 'Disable'
- For use with a circuit breaker, set 20H to 'Enable'

Soft starter installed with main contactor

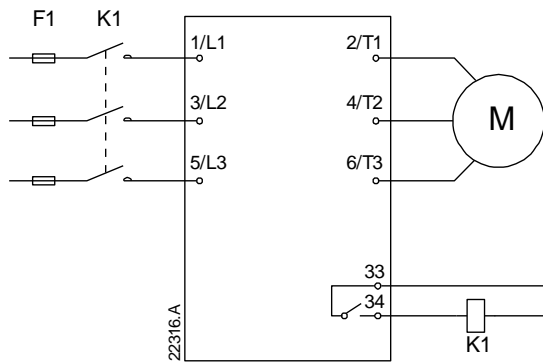

Soft starter installed with a shunt relay and circuit breaker

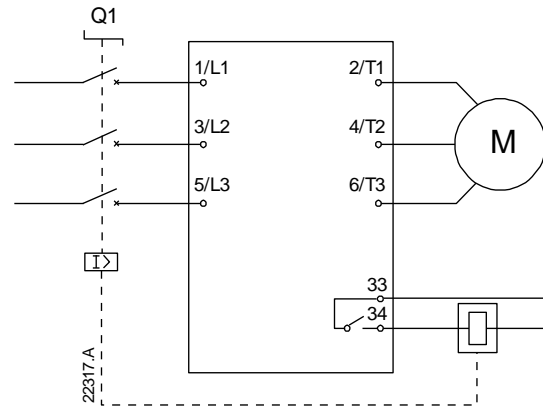

F1 Fuses

K1 Main contactor

Q1 Circuit breaker



CAUTION

Some contactor coils are unsuitable for direct switching with PCB mount relays. Only install the same coil type when replacing contactors.

Bypass contactor output

The bypass contactor output (03, 04) closes when the soft start is complete (when the starting current falls below 120% of the programmed motor full load current) and remains closed until the beginning of a stop (either soft stop or coast to stop).



NOTE

This output is only available on models EMX4i-0184E~EMX4i-0580E and EMX4i-0735C~EMX4i-1220C.



NOTE

If a non-bypassed soft starter is installed with an external bypass contactor, the soft starter's current rating changes. Enable parameter 20G *External Bypass* to increase the maximum current rating and adjust the soft starter's thermal model.

Programmable outputs

The programmable outputs (41, 42, 44 and 53, 54) can report the status of the starter, or can be used to control associated equipment.

The operation of the programmable outputs is controlled by parameters 8A~8F.

4.5 Control voltage

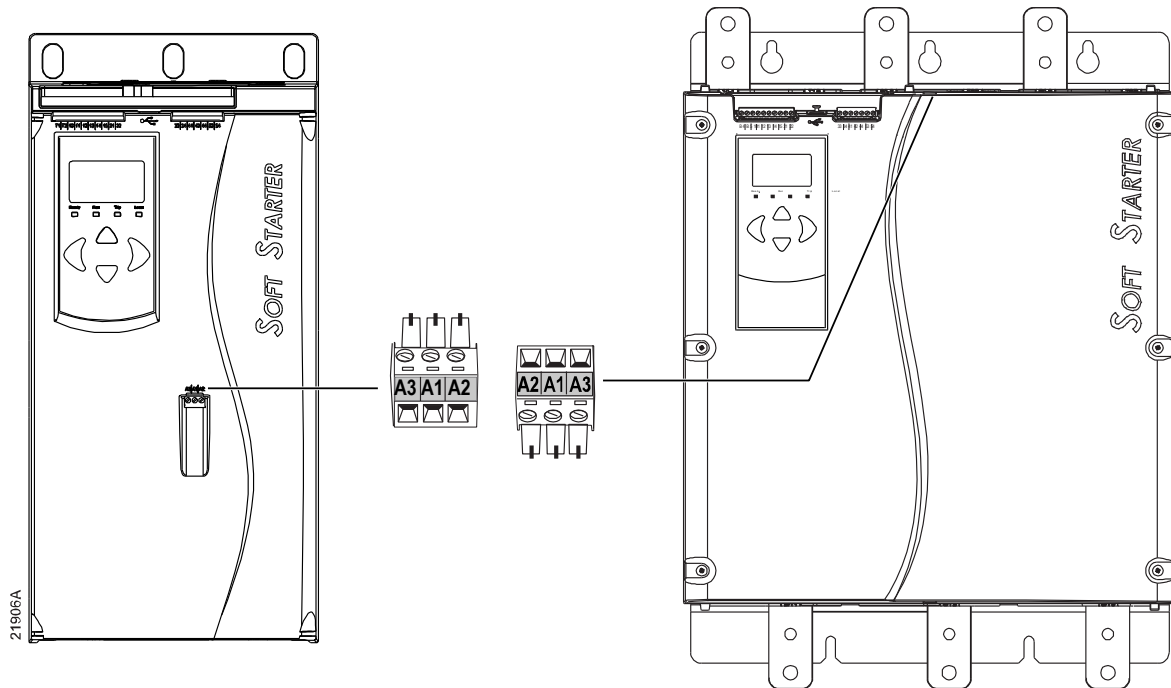

- EMX4i-xxxxX-xx-C1 (110~120 VAC): A1, A2
- EMX4i-xxxxX-xx-C1 (220~240 VAC): A2, A3
- EMX4i-xxxxX-xx-C2 (24 VAC/VDC): A1, A2

Install supplementary or branch overcurrent protection on the control circuit supply (A1, A2, A3), in accordance with the electrical code applicable at the installation location.

4.6 Power terminations

For models EMX4i-0024B~EMX4i-0580B and EMX4i-0184E~EMX4i-0580E, the power input and output terminals are at the bottom of the unit. For models EMX4i-0835B~EMX4i-1250B and EMX4i-0735C~EMX4i-1220C the power input is at the top and the output is at the bottom.

EMX4i-0024B~ EMX4i-0135B	EMX4i-0184B~ EMX4i-0580B	EMX4i-0835B~ EMX4i-1250B	EMX4i-0735C~ EMX4i-1220C
&			
EMX4i-0184E~ EMX4i-0580E			

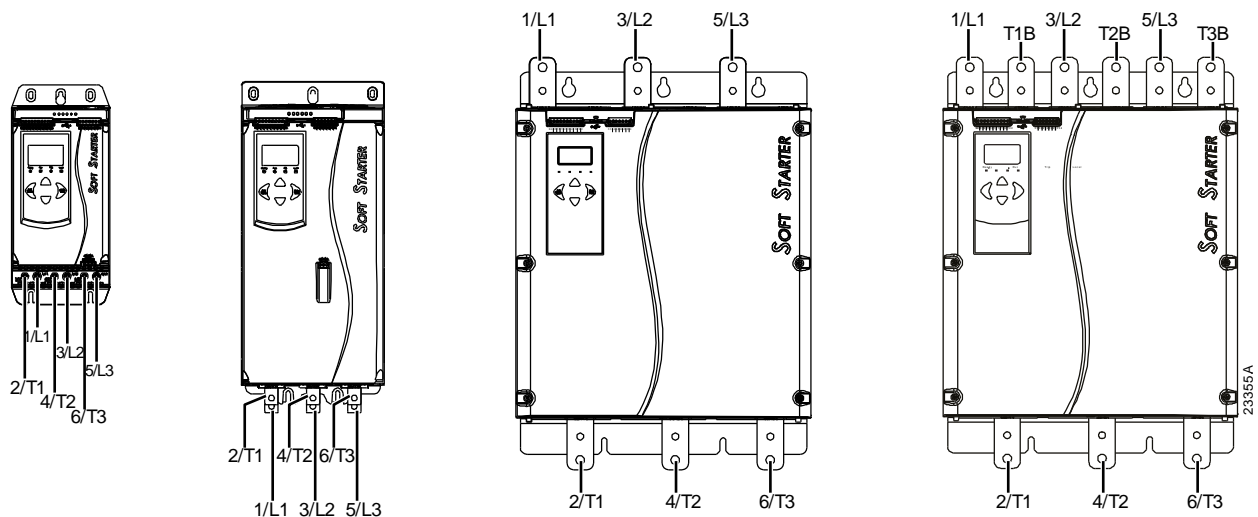

- Models EMX4i-0024B~EMX4i-0135B use cage clamps. Use only copper stranded or solid conductors, rated for 75 °C or higher.
- Models EMX4i-0184B~EMX4i-0580B /EMX4i-0184E~EMX4i-0580E use busbars at the bottom of the unit. Use copper or aluminium conductors, stranded or solid, rated for 60 °C/75 °C.
- Models EMX4i-0835B~EMX4i-1250B/EMX4i-0735C~EMX4i-1220C use busbars. Input terminals are at the top of the unit and output terminals are at the bottom.
- Models EMX4i-0735C~EMX4i-1220C have dedicated bypass terminals, if the soft starter will be installed with an external bypass contactor. The bypass busbars are at the top of the unit and are labelled T1B, T2B, T3B.

INSTALLATION

EMX4i-0024B~EMX4i-0135B

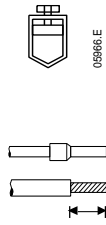

Cable size:

6-70 mm² (AWG 10-2/0)

Torque: 4 Nm (2.9 ft-lb)

14 mm (0.55 inch)

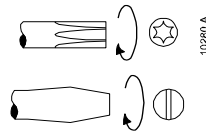

Torx T20 x 150

Flat 7 mm x 150

<p>EMX4i-0184B~ EMX4i-0250B & EMX4i-0184E~ EMX4i-0250E</p>	<p>EMX4i-0352B~ EMX4i-0580B & EMX4i-0352E~ EMX4i-0580E</p>	<p>EMX4i-0835B~ EMX4i-1250B & EMX4i-0735C~ EMX4i-1220C</p>
---	---	---

19 Nm (14.0 ft-lb)

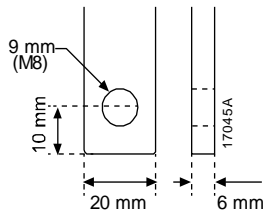

66 Nm (49.0 ft-lb)

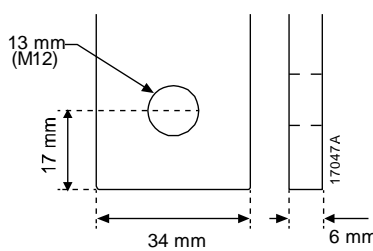

66 Nm (49.0 ft-lb)

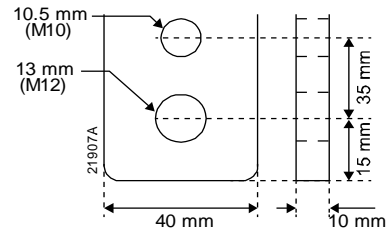

NOTE

If the installation requires large diameter cables, it is possible to complete each termination with two smaller cables, one on each side of the busbar.



NOTE

When connecting power terminations, clean the surface contact area thoroughly (using an emery cloth or stainless steel brush) and use an appropriate jointing compound to prevent corrosion.

Wiring connectors

Select a connector according to the wire size, material and your application requirements.

- **Models EMX4i-0024B~EMX4i-0580B**

A compression connector is recommended for models EMX4i-0184B to EMX4i-0580B. The recommended crimping tool is TBM8-750.

Model	Example connector – aluminium cable	Example connector – copper cable
EMX4i-0184B	61162	60150
EMX4i-0200B	61165	60156
EMX4i-0229B	61171	60165
EMX4i-0250B		
EMX4i-0352B	61162	60150
EMX4i-0397B	61165	60156
EMX4i-0410B		60162
EMX4i-0550B	61178	60171
EMX4i-0580B		

- **Models EMX4i-0835B~EMX4i-1250B & EMX4i-0735C~EMX4i-1220C**

A terminal lug is recommended for models EMX4i-0835B~EMX4i-1250B and EMX4i-0735C~EMX4i-1220C. The recommended lug is TCAL125.

- To use a lug, models EMX4i-0835B~EMX4i-1250B require busbar link 995-22395-00.
- To use a lug, models EMX4i-0735C~EMX4i-1220C require busbar link 995-22321-00 and 995-22395-00.

4.7 External bypass contactor

Models EMX4i-0735C~EMX4i-1220C have dedicated bypass terminals, which allow the soft starter's protection and monitoring functions to work even when the soft starter is externally bypassed.

Use the bypass contactor output (03, 04) to control the external bypass.



NOTE

If a non-bypassed soft starter is installed with an external bypass contactor, the soft starter's current rating changes. Enable parameter 20G *External Bypass* to increase the maximum current rating and adjust the soft starter's thermal model.

4.8 Motor connection

The EMX4i can be connected to the motor in-line or inside delta (also called three-wire and six-wire connection). When connecting in inside delta, enter the motor full load current (FLC) for parameter 1B. The EMX4i will automatically detect whether the motor is connected in-line or inside delta and will calculate the correct inside delta current level.



NOTE

If the starter is not correctly detecting the motor connection, use parameter 20F *Motor Connection*.

- **In-line installation, internally bypassed**

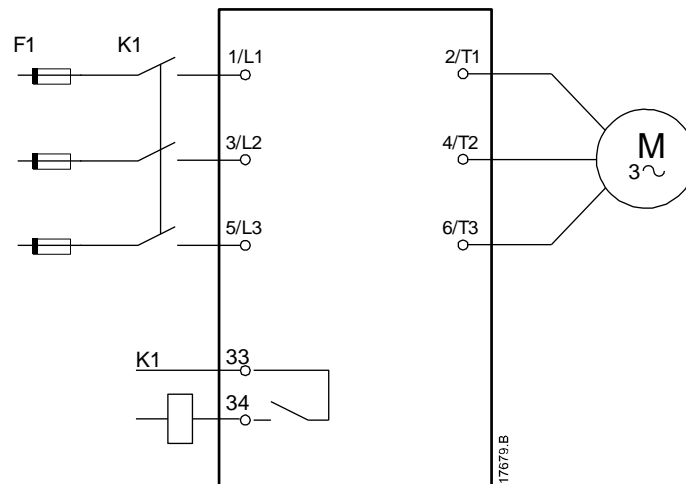

K1 Main contactor (strongly recommended)

F1 Fuses or circuit breaker

33, 34 Main contactor output

INSTALLATION

- In-line installation, externally bypassed**

Models EMX4i-0735C~EMX4i-1220C have dedicated bypass terminals, which allow the soft starter's protection and monitoring functions to work even when the soft starter is externally bypassed.

The bypass contactor must be connected to the bypass terminals and controlled by the soft starter's bypass contactor output (terminals 03, 04).

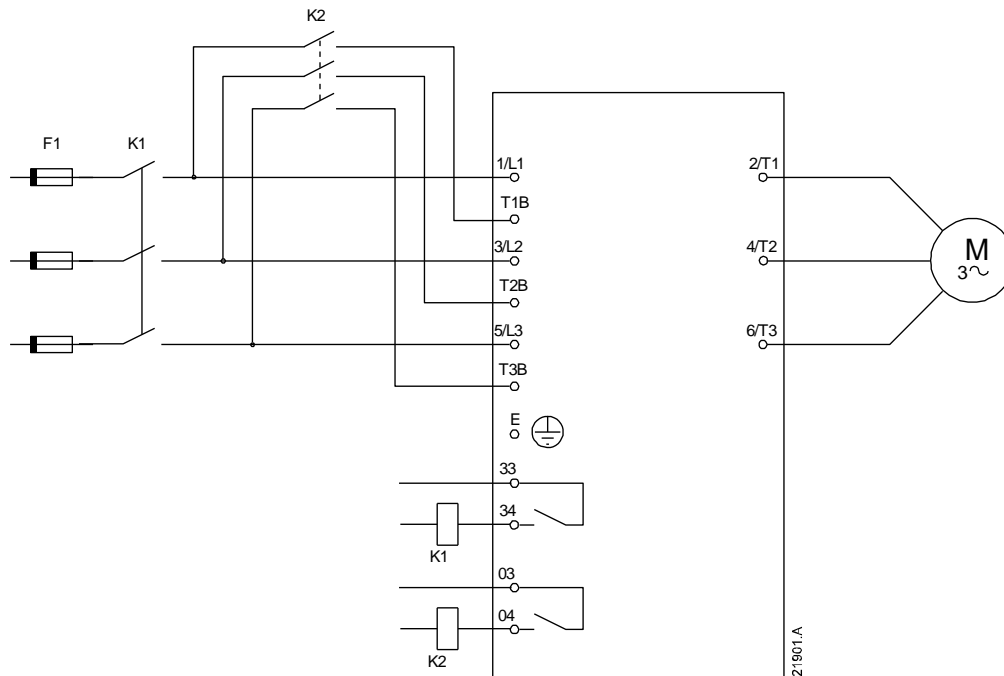

K1 Main contactor (strongly recommended)

K2 Bypass contactor

F1 Fuses or circuit breaker

33, 34 Main contactor output

03, 04 Bypass contactor output

• Inside delta installation, internally bypassed

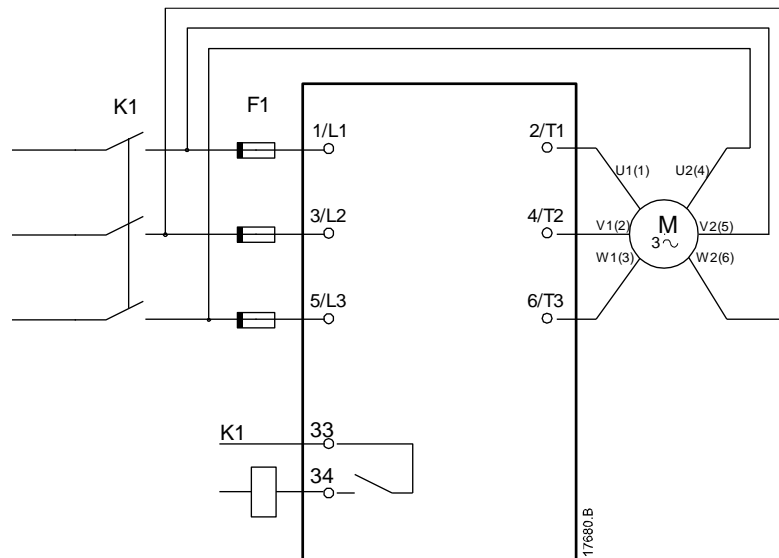

K1 Main contactor

F1 Fuses or circuit breaker

33, 34 Main contactor output



WARNING

When connecting the EMX4i in inside delta configuration, always install a main contactor or shunt trip circuit breaker.



NOTE

When connecting in inside delta, enter the motor full load current (FLC) for parameter 1B. The EMX4i will automatically detect whether the motor is connected in-line or inside delta and will calculate the correct inside delta current level.

- **Inside delta installation, externally bypassed**

Models EMX4i-0735C~EMX4i-1220C have dedicated bypass terminals, which allow the soft starter's protection and monitoring functions to work even when the soft starter is externally bypassed.

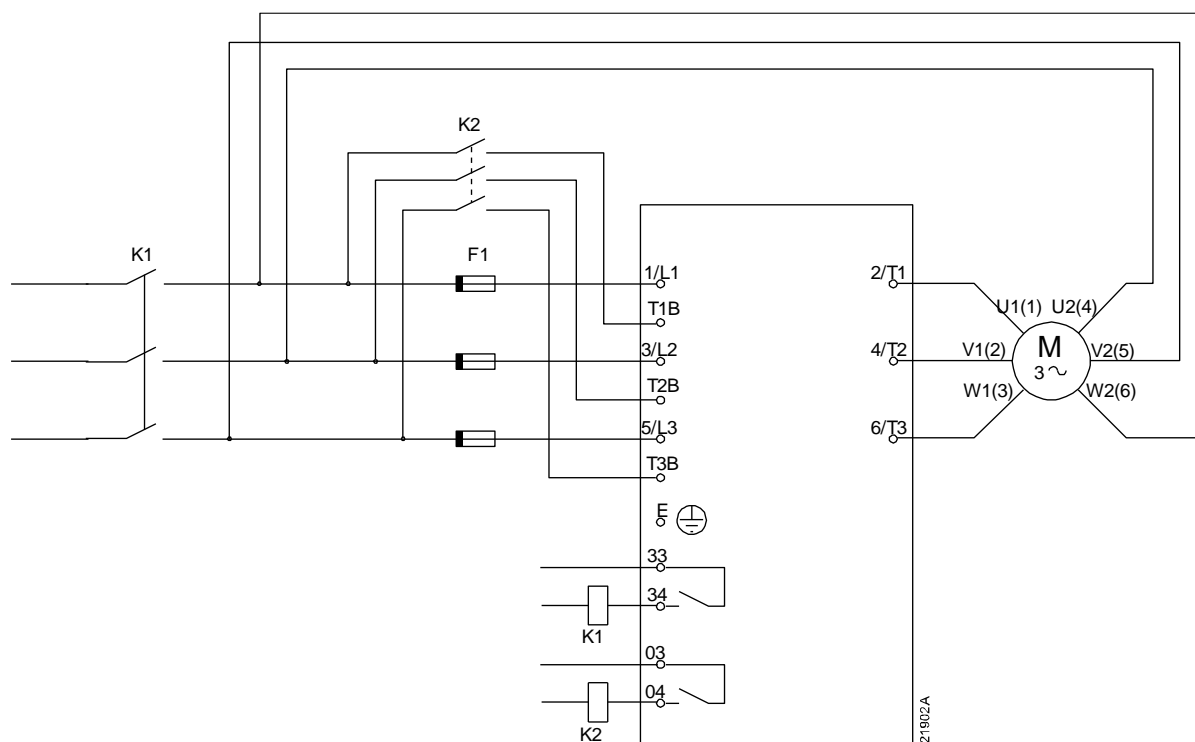

K1 Main contactor

K2 Bypass contactor (external)

F1 Fuses or circuit breaker

33, 34 Main contactor output

03, 04 Bypass contactor output

- **Models EMX4i-0184E~EMX4i-0580E**

Models EMX4i-0184E~EMX4i-0580E are supplied in complete panels. Contact your local supplier for drawings if required.

4.9 Earth terminations

Models EMX4i-0835B~EMX4i-1250B/EMX4i-0735C~EMX4i-1220C have earth terminals on each side of the starter, near the top back corner. Either earth point may be used.

Models EMX4i-0024B~EMX4i-0580B/EMX4i-0184E~EMX4i-0580E do not require a protective earth connection. All internal conductive parts are fully enclosed by a non-conductive outer case.

4.10 Typical installation

Internally bypassed installation

The soft starter is installed with a main contactor (AC-3 rated). Control voltage must be supplied from the input side of the contactor.

The main contactor is controlled by the main contactor output (33, 34).

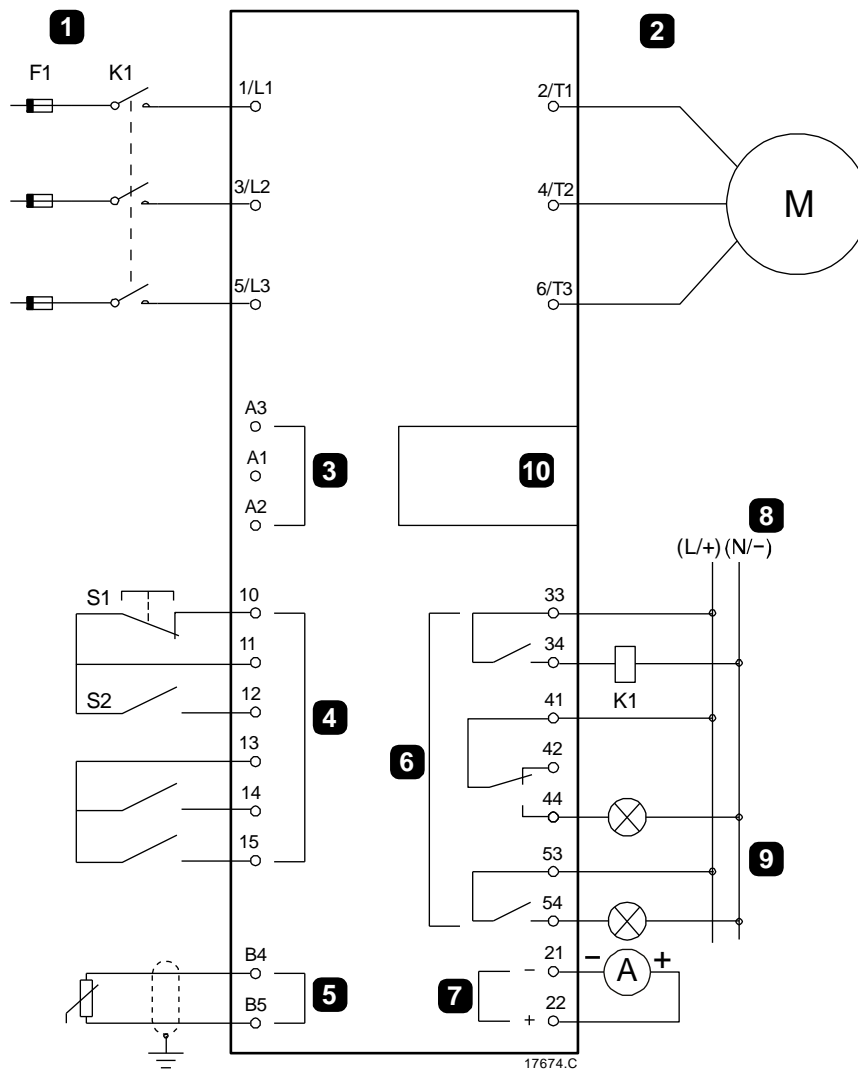

INSTALLATION

1	Three-phase supply	K1	Main contactor
2	Motor	F1	Fuses or circuit breaker
3	Control voltage (soft starter)	10, 11 (S1)	Reset
4	Digital inputs	11, 12 (S2)	Start/Stop
5	Motor thermistor input	13, 14	Digital input A (default = Input Trip (N/O))
6	Relay outputs	13, 15	Digital input B (default = Input Trip (N/O))
7	Analog output	B4, B5	Motor thermistor input
8	Control voltage (external equipment)	33, 34	Main contactor output
9	Pilot lamps	41, 42, 44	Relay output A (default = Run)
10	Communications / Smart card expansion port	53, 54	Relay output B (default = Run)
		21, 22	Analog output

INSTALLATION

1	Three-phase supply	K1	Main contactor
2	Motor	K2	Bypass contactor (external)
3	Control voltage (soft starter)	F1	Fuses or circuit breaker
4	Digital inputs	10, 11 (S1)	Reset
5	Motor thermistor input	11, 12 (S2)	Start/Stop
6	Relay outputs	13, 14	Digital input A (default = Input Trip (N/O))
7	Analog output	13, 15	Digital input B (default = Input Trip (N/O))
8	Control voltage (external equipment)	B4, B5	Motor thermistor input
9	Pilot lamps	33, 34	Main contactor output
10	Communications / Smart card expansion port	41, 42, 44	Relay output A (default = Run)
		53, 54	Relay output B (default = Run)
		03, 04	Bypass contactor output
		21, 22	Analog output

4.11 Quick setup

The Quick Setup Menu makes it easy to configure the soft starter for common applications. The starter guides you through the most common installation parameters, and suggests a typical setting for the application. You can adjust each parameter to suit your exact requirements.

All other parameters remain at default values. To change other parameter values or review the default settings, use the menu (refer to *Parameter list* on page 102 for details).

Always set parameter 1B *Motor Full Load Current* to match the motor's nameplate full load current.

Application	Start Mode	Start Ramp Time (seconds)	Initial Current (%)	Current Limit (%)	Adaptive Start Profile	Stop Mode	Stop Time (seconds)	Adaptive Stop Profile
Pump Centrifugal	Adaptive Control	10	200	500	Early accel.	Adaptive Control	15	Late decel.
Pump bore	Adaptive Control	3	200	500	Early accel.	Adaptive Control	3	Late decel.
Pump Hydraulic	Constant Current	2	200	350	n/a	Coast to stop	n/a	n/a
Fan Damped	Constant Current	2	200	350	n/a	Coast to stop	n/a	n/a
Fan Undamped	Constant Current	2	200	450	n/a	Coast to stop	n/a	n/a
Compressor Screw	Constant Current	2	200	400	n/a	Coast to stop	n/a	n/a
Compressor Recip	Constant Current	2	200	450	n/a	Coast to stop	n/a	n/a
Conveyor	Constant Current	5	200	450	n/a	Coast to stop	n/a	n/a
Bow thruster	Constant Current	5	100	400	n/a	Coast to stop	n/a	n/a
Bandsaw	Constant Current	2	200	450	n/a	Coast to stop	n/a	n/a



NOTE

The Adaptive Start and Stop Profile settings only apply when using Adaptive Control. The settings are ignored for all other start and stop modes.

5. Setup tools

Setup Tools includes options to load or save parameters to a backup file, set the starter's network address, check the status of the inputs and outputs, reset the thermal models or test operation using the run simulation.

To access the Setup Tools, press ► to open the menu then select Setup Tools.

5.1 Set date and time

To set the date and time:

1. Press ► to open the menu then select Setup Tools.
2. Scroll to Set Date & Time.
3. Press the ► button to enter edit mode.
4. Press the ► and ◀ buttons to select which part of the date or time to edit.
5. Use the [▲] and [▼] buttons to change the value.
6. Press ► after the last digit to save the setting. When the action has been completed, the screen will briefly display a confirmation message, then return to the previous menu level.

5.2 Command source

The EMX4i can be started and stopped via the digital inputs, remote keypad, communication network, smart card or scheduled auto-start/stop. The command source can be set via the setup tools, or using parameter 1A *Command Source*.

If the remote keypad is installed, the **LOCAL/REMOTE** button provides shortcut access to the Command Source function in Setup Tools.

5.3 Commissioning

Commissioning lets the starter be started and stopped via the local keypad. Use the ▲ and ▼ buttons to select a function, then press ► to send the selected command to the starter. The available functions are:

- Quick stop (coast to stop)/Reset
- Start
- Stop

5.4 Run simulation

The run simulation simulates a motor starting, running and stopping to confirm that the soft starter and associated equipment have been installed correctly.



NOTE

The soft starter must be disconnected from mains voltage.
The simulation is only available when the soft starter is in Ready state.

To use the run simulation:

Press **▶** to open the menu then select Setup Tools.

1. Scroll to Run Simulation and press **▶**.

Run Simulation
Ready
Apply Start Signal

2. Apply a start command from the selected command source. The EMX4i simulates its pre-start checks and closes the main contactor relay. The Run LED flashes.

Run Simulation
Pre-Start Checks
MENU to Continue



NOTE

If mains voltage is connected, an error message is shown.

Run Simulation
ATTENTION!
Remove Mains Volts
MENU to Continue

3. Press **▶**. The starter simulates starting.

Run Simulation
Starting X:XXs
MENU to Continue

4. Press **▶**. The EMX4i simulates running.

Run Simulation
Running
Apply Stop Signal

5. Apply a stop command from the selected command source. The EMX4i simulates stopping. The Run LED flashes.

Run Simulation
Stopping X:XXs
MENU to Continue

6. Press **▶**. The Ready LED flashes and the main contactor relay opens.

Run Simulation
Stopped
MENU to Continue

7. Press **▶**. The EMX4i activates then deactivates each programmable output.

Run Simulation
Prog Relay A
On
MENU to Continue

8. Press **▶** to return to the setup tools.

5.5 Load/save settings

Load/save settings allows you to:

- Reset all parameters to factory default values
- Load parameter settings from an internal file
- Save the current parameter settings to an internal file

The internal file contains default values until a user file is saved.

To load or save parameter settings:

1. Press **▶** to open the menu then select Setup Tools.
2. Scroll to Load/Save Settings and press the **▶** button.
3. Scroll to the required function and press the **▶** button.
4. At the confirmation prompt, select No to cancel or Yes to confirm, then press **▶** to proceed.

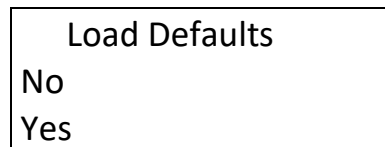
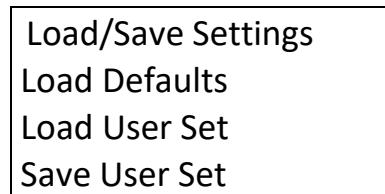

When the action has been completed, the screen will briefly display a confirmation message, then return to the previous menu level.

5.6 USB save and load

The USB save and load menu lets you:

- Save parameter settings and all event log entries to an external file (CSV format)
- Save parameter settings to an external file (proprietary format)
- Load parameter settings from a previously saved external file
- Load custom messages to display on the keypad when a programmable input is active



NOTE

The EMX4 supports FAT32 file systems. The EMX4's USB functions are not compatible with NTFS file systems.

Save and load procedure

1. Connect the external drive to the USB port.
2. Press ► to open the menu then select Setup Tools.
3. Scroll to USB Save & Load and press ►.
4. Scroll to the required function and press the ► button.
5. At the confirmation prompt, select No to cancel or Yes to confirm, then press ► to proceed.

USB Save & Load Save Params and Logs Save Master Params Load Master Params

Save Params and Logs No Yes

When the action has been completed, the screen will briefly display a confirmation message, then return to the previous menu level.

File locations and formats

Function	File location
Save Parameters and Logs	The starter will create a directory at the top level of the USB drive, named with the soft starter's serial number. The event log and parameter settings are saved as individual CSV files, and the soft starter's software and system information are saved to a text file.
Save Master Parameters	The starter will create a file called Master_Parameters.par, in the top level of the USB drive.
Load Master Parameters	The starter will load the file Master_Parameters.par from the top level of the USB drive. This file can be created or edited using the soft starter management software.
Load Custom Message	The starter will load the files Custom_Message_A.txt and Custom_Message_B.txt from the top level of the USB drive.

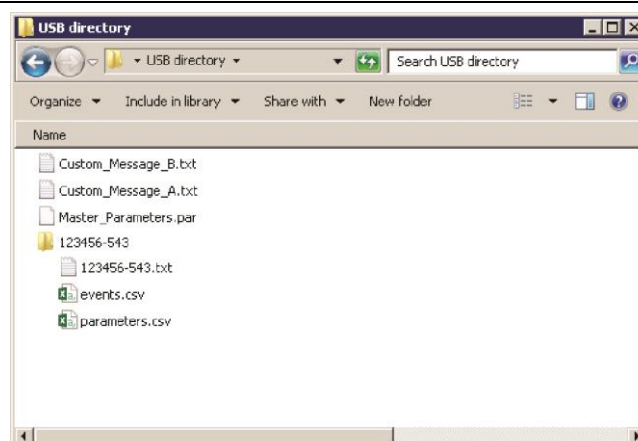

17788-A

5.7 Auto-start/stop

The EMX4i can be configured to automatically start and/or stop the motor at a particular time, or run it in cycles of a specified duration.

The Auto-Start/Stop option in Setup Tools gives quick access to the auto-start/stop parameters.

1. Press ► to open the menu then select Setup Tools.
2. Scroll to Auto-Start/Stop and press the ► button.
3. Scroll to the required function and press the ► button.
4. Adjust the settings as required:
 Press the ► and ◀ buttons to select which information to edit.
 Use the [▲] and [▼] buttons to change the value.
5. To save changes, press the ► button. The starter will confirm the changes.
 To cancel changes, press the ◀ button.

Auto-Start/Stop
Start/Stop Mode
Start/Stop Sunday
Start/Stop Monday

Start/Stop Sunday
Start/Stop Disable
Start Time: 00:00
Stop Time: 00:00

5.8 Network address

The soft starter can connect to an Ethernet network via an optional communication card. Options are available for EtherNet/IP, Modbus TCP and Profinet.

To use the EMX4i on an Ethernet network, separate addresses must be configured for:

- IP Address
- Gateway Address
- Subnet Mask

To set the network addresses:

1. Press **▶** to open the menu then select Setup Tools.
2. Scroll to Network Address and press the **▶** button.
3. Scroll to the required function and press the **▶** button.
4. The first digit of the address will be highlighted.
5. Use **◀** and **▶** to select which digit to alter. Use the **[▲]** and **[▼]** buttons to change the value.
6. Press **▶** after the last digit to save the setting.

Set IP Address
192.168.000.002

When the action has been completed, the screen will briefly display a confirmation message, then return to the previous menu level.



NOTE

The network address can also be set using parameters 12H~12S.

NOTE



To configure the EMX4i for use with other communication protocols, use parameters 12A~12G.

5.9 Digital I/O state

The top line of the screen shows the start/stop, reset and programmable inputs.

The bottom line of the screen shows the fixed main contactor output, then programmable outputs A and B.

Digital I/O State
 Inputs: 00000000
 Outputs: 00000000

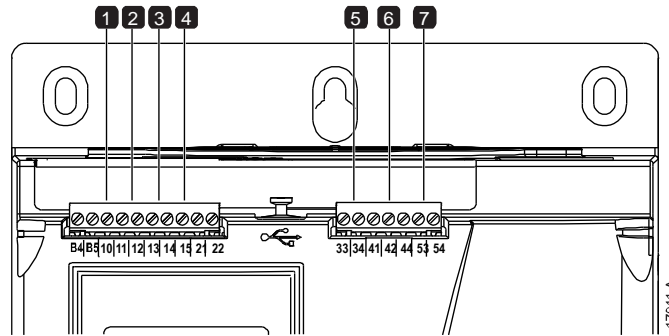

1	10, 11: Reset input
2	11, 12: Start/Stop input
3	13, 14: Digital input A
4	13, 15: Digital input B

5	33, 34: Main contactor output
6	41, 42, 44: Relay output A
7	53, 54: Relay output B

5.10 Analog I/O state

The top line of the screen shows the state of the motor thermistor input.

The bottom line of the screen shows the value of the analog output.

Analog I/O State
 Thermistor: 0
 4-20mA Output:
 04.0 mA

Thermistor input:

- S = Short
- H = Hot
- C = Cold
- O = Open

5.11 Serial number and rating

The top line of the screen shows the product name.

The middle line shows the unit's serial number.

The bottom line of the screen shows the model number.

Serial Number & Rating
 EMX4i
 123456-123
 0410-V5-S1-C1

5.12 Software versions

The software versions screen reports the version of each software component in the starter:

- user interface
- motor control
- remote keypad (if connected)
- parameter list
- bootloader
- expansion card (if fitted)



NOTE

Updated software, including alternative languages, can be loaded into the starter via the USB port if required. Contact your local supplier for further information.

5.13 Thermistor reset

The thermistor input is disabled by default, but activates automatically when a thermistor is detected. If thermistors have previously been connected to the starter but are no longer required, use the Thermistor Reset function to disable the thermistor.

5.14 Reset thermal model

The starter's thermal modelling software constantly monitors the motor's performance. This allows the starter to calculate the motor's temperature and ability to start successfully at any time.

The thermal model can be reset if required.



CAUTION

Resetting the motor overload will compromise protection and may compromise motor life. Only reset the motor overload in an emergency.

6. Logs

The Logs Menu provides information on events, trips and starter performance.

To access the Logs Menu on the local keypad, press ► to open the menu then select Logs. On the remote keypad, press **LOGS**.

6.1 Event logs

The event log stores details of the starter's most recent trips, warnings, and operations (including starts, stops and configuration changes).

Event 1 is the most recent and event 384 is the oldest stored event.



NOTE

The event log can be exported to an external file for analysis away from the starter. See *USB save and load* on page 68 for details.

6.2 Counters

The counters store statistics on the starter's operation:

- Hours run (lifetime and since counter last reset)
- Number of starts (lifetime and since counter last reset)
- Number of times the thermal model has been reset

To view the counters:

1. Open the Logs.
2. Scroll to 'Counters' and press ►.
3. Use the ▲ and ▼ buttons to scroll through the counters. Press ► to view details.
4. To reset a counter, press ► then use the ▲ and ▼ buttons to select Reset/Do Not Reset. Press ► to confirm the action.

To close the counter and return to the Logs, press ►.

6.3 QR code

The EMX4i can generate a QR code which allows a smartphone to display key information about the starter, including serial number, firmware versions and installed options, plus details of the starter's three most recent trips. This information can be useful when requesting assistance from your local supplier.



NOTE

You must install the soft starter support app in order to read the QR code. Contact your local supplier for further information.

7. Keypad and feedback

7.1 The keypad

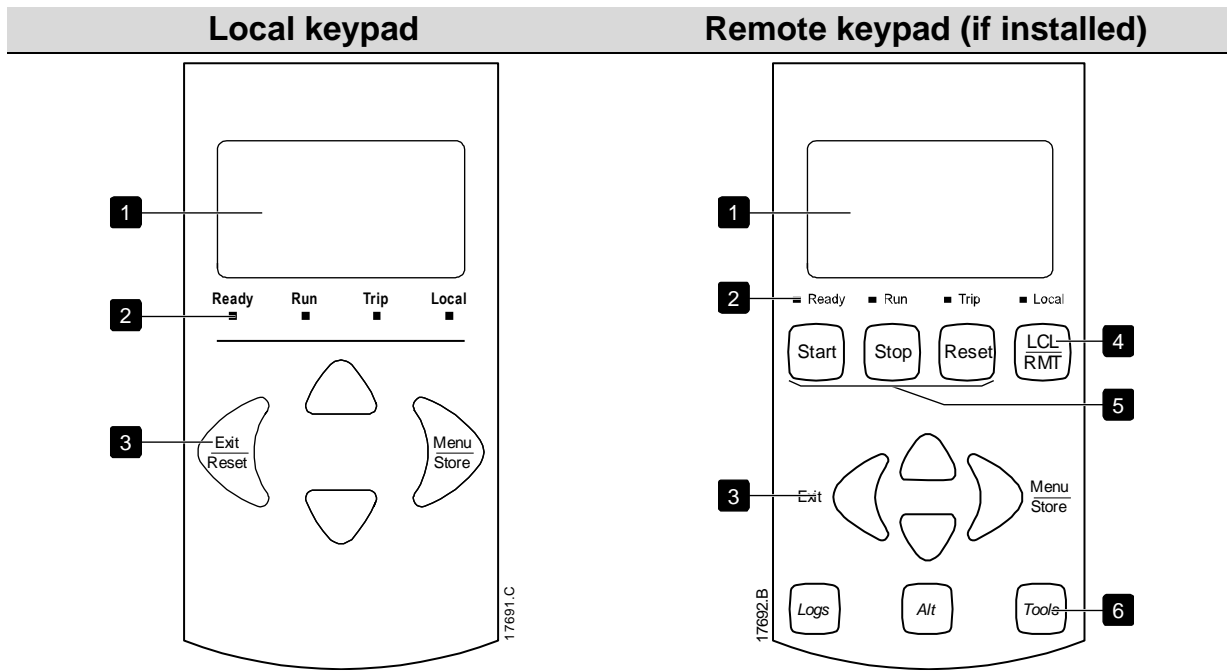

1 Four-line display for status and programming details.

2 Status LEDs

3 Menu navigation buttons:

◀: Exit the menu or parameter, or cancel a parameter change. On the local keypad, this button also resets a trip.

▶: Enter a menu or parameter, or save a parameter change.

▲ ▼: Scroll to the next or previous menu or parameter, change the setting of the current parameter or scroll through the status screens.

4 Shortcut to the command source menu in Setup Tools.

5 Soft starter local control buttons

6 Shortcut buttons for quick access to common tasks.

LOGS: Open the Logs Menu.

ALT: Select which graph to view, or pause/restart the graph (hold longer than 0.5 seconds)

TOOLS: Open the Setup Tools.

7.2 Remote keypad

The remote keypad can be used to control the soft starter if parameter 1A *Command Source* is set to 'Keypad'.

- If the remote keypad is not selected as the command source, the **START**, **STOP** and **RESET** buttons will have no effect.
- The menu navigation buttons and display on the remote keypad are always active.
- If a button is pressed on the starter's local keypad, the display on the remote keypad will update to match.



NOTE

The remote keypad can be safely connected or removed while the starter is running. It is not necessary to remove mains or control voltage.



NOTE

If parameter 1A *Command Source* is set to Keypad, removing the remote keypad will cause a trip.

7.3 Lighten/darken the display

The backlight on the display can be adjusted:

- to lighten the display, hold down the ◀ button and press the ▲ key
- to darken the display, hold down the ◀ button and press the ▼ key



NOTE

The local and remote keypads can be adjusted independently.

7.4 Starter status LEDs

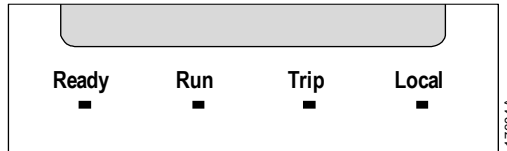

LED name	On	Flashing
Ready	The motor is stopped and the starter is ready to start.	The motor is stopped and the starter is not ready to start: <ul style="list-style-type: none"> • waiting for the <i>Restart Delay</i> (parameter 5P) • the thermal models indicate the starter and/or motor are too hot to start safely • the reset input (10, 11) is open
Run	The motor is in Run state (receiving full voltage).	The motor is starting or stopping.
Trip	The starter has tripped.	The starter is in Warning state.
Local	The starter is being controlled via a remote keypad.	–

If all LEDs are off, the starter is not receiving control voltage.

7.5 Displays

The keypad displays a wide range of performance information about the soft starter. To scroll through the feedback screens, press the ▲ and ▼ buttons.

Starter information

At power-up, the starter information screen shows details of the starter's rating, software versions and serial number.

Welcome 01.01/01.00/01.00 EMX4i-0069B-V5-S1-C1
--

Software versions: user interface, motor control, remote keypad
 Model code: current rating, mains voltage, frame size, control voltage
 (remote keypad software version is only displayed when a remote keypad is connected)

Starter status

69.0 A Running 69.0 A 415 V
--

Motor running current
 Starter state
 Parameters 10H *User Parameter 1* and 10I *User Parameter 2*

Current

The current monitoring screen shows real-time line current on each phase.

Phase Currents 000.0A 000.0A 000.0A
--

Last start information

The last start information screen shows details of the most recent successful start:

- start duration (seconds)
- maximum start current drawn (as a percentage of motor full load current)
- calculated rise in motor temperature

Last start 010s 350 % FLC ΔOL 5%

User configurable screen

The programmable screen can be configured to show the most important information for the particular application. Use parameters 10J ~ 10M to select which information to display.

Mains Frequency	59.7 Hz
Motor pf	0.95
Motor Power	37.0 kW
Motor Overload	85%

Date and time

The date/time screen shows the current system date and time (24 hour format). For details on setting the date and time, see *Set date and time* on page 66.

Performance graph

The performance graph provides a real-time display of operating performance. Use parameters 10B~10E to format the graph.

The display on the main keypad shows information for motor current.

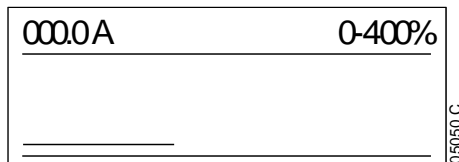

If a remote keypad is connected, press **ALT** to change the graph data. The graph can show:

- motor current
- motor overload
- motor pf
- analog input data from the smart card (if installed)

8. Operation

8.1 Start, stop and reset commands

The EMX4i can be started and stopped via the digital inputs, remote keypad, communication network, smart card or scheduled auto-start/stop. The command source can be set via the setup tools, or using parameter 1A *Command Source*.

- The EMX4i will only accept Start and Reset commands from the designated command source.
- The EMX4i will accept Stop commands from the designated command source, but can be forced to stop by opening the reset input, or by opening the start/stop input during an auto-start/stop cycle.
- The programmable input can be used to override the selected command source (refer to parameter 7A *Input A Function*).

8.2 Command override

The programmable input (13, 14) can be used to override the command source, for situations where the normal control mechanism has been lost. Set parameter 7A *Input A Function* to the alternative command source (eg 'Command Override: Keypad').

While the input is active, the starter will only accept commands from the selected override source. To restore control to the command source selected in parameter 1A *Command Source*, reopen the input.

8.3 Solid state overload protection

Overview

The EMX4i contains an advanced I²t electronic motor overload (OL) protection function. For optimal motor protection, the EMX4i has six standard NEMA style overload curves (in steps of five) available for use.

You can program separate overload classes for use during acceleration and during running. You can also disable the motor overload protection during acceleration or during normal running.

The EMX4i motor overload function also implements a NEMA-based current imbalance overload compensation, and adjustable exponential motor cooling.



CAUTION

If the EMX4i motor overload protection is disabled during any mode of operation, external motor overload protection must be provided to prevent motor damage and/or the risk of fire in the case of a motor overload.

Motor overload configuration

Use the following parameters to configure motor overload protection:

- 1B Motor Full Load Current
- 1F Motor Service Factor
- 1G Trip Class
- 5Q Starts per Hour

For more information, see the description of each parameter in 9 *Programmable parameters*.

The Motor Full Load Current (1B) and Motor Service Factor (1F) parameter settings define the load overload "pickup" point.

Example If the motor service factor is set to 1.00, the motor overload begins accumulating or incrementing when the measured motor current is >100% FLC (100% * 1.00). The overload will **not** trip if the load current is <100%.

Example If the motor service factor is set to 1.15, the overload starts accumulating content when the motor current >115% FLC (100% * 1.15). The overload will **not** trip if the measured motor current is <115% of rated FLC.

The overload trip classes are based on the trip time when operating at 600% of rated FLC.

OPERATION

a Class 10 overload trips in 10 seconds when the motor is operating at 600% rated FLC

a Class 20 overload trips in 20 seconds when the motor is operating at 600% rated FLC

Overload curves

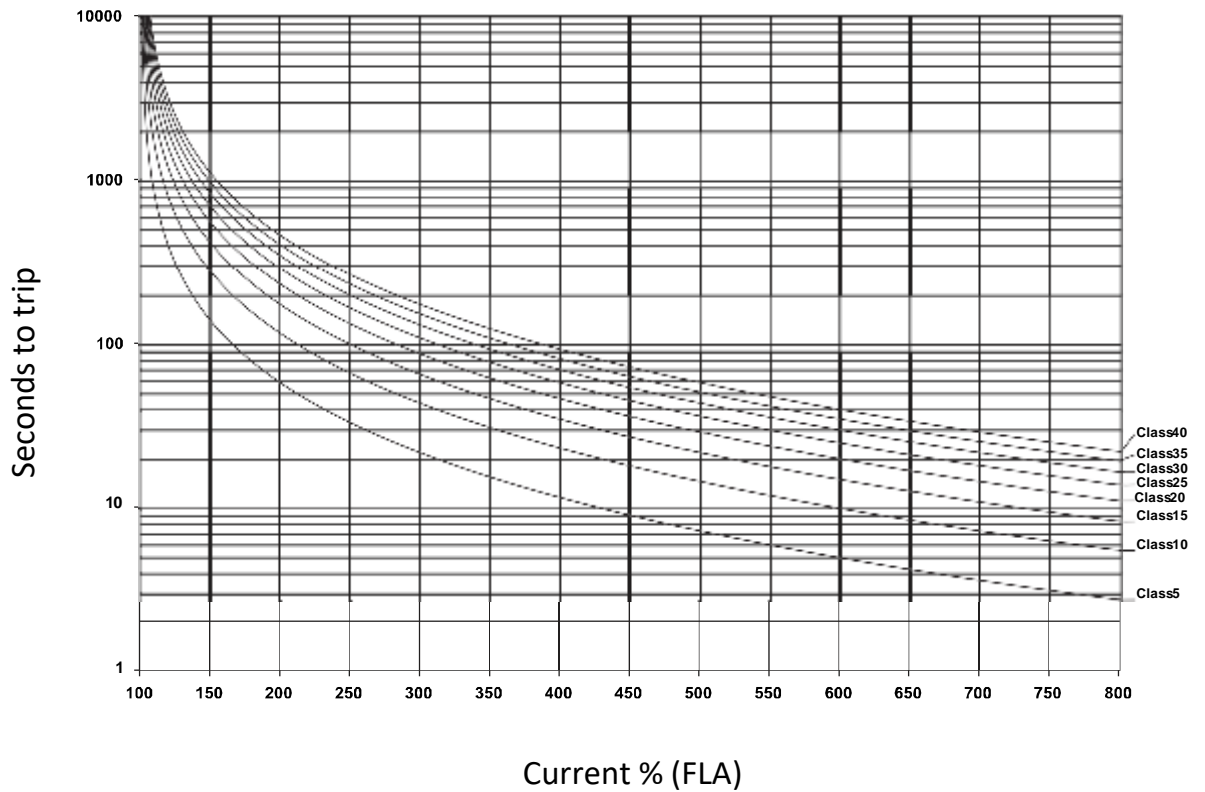

8.4 Auto-start/stop

The EMX4i can be configured to automatically start and/or stop the motor at a particular time, or run it in cycles of a specified duration.



NOTE

Start delay, restart delay and auto-reset delay all apply to auto-start operation.

Clock mode

The starter can start and/or stop the motor once per day.

For clock mode to operate:

- parameter 4A *Auto-Start/Stop Mode* must be set to 'Enable'
- parameter 1A *Command Source* must be set to 'Clock'
- the reset input must be closed
- the start input (11, 12) must be active. This allows the starter to be stopped via the digital inputs in an emergency.

Clock mode operation is controlled by parameters 4D ~ 4X.

Timer mode

The starter can automatically stop the motor after a specified run time, then restart it after a specified off (stopped) time. The starter will repeat the cycle while the start signal remains active.

For timer mode to operate:

- parameter 4A *Auto-Start/Stop Mode* must be set to 'Enable'
- parameter 1A *Command Source* must be set to 'Timer'
- the reset input must be closed
- the first start must be commanded by a start signal

Timer mode operation is controlled by parameters 4B ~ 4C.

8.5 PowerThrough

PowerThrough allows the soft starter to control the motor even if the soft starter is damaged on one phase. The starter will use two-phase control techniques to soft start and soft stop the motor.

PowerThrough does not support adaptive control soft starting or soft stopping. In PowerThrough, the soft starter will use constant current soft starting and timed voltage ramp soft stopping. If PowerThrough is enabled, parameters 2C and 2D must be set appropriately.



NOTE

The starter will trip on Lx-Tx Shorted on the first start attempt after control power is applied. PowerThrough will not operate if control power is cycled between starts.

- PowerThrough is only available with in-line installations. If the starter is installed inside delta, PowerThrough will not operate.
- PowerThrough remains active until '3-Phase Control Only' is reselected. While operating in PowerThrough, the trip LED will flash and the display will indicate '2 Phase – Damaged SCR'.



CAUTION

PowerThrough uses a two-phase soft start technology and additional care is required when sizing circuit breakers and protection. Contact your local supplier for assistance.

8.6 Emergency mode

Emergency mode allows the starter to run the motor and ignore trip conditions.

Emergency mode is controlled via a programmable input (input A 13, 14 or input B 13, 15) and parameter *7A Input A Function/7E Input B Function* must be set to 'Emergency Mode'. A closed circuit across 13, 14 activates emergency mode. When the starter receives a start command, it will continue to run until a stop command is received, ignoring all trips and warnings.

Emergency mode can be used in conjunction with any command source.



NOTE

Although emergency mode operation satisfies the functionality requirements of Fire Mode, AuCom does not recommend its use in situations that require testing and/or compliance with specific standards as it is not certified.



CAUTION

Continued use of emergency mode is not recommended. Emergency mode may compromise the starter and/or motor life as all protections and trips are disabled.

Using the starter in emergency mode will void the product warranty.

8.7 Auxiliary trip

An external trip circuit (such as a low pressure alarm switch for a pumping system) can be used to trip the soft starter and stop the motor. The external circuit is connected to a programmable input (input A 13, 14 or input B 13, 15). To control the behaviour of the trip, set the following parameters:

- Parameter *7A Input A Function*: select 'Input Trip (N/O)'.
• Parameter *7B Input A Trip*: set as required. For example, 'Run Only' limits the input trip to when the soft starter is running only.
- Parameter *7C Input A Trip Delay*: sets a delay between the input activating and the soft starter tripping.
- Parameter *7D Input A Initial Delay*: sets a delay before the soft starter monitors the state of the input, after the start signal. For example, a delay may be required to allow time for pipeline pressure to build up.
- Parameter *7J Input A Name*: select a name, eg 'Input A Trip' (optional).

8.8 Typical control methods

The requirements of an application differ between each installation, but the methods listed below are often a good starting point for common applications.

Application	Start Mode	Start Ramp Time (seconds)	Initial Current (%FLC)	Current Limit (%FLC)	Stop Mode	Stop Time (seconds)
Bow thruster	Constant Current	5	100	400	Coast to stop	n/a
Centrifuge (Separator)	Constant Current	1	200	450	Coast to stop	n/a
Chipper	Constant Current	1	200	450	Coast to stop	n/a
Compressor - reciprocating - loaded	Constant Current	1	200	450	Coast to stop	n/a
Compressor - reciprocating - unloaded	Constant Current	1	200	400	Coast to stop	n/a
Compressor - screw - loaded	Constant Current	1	200	400	Coast to stop	n/a
Compressor - screw - unloaded	Constant Current	1	200	350	Coast to stop	n/a
Conveyor - horizontal	Constant Current	5	200	400	TVR Soft Stop	10
Conveyor - inclined	Constant Current	2	200	450	Coast to stop	n/a
Conveyor - vertical (bucket)	Constant Current	2	200	450	Coast to stop	n/a
Crusher - cone	Constant Current	1	200	350	Coast to stop	n/a
Crusher - jaw	Constant Current	1	200	450	Coast to stop	n/a
Crusher - rotary	Constant Current	1	200	400	Coast to stop	n/a
Debarker	Constant Current	1	200	350	Coast to stop	n/a

Application	Start Mode	Start Ramp Time (seconds)	Initial Current (%FLC)	Current Limit (%FLC)	Stop Mode	Stop Time (seconds)
Fan - axial (damped)	Constant Current	1	200	350	Coast to stop	n/a
Fan - axial (undamped)	Constant Current	1	200	450	Coast to stop	n/a
Fan - centrifugal (damped)	Constant Current	1	200	350	Coast to stop	n/a
Fan - centrifugal (undamped)	Constant Current	1	200	450	Coast to stop	n/a
Fan - high pressure	Constant Current	1	200	450	Coast to stop	n/a
Mill - ball	Constant Current	1	200	450	Coast to stop	n/a
Mill - hammer	Constant Current	1	200	450	Coast to stop	n/a
Pump - bore	Adaptive Control (Early accel.)	3	n/a	500	Adaptive Control (Late decel.)	3
Pump - centrifugal	Adaptive Control (Early accel.)	10	n/a	500	Adaptive Control (Late decel.)	15
Pump - Hydraulic	Constant Current	2	200	350	Coast to stop	n/a
Pump - positive displacement	Adaptive Control (Const. accel.)	10	n/a	400	Adaptive Control (Const. decel.)	10
Pump - submersible	Adaptive Control (Early accel.)	5	n/a	500	Adaptive Control (Late decel.)	5
Saw - bandsaw	Constant Current	1	200	450	Coast to stop	n/a
Saw - circular	Constant Current	1	200	350	Coast to stop	n/a
Shredder	Constant Current	1	200	450	Coast to stop	n/a

8.9 Soft start methods

Constant current

Constant current is the traditional form of soft starting, which raises the current from zero to a specified level and keeps the current stable at that level until the motor has accelerated.

Constant current starting is ideal for applications where the start current must be kept below a particular level.

Constant current

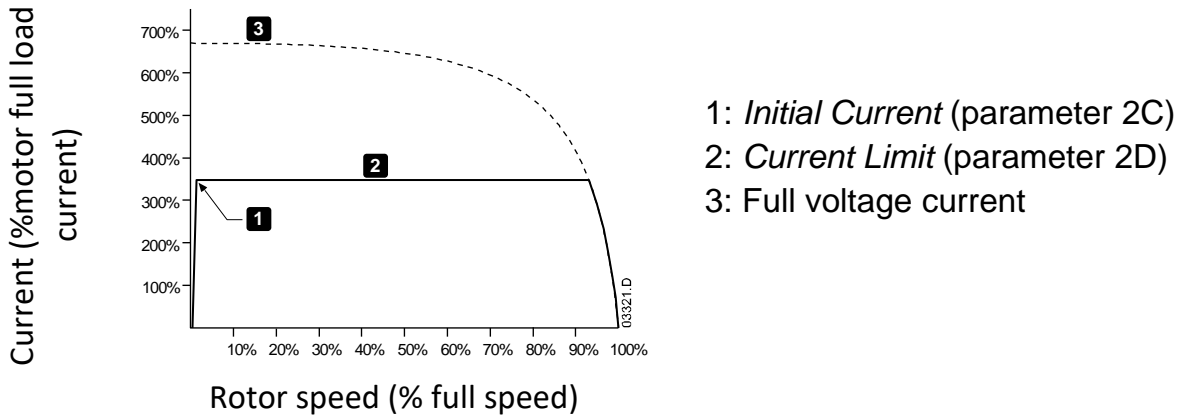

Constant current with current ramp

Current ramp soft starting raises the current from a specified starting level (1) to a maximum limit (3), over an extended period of time (2).

Current ramp starting can be useful for applications where:

- the load can vary between starts (for example a conveyor which may start loaded or unloaded). Set the initial current (parameter 2C) to a level that will start the motor with a light load, and the current limit (parameter 2D) to a level that will start the motor with a heavy load.
- the load breaks away easily, but starting time needs to be extended (for example a centrifugal pump where pipeline pressure needs to build up slowly).
- the electricity supply is limited (for example a generator set), and a slower application of load will allow greater time for the supply to respond.

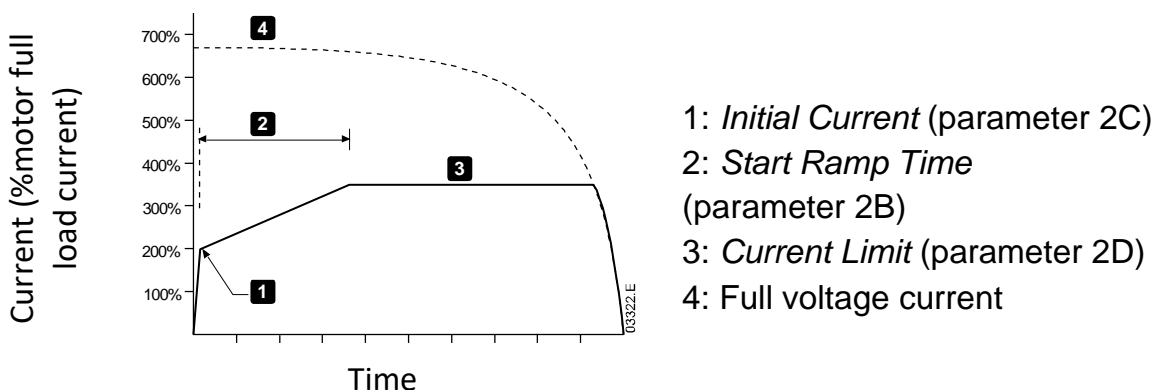

Constant current with kickstart

Kickstart provides a short boost of extra torque at the beginning of a start, and can be used in conjunction with current ramp or constant current starting.

Kickstart can be useful to help start loads that require high breakaway torque but then accelerate easily (for example helical rotor pumps).

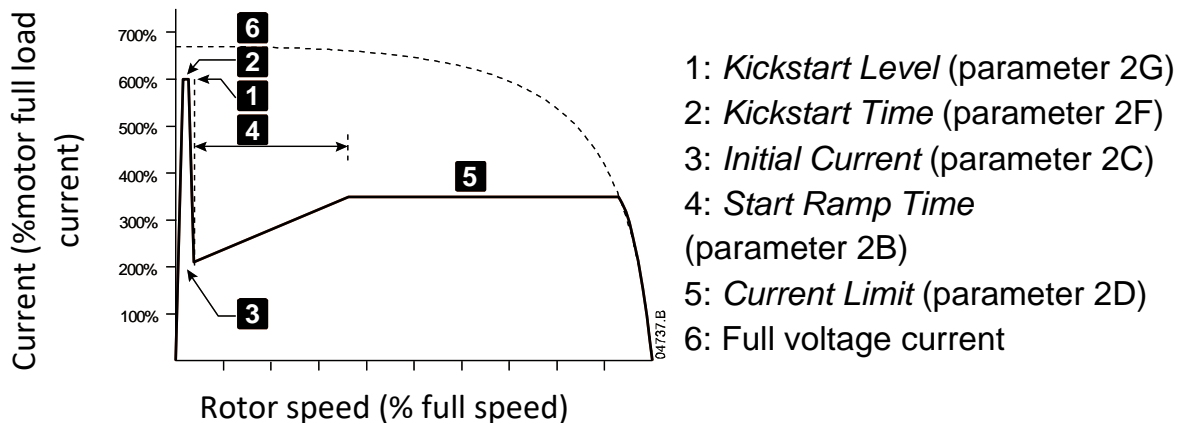

Timed voltage ramp

Timed voltage ramp (TVR) soft starting ramps the application of voltage to the motor over a defined time period. The voltage ramp reduces the initial starting torque and slows the motor's rate of acceleration.

TVR starting can be useful for applications where multiple motors of different sizes are connected in parallel, and/or the loads are not mechanically linked.



NOTE

TVR soft starting is not suitable for high inertia loads (such as fans), which require a high level of voltage to accelerate the load.



NOTE

For multiple motors of the same sizes, and/or mechanically coupled loads, use constant current starting.

For a timed voltage ramp start, the following are typical values and can be adjusted to suit your specific application:

- Add the FLC value of all the connected motors. Use this combined value to set parameter 1B *Motor Full Load Current*. (Note that the combined value must not exceed the starter rating.)
- Set parameter 2C *Initial Current* to 100%, parameter 2D *Current Limit* to 500%, and set the ramp time as required (parameter 2B *Start Ramp Time*).

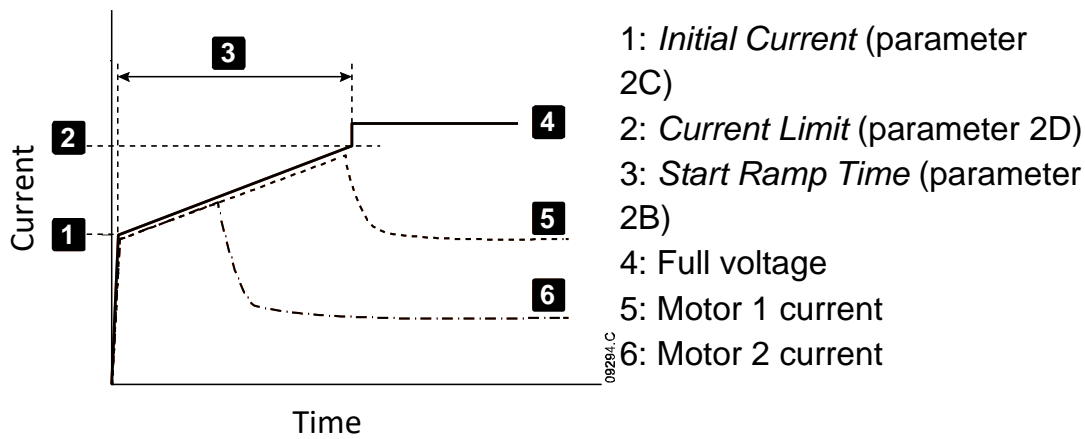

Adaptive control for starting

In an adaptive control soft start, the starter adjusts the current in order to start the motor within a specified time and using a selected acceleration profile.



NOTE

The starter will apply the current limit on all soft starts, including adaptive control. If the current limit is too low or the start ramp time (parameter 2B) is too short, the motor may not start successfully.

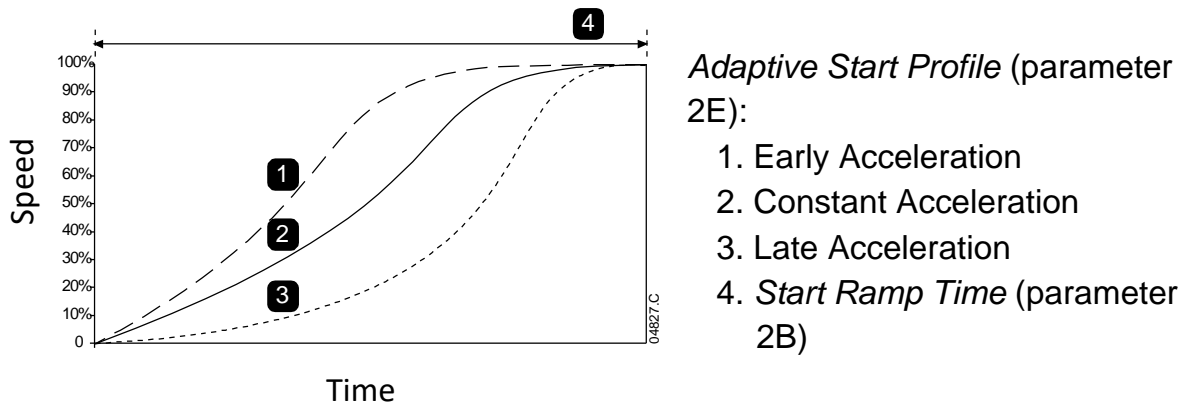

• **Fine-tuning adaptive control**

If the motor does not start or stop smoothly, adjust the adaptive control gain (parameter 2L). The gain setting determines how much the starter will adjust future adaptive control starts and stops, based on information from the previous start. The gain setting affects both starting and stopping performance.

- If the motor accelerates or decelerates too quickly at the end of a start or stop, increase the gain setting by 5%~10%.
- If the motor speed fluctuates during starting or stopping, decrease the gain setting slightly.

**NOTE**

The starter tunes Adaptive Control to match the motor. Changing the following parameters will reset Adaptive Control and the first start/stop cycle will use constant current start/timed voltage ramp stop: 1B *Motor Full Load Current*, 2D *Current Limit*, 2L *Adaptive Control Gain*.

8.10 Stop methods

Coast to stop

Coast to stop lets the motor slow at its natural rate, with no control from the soft starter. The time required to stop will depend on the type of load.

Timed voltage ramp soft stop

Timed voltage ramp stopping reduces the voltage to the motor gradually over a defined time. This can extend the stopping time of the motor and may avoid transients on generator set supplies.

**NOTE**

The load may continue to run after the stop ramp is complete.

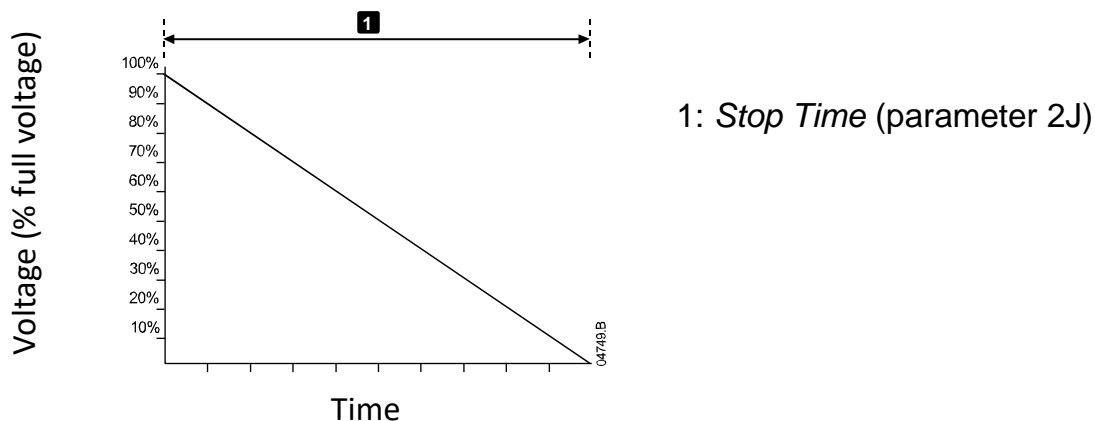

Adaptive control for stopping

In an adaptive control soft stop, the starter controls the current in order to stop the motor within a specified time and using a selected deceleration profile. Adaptive control can be useful in extending the stopping time of low inertia loads.

If adaptive control is selected, the first soft stop will use timed voltage ramp. This allows the starter to learn the characteristics of the connected motor. This motor data is used by the starter during subsequent adaptive control stops.

**NOTE**

Adaptive control does not actively slow the motor down and will not stop the motor faster than a coast to stop. To shorten the stopping time of high inertia loads, use brake.



CAUTION

Adaptive Control controls the motor's speed profile, within the programmed time limit. This may result in a higher level of current than traditional control methods.

If replacing a motor connected to a starter programmed for Adaptive Control starting or stopping, the starter will need to learn the characteristics of the new motor. Change the value of parameter 1B *Motor Full Load Current* or parameter 2L *Adaptive Control Gain* to initiate the re-learning process. The next start will use constant current and the next stop will use timed voltage ramp.

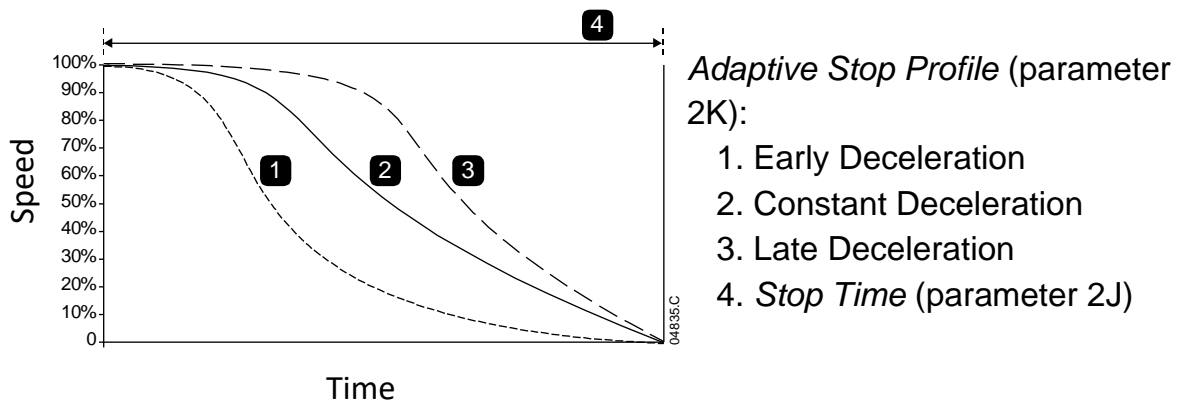

Adaptive Control is ideal for pumping applications, where it can minimise the damaging effects of fluid hammer. We recommend testing the three profiles to identify the best profile for the application.

Adaptive Stop Profile	Application
Late Deceleration	High head systems where even a small decrease in motor/pump speed results in a rapid transition between forward flow and reverse flow.
Constant Deceleration	Low to medium head, high flow applications where the fluid has high momentum.
Early Deceleration	Open pump systems where fluid must drain back through the pump without driving the pump in reverse.

DC brake

Brake reduces the time required to stop the motor.

During braking an increased noise level from the motor will be audible. This is a normal part of motor braking.



CAUTION

When using DC brake, the mains supply must be connected to the soft starter (input terminals L1, L2, L3) in positive phase sequence.

**CAUTION**

If the brake torque is set too high, the motor will stop before the end of the brake time and the motor will suffer unnecessary heating which could result in damage. Careful configuration is required to ensure safe operation of the starter and motor.

A high brake torque setting can result in peak currents up to motor DOL being drawn while the motor is stopping. Ensure protection fuses installed in the motor branch circuit are selected appropriately.

**CAUTION**

Brake operation causes the motor to heat faster than the rate calculated by the motor thermal model. If you are using brake, install a motor thermistor or allow sufficient restart delay (parameter 5P).

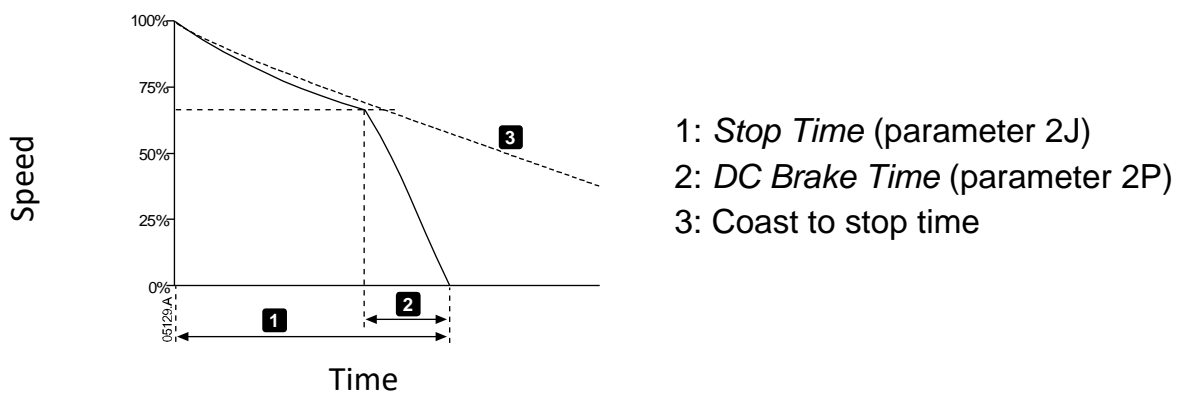
**Parameter settings:**

- Parameter 2I *Stop Mode*: set to 'DC Brake'.
- Parameter 2J *Stop Time*: This is the total braking time (1) and must be set sufficiently longer than the DC brake time (parameter 2P) to allow the pre-braking stage to reduce motor speed to approximately 65%. If the stop time is too short and the speed has not reduced sufficiently during the pre-braking phase, braking will not be successful and the motor will coast to stop after the stop time expires.
- Parameter 2O *DC Brake Torque*: set as required to slow the load. If set too low, the motor will not stop completely and will coast to stop after the end of the braking period.
- Parameter 2P *DC Brake Time*: Set Brake Time (parameter 2P) to approximately one quarter of the programmed Stop Time. This sets the time for the Full Brake stage (2).

Soft brake

For applications with high inertia and/or a variable load requiring the maximum possible braking torque, the starter can be configured for soft braking.

The starter uses a changeover relay to control forward run and braking contactors. While braking, the starter reverses the phase sequence to the motor and supplies reduced current, gently slowing the load.

When motor speed approaches zero, the zero speed sensor (A2) stops the soft starter and opens the braking contactor (K2).

Soft braking can be used with both the primary and secondary motor sets, and must be configured separately for each.

Parameter settings:

- Parameter 2I *Stop Mode*: set to 'Soft Brake'
- Parameter 2Q *Brake Current Limit*: set as required to slow the load
- Parameter 2R *Soft Brake Delay*: controls the time the soft starter will wait after a stop signal is received, before it begins to supply braking current to the motor. Set to allow time for K1 and K2 to switch.
- Parameter 7A *Input A Function*: set to 'Zero Speed Sensor'
- Parameter 8A *Relay A Function*: set to 'Soft Brake Relay'

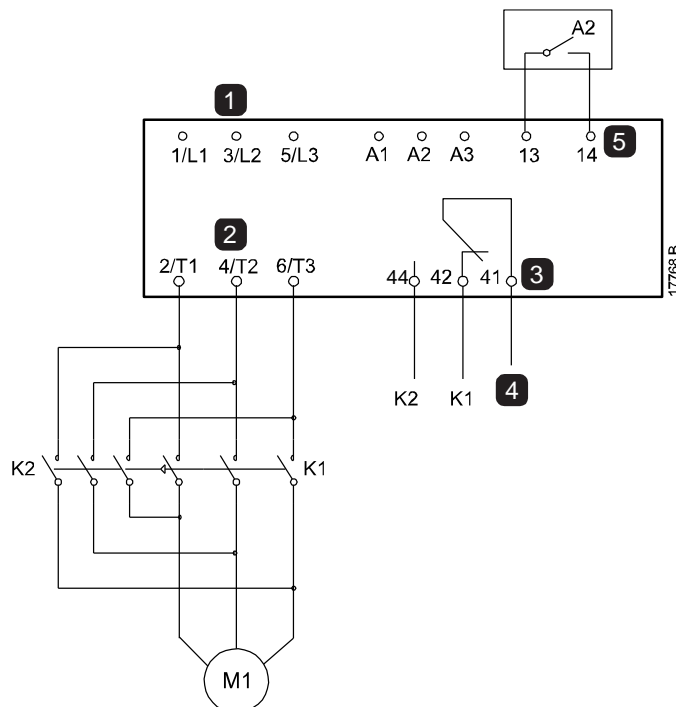

1	Three-phase supply	K1	Line contactor (Run)
2	Motor terminals	K2	Line contactor (Brake)
3	Relay output A	A2	Zero speed sensor
4	K1/K2 coil supply		
5	Programmable input A		

8.11 Pump clean

The starter can perform a pump clean function before soft starting the motor. This can help dislodge debris from the impeller.

Pump clean starts the motor in reverse then forward direction, then stops the motor. Pump clean can be configured to repeat the process up to 5 times. After the specified number of cleaning cycles, the starter performs the programmed soft start.

Pump clean operation is controlled by the start/stop input (11, 12). A programmable input must be set to pump clean (refer to parameter 7A *Input A Function* for details) and the input must be closed when the start signal is applied.

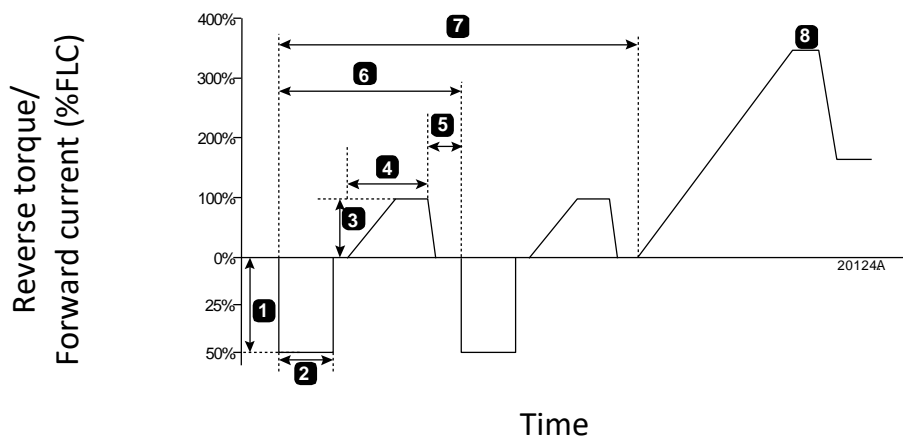

1	Reverse Torque (parameter 11A)	5	Pump Stop Time (parameter 11F)
2	Reverse Time (parameter 11B)	6	Cleaning cycle
3	Forward Current Limit (parameter 11C)	7	Pump Clean Cycles (parameter 11G)
4	Forward Time (parameter 11D)	8	Programmed soft start

8.12 Reverse direction operation

The starter can control a reversing contactor, to operate the motor in reverse direction. When reverse operation is selected, the starter will perform a soft start using the opposite phase sequence from normal operation. The starter will keep the reverse relay in the same state until the end of the starting/stopping cycle.

Reverse operation is controlled by the start/stop input (11, 12). A programmable input must be set to reverse direction (parameter 7A *Input A Function*) and an output must be set to reversing contactor (parameter 8A *Relay A Function*).

The input must be closed when the start signal is applied. The starter will keep the reverse relay in the same state until the end of the starting/stopping cycle.

This example shows a simple installation, but many different configurations are possible depending on your application requirements. Contact your local supplier for an application note showing more installation options.

**NOTE**

The first start after the direction is changed will be constant current.

**NOTE**

If phase sequence protection is required, install the reversing contactor on the output (motor) side of the soft starter.

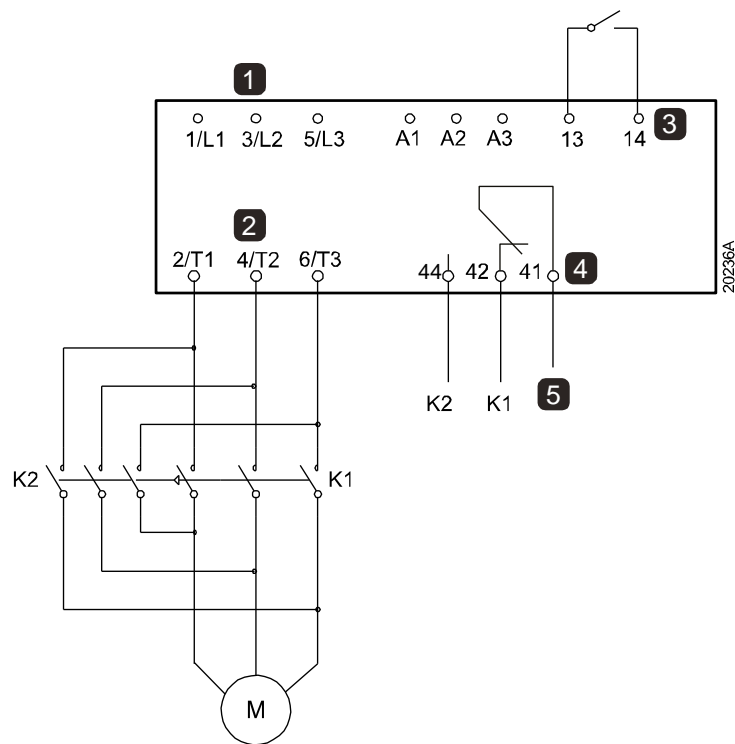

1	Three-phase supply	K1	Forward run contactor
2	Motor terminals	K2	Reversing contactor
3	Programmable input A (set = Reverse Direction)		
4	Relay output A (set = Reversing Contactor)		
5	K1/K2 coil supply		

8.13 Jog operation

Jog runs the motor at reduced speed, to allow alignment of the load or to assist servicing. The motor can be jogged in either forward or reverse direction.

Jog is only available when the starter is controlled via the digital inputs (parameter 1A *Command Source* = 'Digital Input'). To operate in jog, a programmable input must be set to jog (see parameter 7A for details) and the input must be closed when the start signal is applied.



CAUTION

Slow speed running is not intended for continuous operation due to reduced motor cooling.

Jog operation causes the motor to heat faster than the rate calculated by the motor thermal model. If you are using jog, install a motor thermistor or allow sufficient restart delay (parameter 5P).

The maximum available torque for jog forward is approximately 50%~75% of motor full load torque (FLT) depending on the motor. The torque when the motor is jogged in reverse is approximately 25%~50% of FLT.

Parameters 2H and 3J *Jog Torque* control how much of the maximum available jog torque the soft starter will apply to the motor.



NOTE

Torque settings above 50% may cause increased shaft vibration.

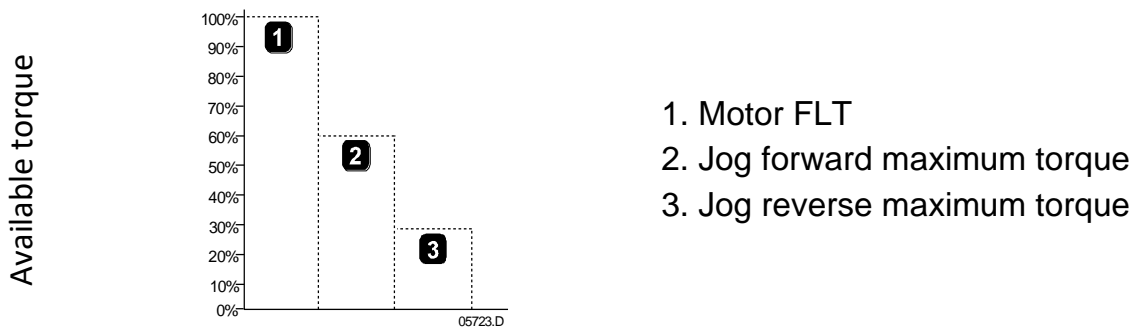

8.14 Inside delta operation

When connecting in inside delta, enter the motor full load current (FLC) for parameter 1B. The EMX4i will automatically detect whether the motor is connected in-line or inside delta and will calculate the correct inside delta current level.

Adaptive Control, Jog, Brake and PowerThrough functions are not supported with inside delta (six-wire) operation. If these functions are programmed when the starter is connected inside delta the behaviour, is as given below:

Unsupported option	Replacement behaviour
Adaptive control start	The starter performs a constant current start.
Adaptive control stop	If parameter 2J <i>Stop Time</i> is set >0 seconds, the starter performs a voltage ramp stop. If parameter 2J is set to 0 seconds the starter performs a coast to stop.
Jog	The starter issues a warning with the error message Unsupported option.
DC brake	The starter performs a coast to stop.
Soft brake	The starter performs a coast to stop.
PowerThrough	The starter trips with the error message Lx-Tx Shorted.



NOTE

When connected in inside delta, the EMX4i will not detect phase loss on T2 during run.



NOTE

If the starter is not correctly detecting the motor connection, use parameter 20F *Motor Connection*.

8.15 Secondary motor set

The starter can be programmed with two separate starting and stopping profiles. This allows the soft starter to control the motor in two different starting and stopping configurations.

The secondary motor set is ideal for dual winding (Dahlander) motors, multi-motor applications, or situations where the motor may start in two different conditions (such as loaded and unloaded conveyors).

The secondary motor set can also be used for duty/standby applications.



NOTE

For duty/standby applications, set parameter 6Q *Motor Overload* to 'Log Only' and install temperature protection for each motor.

To use the secondary motor set, a programmable input must be set to 'Motor Set Select' and the input must be closed before a start command is given (see *7A Input A Function* and *7E Input B Function*). The starter checks which motor set to use at a start, and will use that motor set for the entire start/stop cycle.

9. Programmable parameters

9.1 Main menu

The main menu lets you view and change programmable parameters that control how the EMX4i operates.

To open the main menu, press ► then scroll to Main Menu and press ► again.



NOTE

Parameters for smart card functions are only visible in the parameter list if the smart card is installed.

9.2 Altering parameter values

To change a parameter value:

- scroll to the appropriate parameter in the main menu and press ► to enter edit mode.
- to alter the parameter setting, use the ▲ and ▼ buttons. Pressing ▲ or ▼ once will increase or decrease the value by one unit. If the button is held for longer than five seconds, the value will increase or decrease at a faster rate.
- to save changes, press ►. The setting shown on the display will be saved and the keypad will return to the parameter list.
- to cancel changes, press ◀. The keypad will ask for confirmation, then return to the parameter list without saving changes.

9.3 Adjustment lock

You can prevent users from altering parameter settings by turning on the adjustment lock (parameter 10G *Adjustment Lock*).

If a user attempts to change a parameter value when the adjustment lock is active, an error message is displayed:

Access Denied Adj Lock is On

9.4 Parameter list

	Parameter Group	Default Setting
1	Motor Details	
1A	<i>Command Source</i>	Digital Input
1B	<i>Motor Full Load Current</i>	Model dependent
1C	<i>Motor kW</i>	0 kW
1D	<i>Reserved-1</i>	
1E	<i>Reserved-2</i>	
1F	<i>Motor Service Factor</i>	105%
1G	<i>Trip Class</i>	10
2	Motor Start/Stop	
2A	<i>Start Mode</i>	Constant Current
2B	<i>Start Ramp Time</i>	00:10 (mm:ss)
2C	<i>Initial Current</i>	200%
2D	<i>Current Limit</i>	350%
2E	<i>Adaptive Start Profile</i>	Constant Acceleration
2F	<i>Kickstart Time</i>	000 ms
2G	<i>Kickstart Level</i>	500%
2H	<i>Jog Torque</i>	50%
2I	<i>Stop Mode</i>	TVR Soft Stop
2J	<i>Stop Time</i>	00:00 (mm:ss)
2K	<i>Adaptive Stop Profile</i>	Constant Deceleration
2L	<i>Adaptive Control Gain</i>	75%
2M	<i>Multi Pump</i>	Single Pump
2N	<i>Start Delay</i>	00:00 (mm:ss)
2O	<i>DC Brake Torque</i>	20%
2P	<i>DC Brake Time</i>	00:01 (mm:ss)
2Q	<i>Brake Current Limit</i>	250%
2R	<i>Soft Brake Delay</i>	400 ms
3	Motor Start/Stop 2	
3A	<i>Motor Full Load Current-2</i>	Model dependent
3B	<i>Motor kW-2</i>	0 kW
3C	<i>Start Mode-2</i>	Constant Current
3D	<i>Start Ramp Time-2</i>	00:10 (mm:ss)
3E	<i>Initial Current-2</i>	200%
3F	<i>Current Limit-2</i>	350%
3G	<i>Adaptive Start Profile-2</i>	Constant Acceleration
3H	<i>Kickstart Time-2</i>	000 ms
3I	<i>Kickstart Level-2</i>	500%
3J	<i>Jog Torque-2</i>	50%

PROGRAMMABLE PARAMETERS

	Parameter Group	Default Setting
3K	<i>Stop Mode-2</i>	TVR Soft Stop
3L	<i>Stop Time-2</i>	00:00 (mm:ss)
3M	<i>Adaptive Stop Profile-2</i>	Constant Deceleration
3N	<i>Adaptive Control Gain-2</i>	75%
3O	<i>Multi Pump-2</i>	Single Pump
3P	<i>Start Delay-2</i>	00:00 (mm:ss)
3Q	<i>DC Brake Torque-2</i>	20%
3R	<i>DC Brake Time-2</i>	00:01 (mm:ss)
3S	<i>Brake Current Limit-2</i>	250%
3T	<i>Soft Brake Delay-2</i>	400 ms
4	Auto-Start/Stop	
4A	<i>Auto-Start/Stop Mode</i>	Disable
4B	<i>Run Time</i>	00:00 (hh:mm)
4C	<i>Stopped Time</i>	00:00 (hh:mm)
4D	<i>Sunday Mode</i>	Start/Stop Disable
4E	<i>Sunday Start Time</i>	00:00 (hh:mm)
4F	<i>Sunday Stop Time</i>	00:00 (hh:mm)
4G	<i>Monday Mode</i>	Start/Stop Disable
4H	<i>Monday Start Time</i>	00:00 (hh:mm)
4I	<i>Monday Stop Time</i>	00:00 (hh:mm)
4J	<i>Tuesday Mode</i>	Start/Stop Disable
4K	<i>Tuesday Start Time</i>	00:00 (hh:mm)
4L	<i>Tuesday Stop Time</i>	00:00 (hh:mm)
4M	<i>Wednesday Mode</i>	Start/Stop Disable
4N	<i>Wednesday Start Time</i>	00:00 (hh:mm)
4O	<i>Wednesday Stop Time</i>	00:00 (hh:mm)
4P	<i>Thursday Mode</i>	Start/Stop Disable
4Q	<i>Thursday Start Time</i>	00:00 (hh:mm)
4R	<i>Thursday Stop Time</i>	00:00 (hh:mm)
4S	<i>Friday Mode</i>	Start/Stop Disable
4T	<i>Friday Start Time</i>	00:00 (hh:mm)
4U	<i>Friday Stop Time</i>	00:00 (hh:mm)
4V	<i>Saturday Mode</i>	Start/Stop Disable
4W	<i>Saturday Start Time</i>	00:00 (hh:mm)
4X	<i>Saturday Stop Time</i>	00:00 (hh:mm)
5	Protection Levels	
5A	<i>Current Imbalance</i>	30%
5B	<i>Current Imbalance Delay</i>	00:03 (mm:ss)
5C	<i>Undercurrent</i>	20%

PROGRAMMABLE PARAMETERS

	Parameter Group	Default Setting
5D	<i>Undercurrent Delay</i>	00:05 (mm:ss)
5E	<i>Overcurrent</i>	400%
5F	<i>Overcurrent Delay</i>	00:00 (mm:ss)
5G	<i>Undervoltage</i>	350 V
5H	<i>Undervoltage Delay</i>	00:01 (mm:ss)
5I	<i>Overvoltage</i>	500 V
5J	<i>Overvoltage Delay</i>	00:01 (mm:ss)
5K	<i>Underpower</i>	10%
5L	<i>Underpower Delay</i>	00:05 (mm:ss)
5M	<i>Overpower</i>	150%
5N	<i>Overpower Delay</i>	00:05 (mm:ss)
5O	<i>Excess Start Time</i>	00:20 (mm:ss)
5P	<i>Restart Delay</i>	00:10 (mm:ss)
5Q	<i>Starts per Hour</i>	0
5R	<i>Phase Sequence</i>	Any sequence
6	Protection Actions	
6A	<i>Auto-Reset count</i>	0
6B	<i>Auto-Reset delay</i>	00:05 (mm:ss)
6C	<i>Current Imbalance</i>	Soft Trip and Log
6D	<i>Undercurrent</i>	Soft Trip and Log
6E	<i>Overcurrent</i>	Soft Trip and Log
6F	<i>Undervoltage</i>	Soft Trip and Log
6G	<i>Overvoltage</i>	Soft Trip and Log
6H	<i>Underpower</i>	Log Only
6I	<i>Overpower</i>	Log Only
6J	<i>Excess Start Time</i>	Soft Trip and Log
6K	<i>Input A Trip</i>	Soft Trip and Log
6L	<i>Input B Trip</i>	Soft Trip and Log
6M	<i>Network Communication</i>	Soft Trip and Log
6N	<i>Remote Keypad Fault</i>	Soft Trip and Log
6O	<i>Frequency</i>	Soft Trip and Log
6P	<i>Phase Sequence</i>	Soft Trip and Log
6Q	<i>Motor Overload</i>	Soft Trip and Log
6R	<i>Motor Thermistor Circuit</i>	Soft Trip and Log
6S	<i>Shorted SCR Action</i>	3-Phase Control Only
6T	<i>Battery/Clock</i>	Soft Trip and Log
7	Inputs	
7A	<i>Input A Function</i>	Input Trip (N/O)
7B	<i>Input A Trip</i>	Operating Only

PROGRAMMABLE PARAMETERS

	Parameter Group	Default Setting
7C	<i>Input A Trip Delay</i>	00:00 (mm:ss)
7D	<i>Input A Initial Delay</i>	00:00 (mm:ss)
7E	<i>Input B Function</i>	Input Trip (N/O)
7F	<i>Input B Trip</i>	Operating Only
7G	<i>Input B Trip Delay</i>	00:00 (mm:ss)
7H	<i>Input B Initial Delay</i>	00:00 (mm:ss)
7I	<i>Reset/Enable Logic</i>	Normally Closed (N/C)
7J	<i>Input A Name</i>	Input A Trip
7K	<i>Input B Name</i>	Input B Trip
8	Relay Outputs	
8A	<i>Relay A Function</i>	Run
8B	<i>Relay A On Delay</i>	00:00 (mm:ss)
8C	<i>Relay A Off Delay</i>	00:00 (mm:ss)
8D	<i>Relay B Function</i>	Run
8E	<i>Relay B On Delay</i>	00:00 (mm:ss)
8F	<i>Relay B Off Delay</i>	00:00 (mm:ss)
8G	<i>Low Current Flag</i>	50%
8H	<i>High Current Flag</i>	100%
8I	<i>Motor Overload Flag</i>	80%
8J	<i>Main Contactor Time</i>	400 ms
9	Analog Output	
9A	<i>Analog Output A</i>	Current (% FLC)
9B	<i>Analog A Scale</i>	4-20 mA
9C	<i>Analog A Maximum Adjustment</i>	100%
9D	<i>Analog A Minimum Adjustment</i>	000%
10	Display	
10A	<i>Language</i>	English
10B	<i>Temperature Scale</i>	Celsius
10C	<i>Graph Timebase</i>	30 seconds
10D	<i>Graph Maximum Adjustment</i>	400%
10E	<i>Graph Minimum Adjustment</i>	0%
10F	<i>Current Calibration</i>	100%
10G	<i>Adjustment Lock</i>	Read & Write
10H	<i>User Parameter 1</i>	Current
10I	<i>User Parameter 2</i>	Motor Voltage
10J	<i>User Parameter 3</i>	Mains Frequency
10K	<i>User Parameter 4</i>	Motor pf
10L	<i>User Parameter 5</i>	Motor Power
10M	<i>User Parameter 6</i>	Motor Overload (%)

PROGRAMMABLE PARAMETERS

	Parameter Group	Default Setting
11	Pump Clean	
	11A <i>Reverse Torque</i>	20%
	11B <i>Reverse Time</i>	00:10 (mm:ss)
	11C <i>Forward Current Limit</i>	100%
	11D <i>Forward Time</i>	00:10 (mm:ss)
	11E <i>Pump Stop Mode</i>	Coast to stop
	11F <i>Pump Stop Time</i>	00:10 (mm:ss)
	11G <i>Pump Clean Cycles</i>	1
12	Communications Card	
	12A <i>Modbus Address</i>	1
	12B <i>Modbus Baud Rate</i>	9600
	12C <i>Modbus Parity</i>	None
	12D <i>Modbus Timeout</i>	Off
	12E <i>DeviceNet Address</i>	0
	12F <i>DeviceNet Baud Rate</i>	125 kB
	12G <i>Profibus Address</i>	1
	12H <i>Gateway Address</i>	192
	12I <i>Gateway Address 2</i>	168
	12J <i>Gateway Address 3</i>	0
	12K <i>Gateway Address 4</i>	100
	12L <i>IP Address</i>	192
	12M <i>IP Address 2</i>	168
	12N <i>IP Address 3</i>	0
	12O <i>IP Address 4</i>	2
	12P <i>Subnet Mask</i>	255
	12Q <i>Subnet Mask 2</i>	255
	12R <i>Subnet Mask 3</i>	255
	12S <i>Subnet Mask 4</i>	0
	12T <i>DHCP</i>	Disable
	12U <i>Location ID</i>	0
20	Advanced	
	20A <i>Tracking Gain</i>	50%
	20B <i>Pedestal Detect</i>	80%
	20C <i>Bypass Contactor Delay</i>	100 ms
	20D <i>Model Rating</i>	Model dependent
	20E <i>Screen Timeout</i>	1 minute
	20F <i>Motor Connection</i>	Auto-detect
	20G <i>External Bypass</i>	Disable
	20H <i>Shunt Trip Mode</i>	Disable

	Parameter Group	Default Setting
30	Pump Input Configuration	
	30A <i>Pressure Sensor Type</i>	None
	30B <i>Pressure Units</i>	kPa
	30C <i>Pressure at 4 mA</i>	0
	30D <i>Pressure at 20 mA</i>	0
	30E <i>Flow Sensor Type</i>	None
	30F <i>Flow Units</i>	litres/second
	30G <i>Flow at 4 mA</i>	0
	30H <i>Flow at 20 mA</i>	0
	30I <i>Units per Minute at Max Flow</i>	0
	30J <i>Pulses per Minute at Max Flow</i>	0
	30K <i>Units per Pulse</i>	0
	30L <i>Depth Sensor Type</i>	None
	30M <i>Depth Units</i>	metres
	30N <i>Depth at 4 mA</i>	0
	30O <i>Depth at 20 mA</i>	0
31	Flow Protection	
	31A <i>High Flow Trip Level</i>	10
	31B <i>Low Flow Trip Level</i>	5
	31C <i>Flow Start Delay</i>	00:00:500 (mm:ss:ms)
	31D <i>Flow Response Delay</i>	00:00:500 (mm:ss:ms)
32	Pressure Protection	
	32A <i>High Pressure Trip Level</i>	10
	32B <i>High Pressure Start Delay</i>	00:00:500 (mm:ss:ms)
	32C <i>High Pressure Response Delay</i>	00:00:500 (mm:ss:ms)
	32D <i>Low Pressure Trip Level</i>	5
	32E <i>Low Pressure Start Delay</i>	00:00:500 (mm:ss:ms)
	32F <i>Low Pressure Response Delay</i>	00:00:500 (mm:ss:ms)
33	Pressure Control	
	33A <i>Pressure Control Mode</i>	Off
	33B <i>Start Pressure Level</i>	5
	33C <i>Start Response Delay</i>	00:00:500 (mm:ss:ms)
	33D <i>Stop Pressure Level</i>	10
	33E <i>Stop Response Delay</i>	00:00:500 (mm:ss:ms)
34	Depth Protection	
	34A <i>Depth Trip Level</i>	5
	34B <i>Depth Reset Level</i>	10
	34C <i>Depth Start Delay</i>	00:00:500 (mm:ss:ms)

PROGRAMMABLE PARAMETERS

	Parameter Group	Default Setting
34D	<i>Depth Response Delay</i>	00:00:500 (mm:ss:ms)
35	Thermal Protection	
35A	<i>Temperature Sensor Type</i>	None
35B	<i>Temperature Trip Level</i>	40
36	Pump Trip Action	
36A	<i>Pressure Sensor</i>	Soft Trip and Log
36B	<i>Flow Sensor</i>	Soft Trip and Log
36C	<i>Depth Sensor</i>	Soft Trip and Log
36D	<i>High Pressure</i>	Soft Trip and Log
36E	<i>Low Pressure</i>	Soft Trip and Log
36F	<i>High Flow</i>	Soft Trip and Log
36G	<i>Low Flow</i>	Soft Trip and Log
36H	<i>Flow Switch</i>	Soft Trip and Log
36I	<i>Well Depth</i>	Soft Trip and Log
36J	<i>RTD/PT100 B</i>	Soft Trip and Log
40	Ground Fault	
40A	<i>Ground Fault Level</i>	0 A
40B	<i>Ground Fault Delay</i>	00:01 (mm:ss)
40C	<i>Ground Fault Trip Active</i>	Operating Only
40D	<i>Ground Fault Action</i>	Soft Trip and Log
40E	<i>Ground Fault CT Ratio</i>	2000:1
41	Calibrate 4-20mA	
41A	<i>4 mA Calibration</i>	100%
41B	<i>20 mA Calibration</i>	100%

9.5 1 Motor Details

1A – Command Source

Options:	Digital Input (default)	The EMX4i will accept start and stop commands from the digital inputs.
	Network	The EMX4i will accept start and stop commands from the communication expansion card.
	Keypad	The EMX4i will accept start and stop commands from the Remote Keypad.
	Clock	The EMX4i will start and stop as scheduled in parameters 4D to 4X.
	Smart Card	The EMX4i will accept start and stop commands from the smart card.
	Smart Card +	The EMX4i will accept start commands from

Clock	the smart card if they are within the operating schedule set in parameters 4D to 4X. A stop command from the smart card will be accepted regardless of the schedule.
Timer	After a start signal is received, the EMX4i will start and stop the motor according to the timers set in parameters 4B and 4C.

Description: Selects the command source for controlling the soft starter.

1B – Motor Full Load Current

Range: Model dependent

Description: Matches the starter to the connected motor's full load current. Set to the full load current (FLC) rating shown on the motor nameplate.

1C – Motor kW

Range: 1 - 9999 kW **Default:** 1

Description: Sets the running power of the connected motor, in kilowatts. This setting is the basis for power reporting and protection.



NOTE

The motor nameplate may state different power ratings for different supply voltages or power connections. Ensure that the motor kW setting is accurate for the installation.

1D – Reserved-1

Description: This parameter is reserved for future use.

1E – Reserved-2

Description: This parameter is reserved for future use.

1F – Motor Service Factor

Range: 100% - 130% **Default:** 105%

Description: Sets the motor service factor used by the thermal model. If the motor runs at full load current, it will reach 100%. Set according to the motor datasheet.



NOTE

Parameter 1F determines the trip current for motor overload protection. The default settings of parameters 1F and 1G provide Motor Overload Protection: Class 10, Trip Current 105% of FLA (full load amperage) or equivalent.

Description: Selects which profile the EMX4i will use for an Adaptive Control soft start.

**NOTE**

The starter will apply the current limit on all soft starts, including adaptive control. If the current limit is too low or the start ramp time (parameter 2B) is too short, the motor may not start successfully.

2F – Kickstart Time

Range: 0 – 2000 milliseconds **Default:** 0000 milliseconds

Description: Sets the kickstart duration. A setting of 0 disables kickstart.

2G – Kickstart Level

Range: 100% - 700% FLC **Default:** 500%

Description: Sets the level of the kickstart current.

**CAUTION**

Kickstart subjects the mechanical equipment to increased torque levels. Ensure the motor, load and couplings can handle the additional torque before using this feature.

2H – Jog Torque

Range: 20% - 100% **Default:** 50%

Description: Sets the current limit for jog operation. The EMX4i can jog the motor at a reduced speed, which allows precise positioning of belts and flywheels. Jog can be used for either forward or reverse operation.

2I – Stop Mode

Options: Coast to stop DC Brake
TVR Soft Stop (default) Soft Brake
Adaptive Control

Description: Selects the stop mode.

2J – Stop Time

Range: 0:00 - 4:00 (minutes:seconds) **Default:** 0 second

Description: Sets the time for soft stopping the motor using timed voltage ramp or Adaptive Control.

If a main contactor is installed, the contactor must remain closed until the end of the stop time. Use the main contactor output (33, 34) to control the main contactor.

2K – Adaptive Stop Profile

Options: Early Deceleration
Constant Deceleration (default)

PROGRAMMABLE PARAMETERS

Description: Late Deceleration
Selects which profile the EMX4i will use for an Adaptive Control soft stop.

2L – Adaptive Control Gain

Range: 1% - 200% **Default:** 75%

Description: Adjusts the performance of Adaptive Control. This setting affects both starting and stopping control.

2M – Multi Pump

Options: Single Pump (default)
Manifold Pump

Description: Adjusts the performance of adaptive control to suit installations with multiple pumps connected to a common outlet manifold.

2N – Start Delay

Range: 0:00 - 60:00 (minutes:seconds) **Default:** 0 second

Description: Sets a delay after the starter receives a start command, before it starts the motor.

2O – DC Brake Torque

Range: 20% - 100% **Default:** 20%

Description: Sets the amount of brake torque the EMX4i will use to slow the motor.

2P – DC Brake Time

Range: 0:01 - 0:30 (minutes:seconds) **Default:** 1 second

Description: Sets the duration for DC injection during a braking stop.

2Q – Brake Current Limit

Range: 100% - 600% FLC **Default:** 250%

Description: Sets the current limit for soft brake.

2R – Soft Brake Delay

Range: 400 - 2000 milliseconds **Default:** 400 milliseconds

Description: Sets the time the soft starter will wait after a stop signal is received, before it begins to supply braking current to the motor. Set to allow time for K1 and K2 to switch.

9.7 3 Motor Start/Stop-2

The parameters in this group control the operation of the secondary configuration of the motor. Use the programmable input to select the active motor set.

Refer to *Secondary motor set* on page 100 for details.

3A – Motor Full Load Current-2

Range: Model dependent

Description: Sets the secondary motor's full load current.

3B – Motor kW-2

Range: 0 - 9999 kW **Default:** 0

Description: Sets the running power of the secondary motor, in kilowatts.

3C – Start Mode-2

Options: Constant Current (default)
Adaptive Control

Description: Selects the soft start mode.

3D – Start Ramp Time-2

Range: 0:01 - 3:00 (minutes:seconds) **Default:** 10 seconds

Description: Sets the total start time for an Adaptive Control start or the ramp time for current ramp starting (from the initial current to the current limit).

3E – Initial Current-2

Range: 100% - 600% FLC **Default:** 200%

Description: Sets the initial start current level for current ramp starting, as a percentage of motor full load current. Set so that the motor begins to accelerate immediately after a start is initiated.

If current ramp starting is not required, set the initial current equal to the current limit.

3F – Current Limit-2

Range: 100% - 600% FLC **Default:** 350%

Description: Sets the current limit for constant current and current ramp soft starting, as a percentage of motor full load current.



NOTE

The starter will apply the current limit on all soft starts, including adaptive control. If the current limit is too low or the start ramp time (parameter 2B) is too short, the motor may not start successfully.

3G – Adaptive Start Profile-2

Options: Early Acceleration
Constant Acceleration (default)
Late Acceleration

Description: Selects which profile the EMX4i will use for an Adaptive Control soft start.

3H – Kickstart Time-2

Range: 0 – 2000 milliseconds **Default:** 0000 milliseconds

Description: Sets the kickstart duration. A setting of 0 disables kickstart.

3I – Kickstart Level-2

Range: 100% - 700% FLC **Default:** 500%

Description: Sets the level of the kickstart current.

3J – Jog Torque-2

Range: 20% - 100% **Default:** 50%

Description: Sets the current limit for jog operation.

3K – Stop Mode-2

Options: Coast to stop
TVR Soft Stop (default)
Adaptive Control
DC Brake
Soft Brake

Description: Selects the stop mode.

3L – Stop Time-2

Range: 0:00 - 4:00 (minutes:seconds) **Default:** 0 second

Description: Sets the time for soft stopping the motor using timed voltage ramp or Adaptive Control.

If a main contactor is installed, the contactor must remain closed until the end of the stop time. Use the main contactor output (33, 34) to control the main contactor.

3M – Adaptive Stop Profile-2

Options: Early Deceleration
Constant Deceleration (default)
Late Deceleration

Description: Selects which profile the EMX4i will use for an Adaptive Control soft stop.

3N – Adaptive Control Gain-2**Range:** 1% - 200% **Default:** 75%**Description:** Adjusts the performance of Adaptive Control. This setting affects both starting and stopping control.**3O – Multi Pump-2****Options:** Single Pump (default)
Manifold Pump**Description:** Adjusts the performance of adaptive control to suit installations with multiple pumps connected to a common outlet manifold.**3P – Start Delay-2****Range:** 0:00 - 60:00 (minutes:seconds) **Default:** 0 second**Description:** Sets a delay after the starter receives a start command, before it starts the motor.**3Q – DC Brake Torque-2****Range:** 20% - 100% **Default:** 20%**Description:** Sets the amount of brake torque the EMX4i will use to slow the motor.**3R – DC Brake Time-2****Range:** 0:01 - 0:30 (minutes:seconds) **Default:** 1 second**Description:** Sets the duration for DC injection during a braking stop.**3S – Brake Current Limit-2****Range:** 100% - 600% FLC **Default:** 250%**Description:** Sets the current limit for soft brake.**3T – Soft Brake Delay-2****Range:** 400 - 2000 milliseconds **Default:** 400 milliseconds**Description:** Sets the time the soft starter will wait after a stop signal is received, before it begins to supply braking current to the motor. Set to allow time for K1 and K2 to switch.

9.8 4 Auto-Start/Stop

The EMX4i can be configured to automatically start and/or stop the motor at a particular time, or run it in cycles of a specified duration.

4A – Auto-Start/Stop Mode

Options: Disable (default)
 Enable Clock Mode
 Enable Timer Mode

Description: Enable or disable auto-start/stop operation.

4B – Run Time

Range: 00:00 - 23:59 hh:mm **Default:** 00:00

Description: Sets the duration for the starter to run, after a timer mode auto-start.

4C – Stopped Time

Range: 00:00 - 23:59 hh:mm **Default:** 00:00

Description: Sets the duration for the starter to remain stopped, when operating in timer mode.

4D – Sunday Mode

Options: Start/Stop Disable Disables auto-start/stop control. Any times scheduled in parameters 4E or 4F will be ignored.
 Start Only Enable Enables auto-start control. Any auto-stop times scheduled in parameter 4F will be ignored.
 Stop Only Enable Enables auto-stop control. Any auto-start times scheduled in parameter 4E will be ignored.
 Start/Stop Enable Enables auto-start and auto-stop control.

Description: Enables or disables auto-start/stop for Sunday.

4E – Sunday Start Time

Range: 00:00 - 23:59 **Default:** 00:00

Description: Sets the auto-start time for Sunday (24 hour format).

4F – Sunday Stop Time

Range: 00:00 - 23:59 **Default:** 00:00

Description: Sets the auto-stop time for Sunday (24 hour format).

4G – Monday Mode

Options: Start/Stop Disable (default) Stop Only Enable
 Start Only Enable Start/Stop Enable

Description: Enables or disables auto-start/stop for Monday.

4H – Monday Start Time

Range: 00:00 - 23:59 **Default:** 00:00

Description: Sets the auto-start time for Monday (24 hour format).

4I – Monday Stop Time

Range: 0:00 - 23:59 **Default:** 00:00

Description: Sets the auto-stop time for Monday (24 hour format).

4J – Tuesday Mode

Options:	Start/Stop Disable (default)	Stop Only Enable
	Start Only Enable	Start/Stop Enable

Description: Enables or disables auto-start/stop for Tuesday.

4K – Tuesday Start Time

Range: 00:00 - 23:59 **Default:** 00:00

Description: Sets the auto-start time for Tuesday (24 hour format).

4L – Tuesday Stop Time

Range: 00:00 - 23:59 **Default:** 00:00

Description: Sets the auto-stop time for Tuesday (24 hour format).

4M – Wednesday Mode

Options:	Start/Stop Disable (default)	Stop Only Enable
	Start Only Enable	Start/Stop Enable

Description: Enables or disables auto-start/stop for Wednesday.

4N – Wednesday Start Time

Range: 00:00 - 23:59 **Default:** 00:00

Description: Sets the auto-start time for Wednesday (24 hour format).

4O – Wednesday Stop Time

Range: 00:00 - 23:59 **Default:** 00:00

Description: Sets the auto-stop time for Wednesday (24 hour format).

4P – Thursday Mode

Options:	Start/Stop Disable (default)	Stop Only Enable
	Start Only Enable	Start/Stop Enable

Description: Enables or disables auto-start/stop for Thursday.

4Q – Thursday Start Time

Range: 00:00 - 23:59 **Default:** 00:00

Description: Sets the auto-start time for Thursday (24 hour format).

4R – Thursday Stop Time

Range: 00:00 - 23:59 **Default:** 00:00

Description: Sets the auto-stop time for Thursday (24 hour format).

4S – Friday Mode

Options: Start/Stop Disable (default) Stop Only Enable
 Start Only Enable Start/Stop Enable

Description: Enables or disables auto-start/stop for Friday.

4T – Friday Start Time

Range: 00:00 - 23:59 **Default:** 00:00

Description: Sets the auto-start time for Friday (24 hour format).

4U – Friday Stop Time

Range: 00:00 - 23:59 **Default:** 00:00

Description: Sets the auto-stop time for Friday (24 hour format).

4V – Saturday Mode

Options: Start/Stop Disable (default) Stop Only Enable
 Start Only Enable Start/Stop Enable

Description: Enables or disables auto-start/stop for Saturday.

4W – Saturday Start Time

Range: 00:00 - 23:59 **Default:** 00:00

Description: Sets the auto-start time for Saturday (24 hour format).

4X – Saturday Stop Time

Range: 00:00 - 23:59 **Default:** 00:00

Description: Sets the auto-stop time for Saturday (24 hour format).

9.9 5 Protection Levels

5A – Current Imbalance

Range: 10% - 50% **Default:** 30%

Description: Sets the trip point for current imbalance protection.

5B – Current Imbalance Delay

Range: 0:00 - 4:00 (minutes:seconds) **Default:** 3 seconds

Description: Slows the EMX4i's response to current imbalance, avoiding trips due to momentary fluctuations.

5C – Undercurrent

Range: 0% - 100% **Default:** 20%

Description: Sets the trip point for undercurrent protection, as a percentage of motor full load current. Set to a level between

the motor's normal working range and the motor's magnetising (no load) current (typically 25% to 35% of full load current). A setting of 0% disables undercurrent protection.

5D – Undercurrent Delay

Range: 0:00 - 4:00 (minutes:seconds) **Default:** 5 seconds

Description: Slows the EMX4i's response to undercurrent, avoiding trips due to momentary fluctuations.

5E – Overcurrent

Range: 80% - 600% **Default:** 400%

Description: Sets the trip point for overcurrent protection, as a percentage of motor full load current.

5F – Overcurrent Delay

Range: 0:00 - 1:00 (minutes:seconds) **Default:** 0 second

Description: Slows the EMX4i's response to overcurrent, avoiding trips due to momentary overcurrent events.

5G – Undervoltage

Range: 100 - 1200 V **Default:** 350

Description: Sets the trip point for undervoltage protection. Set as required.

**NOTE**

Voltage protections will not operate correctly until the starter is in Run mode.

5H – Undervoltage Delay

Range: 0:01 - 1:00 (minutes:seconds) **Default:** 1 second

Description: Slows the EMX4i's response to undervoltage, avoiding trips due to momentary fluctuations.

5I – Overvoltage

Range: 100 - 1500 V **Default:** 500

Description: Sets the trip point for overvoltage protection. Set as required.

5J – Overvoltage Delay

Range: 0:01 - 1:00 (minutes:seconds) **Default:** 1 second

Description: Slows the EMX4i's response to overvoltage, avoiding trips due to momentary fluctuations.

5K – Underpower

Range: 10% -120% **Default:** 10%

Description: Sets the trip point for underpower protection. Set as required.

5L – Underpower Delay

Range: 0:01 - 1:00 (minutes:seconds) **Default:** 5 seconds

Description: Slows the EMX4i's response to underpower, avoiding trips due to momentary fluctuations.

5M – Overpower

Range: 80% - 200% **Default:** 150%

Description: Sets the trip point for overpower protection. Set as required.

5N – Overpower Delay

Range: 0:01 - 1:00 (minutes:seconds) **Default:** 5 seconds

Description: Slows the EMX4i's response to overpower, avoiding trips due to momentary fluctuations.

5O – Excess Start Time

Range: 0:00 - 4:00 (minutes:seconds) **Default:** 20 seconds

Description: Excess start time is the maximum time the EMX4i will attempt to start the motor. If the motor does not transition to Run mode within the programmed limit, the starter will trip. Set for a period slightly longer than required for a normal healthy start. A setting of 0 disables excess start time protection.

5P – Restart Delay

Range: 00:01 - 60:00 (minutes:seconds) **Default:** 10 seconds

Description: The EMX4i can be configured to force a delay between the end of a stop and the beginning of the next start. During the restart delay period, the screen shows the time remaining before another start can be attempted.

5Q – Starts per Hour

Range: 0 - 10 **Default:** 0

Description: Sets the maximum number of starts the EMX4i will attempt in a 60 minute period.



CAUTION

A setting of 0 disables this protection. It will allow an indefinite number of starts per hour and no cooling time. In this case, the thermal model

will only provide motor overload protection while starting and running as cooling time is zero, and the model resets before each start.

5R – Phase Sequence

Options: Any sequence (default)
Positive Only
Negative Only

Description: Selects which phase sequences the soft starter will allow at a start. During its pre-start checks, the starter examines the sequence of the phases at its input terminals and trips if the actual sequence does not match the selected option.



CAUTION

When using DC brake, the mains supply must be connected to the soft starter (input terminals L1, L2, L3) in positive phase sequence and parameter 5R *Phase Sequence* must be set to Positive Only.

9.10 6 Protection Action

6A – *Auto-Reset count*

Range: 0 – 5 **Default:** 0

Description: Sets how many times the soft starter will auto reset, if it continues to trip.

The reset counter increases by one each time the soft starter auto resets, and resets after a successful start.

Setting this parameter to zero disables auto-reset.

6B – *Auto-Reset delay*

Range: 0:05 - 15:00 (minutes:seconds) **Default:** 5 seconds

Description: Sets a delay before the soft starter will auto reset a trip.

6C – *Current Imbalance*

Options:	Soft Trip and Log (default)	The soft starter will stop the motor as selected in parameter 2I or 3K <i>Stop Mode</i> , then enter trip state. The trip must be reset before the starter can restart.
	Soft Trip and Reset	The soft starter will stop the motor as selected in parameter 2I or 3K <i>Stop Mode</i> , then enter trip state. The trip will reset after the auto-reset delay.
	Trip Starter	The soft starter will remove power and the motor will coast to stop. The trip must be reset before the starter can restart.
	Trip and Reset	The soft starter will remove power and the motor will coast to stop. The trip will reset after the auto-reset delay.
	Warn and Log	The protection will be written to the event log and the screen will show a warning message, but the soft starter will continue to operate.
	Log Only	The protection will be written to the event log but the soft starter will continue to operate.

Trip + Shunt Relay The soft starter will remove power and the motor will coast to stop. The shunt trip relay (33, 34) will activate and the circuit breaker will disconnect mains voltage from the soft starter. The circuit breaker must be manually reset before operation can resume.
 This option is only effective if parameter 20H *Shunt Trip Mode* is set to 'Enable'.

Description: Selects the soft starter's response to each protection. All protection events are written to the event log.

6D – Undercurrent

Options:

Soft Trip and Log (default)	Warn and Log
Soft Trip and Reset	Log Only
Trip Starter	Trip + Shunt Relay
Trip and Reset	

Description: Selects the soft starter's response to the protection event.

6E – Overcurrent

Options:

Soft Trip and Log (default)	Warn and Log
Soft Trip and Reset	Log Only
Trip Starter	Trip + Shunt Relay
Trip and Reset	

Description: Selects the soft starter's response to the protection event.

6F – Undervoltage

Options:

Soft Trip and Log	Warn and Log
Soft Trip and Reset	Log Only
Trip Starter (default)	Trip + Shunt Relay
Trip and Reset	

Description: Selects the soft starter's response to the protection event.

6G – Overvoltage

Options:

Soft Trip and Log (default)	Warn and Log
Soft Trip and Reset	Log Only
Trip Starter	Trip + Shunt Relay
Trip and Reset	

Description: Selects the soft starter's response to the protection event.

6H – Underpower

Options:

Log Only (default)	Trip Starter
Trip + Shunt Relay	Trip and Reset
Soft Trip and Log	Warn and Log

PROGRAMMABLE PARAMETERS

Soft Trip and Reset

Description: Selects the soft starter's response to the protection event.

6I – Overpower

Options:

Log Only (default)	Trip Starter
Trip + Shunt Relay	Trip and Reset
Soft Trip and Log	Warn and Log
Soft Trip and Reset	

Description: Selects the soft starter's response to the protection event.

6J – Excess Start Time

Options:

Soft Trip and Log (default)	Warn and Log
Soft Trip and Reset	Log Only
Trip Starter	Trip + Shunt Relay
Trip and Reset	

Description: Selects the soft starter's response to the protection event.

6K – Input A Trip

Options:

Soft Trip and Log (default)	Warn and Log
Soft Trip and Reset	Log Only
Trip Starter	Trip + Shunt Relay
Trip and Reset	

Description: Selects the soft starter's response to the protection event.

6L – Input B Trip

Options:

Soft Trip and Log (default)	Warn and Log
Soft Trip and Reset	Log Only
Trip Starter	Trip + Shunt Relay
Trip and Reset	

Description: Selects the soft starter's response to the protection event.

6M – Network Communication

Options:	Soft Trip and Log (default)	Warn and Log
	Soft Trip and Reset	Log Only
	Trip Starter	Stop
	Trip and Reset	Trip + Shunt Relay

Description: Selects the soft starter's response to the protection event. If set to Stop, the EMX4i will perform a soft stop, then can be restarted without a reset.

6N – Remote Keypad Fault

Options:	Soft Trip and Log (default)	Warn and Log
	Soft Trip and Reset	Log Only
	Trip Starter	Trip + Shunt Relay
	Trip and Reset	

Description: Selects the soft starter's response to the protection event.

6O – Frequency

Options:	Soft Trip and Log (default)	Warn and Log
	Soft Trip and Reset	Log Only
	Trip Starter	Trip + Shunt Relay
	Trip and Reset	

Description: Selects the soft starter's response to the protection event.

6P – Phase Sequence

Options:	Soft Trip and Log (default)	Warn and Log
	Soft Trip and Reset	Log Only
	Trip Starter	Trip + Shunt Relay
	Trip and Reset	

Description: Selects the soft starter's response to the protection event.

6Q – Motor Overload

Options:	Soft Trip and Log (default)	Warn and Log
	Soft Trip and Reset	Log Only
	Trip Starter	Trip + Shunt Relay
	Trip and Reset	

Description: Selects the soft starter's response to the protection event.

6R – Motor Thermistor Circuit

Options:	Soft Trip and Log (default)	Warn and Log
	Soft Trip and Reset	Log Only
	Trip Starter	Trip + Shunt Relay
	Trip and Reset	

Description: Selects the soft starter's response to the protection event.

6S – Shorted SCR Action

Options:	3-Phase Control Only (default)
	PowerThrough
	Trip + Shunt Relay

Description: Selects whether the soft starter will allow PowerThrough operation, if the soft starter is damaged on one phase. The soft starter will use two-phase control, allowing the motor to continue operating in critical applications. Refer to *PowerThrough* on page 84 for further information.

6T – Battery/Clock

Options:	Soft Trip and Log (default)	Warn and Log
	Soft Trip and Reset	Log Only
	Trip Starter	Trip + Shunt Relay
	Trip and Reset	

Description: Selects the soft starter's response to the protection event.

9.11 7 Inputs

7A – Input A Function

Options:	Command Override: Network	Overrides the setting of 1A and sets the command source to the communications network.	
	Command Override: Digital	Overrides the setting of 1A and sets the command source to the digital inputs.	
	Command Override: Keypad	Overrides the setting of 1A and sets the command source to the remote keypad.	
	Input Trip (N/O) (default)	A closed circuit across 13, 14 trips the soft starter.	
	Input Trip (N/C)	An open circuit across 13, 14 trips the soft starter.	
	Emergency Mode	A closed circuit across 13, 14 activates emergency mode. When the starter receives a start command, it will continue to run until a stop command is received, ignoring all trips and warnings.	
	Jog Forward	Activates jog operation in a forward direction.	
	Jog Reverse	Activates jog operation in reverse direction.	
	Zero Speed Sensor	An open circuit across 13, 14 indicates to the soft starter that the motor has reached a standstill. The soft starter requires a normally open (NO) zero speed sensor.	
	Motor Set Select	A closed circuit across 13, 14 instructs the starter to use the secondary motor configuration for the next start/stop cycle.	
	Reverse Direction	A closed circuit across 13, 14 instructs the starter to reverse the phase sequence for the next start.	
	Pump Clean	Activates the pump clean function.	
	Description:	Selects the function of Input A.	

7B – Input A Trip

Options:	Always Active	A trip can occur at any time when the soft starter is receiving power.
	Operating Only (default)	A trip can occur while the soft starter is running, stopping or starting.
	Run Only	A trip can only occur while the soft starter is running.

Description: Selects when an input trip can occur.

7C – Input A Trip Delay

Range: 0:00 - 4:00 (minutes:seconds) **Default:** 0 second

Description: Sets a delay between the input activating and the soft starter tripping.

7D – Input A Initial Delay

Range: 00:00 - 30:00 (minutes:seconds) **Default:** 0 second

Description: Sets a delay before an input trip can occur. The initial delay is counted from the time a start command is received. The state of the input is ignored until the initial delay has elapsed.

7E – Input B Function

Options:	Input Trip (N/O) (default)	Zero Speed Sensor
	Input Trip (N/C)	Motor Set Select
	Emergency Mode	Reverse Direction
	Jog Forward	Pump Clean
	Jog Reverse	

Description: Selects the function of Input B. Refer to parameter 7A *Input A Function* for details.

7F – Input B Trip

Options:	Always Active
	Operating Only (default)
	Run Only

Description: Selects when an input trip can occur.

7G – Input B Trip Delay

Range: 0:00 - 4:00 (minutes:seconds) **Default:** 0 second

Description: Sets a delay between the input activating and the soft starter tripping.

7H – Input B Initial Delay

Range: 00:00 - 30:00 (minutes:seconds) **Default:** 0 second

Description: Sets a delay before an input trip can occur. The initial delay is counted from the time a start command is received. The state of the input is ignored until the initial delay has elapsed.

7I – Reset/Enable Logic

Options: Normally Closed (default)
Normally Open

Description: Selects whether the reset input (10, 11) is normally open or normally closed.

**NOTE**

If the reset input is active, the starter will not operate.

7J – Input A Name

Options:	Input A Trip (default)	Controller
	Low Pressure	PLC
	High Pressure	Vibration Alarm
	Pump Fault	Field Trip
	Low Level	Interlock Trip
	High Level	Motor Overload
	No Flow	Motor Protection
	Starter Disable	Feeder Protection
		Custom Message

Description: Selects a message for the keypad to display when Input A is active.

The custom message can be loaded via the USB port. See *USB save and load* on page 68 for details.

7K – Input B Name

Options:	Input B Trip (default)	Controller
	Low Pressure	PLC
	High Pressure	Vibration Alarm
	Pump Fault	Field Trip
	Low Level	Interlock Trip
	High Level	Motor Overload
	No Flow	Motor Protection
	Starter Disable	Feeder Protection
		Custom Message

Description: Selects a message for the keypad to display when Input B is active.

The custom message can be loaded via the USB port. See *USB save and load* on page 68 for details.

9.12 8 Relay Outputs

8A – Relay A Function

Options:	Off	Relay A is not used.
	Ready	The relay is closed whenever the starter is not tripped or locked out.
	Run (default)	The Run output closes when the soft start is complete (when the starting current falls below 120% of the programmed motor full load current) and remains closed until the beginning of a stop (either soft stop or coast to stop).
	Warning	The relay closes when the starter issues a warning (refer to <i>6 Protection Action</i> on page 122).
	Trip	The relay closes when the starter trips (refer to <i>6 Protection Action</i> on page 122).
	Low Current Flag	The relay closes when the low current flag activates while the motor is running (refer to parameter 8G <i>Low Current Flag</i>).
	High Current Flag	The relay closes when the high current flag activates while the motor is running (refer to parameter 8H <i>High Current Flag</i>).
	Motor Overload Flag	The relay closes when the motor overload flag activates (refer to parameter 8I <i>Motor Overload Flag</i>).
	Soft Brake Relay	The relay closes when the soft starter receives a stop signal, and remains closed until the end of soft brake.
	Reversing Contactor	The relay will control an external contactor, for reverse operation. Refer to <i>Reverse direction operation</i> on page 96 for details.
	Trip Failsafe	The relay closes when control power is applied. The relay opens if the soft starter trips or if control power is lost.
	Operating Only	The relay is closed while the soft starter is running, stopping or starting.
Description:	Selects the function of Relay A. Relay A is a changeover relay.	

8B – Relay A On Delay

Range: 0:00 - 5:00 (minutes:seconds) **Default:** 0 second

Description: Sets the delay for changing the state of Relay A.

8C – Relay A Off Delay

Range: 0:00 - 5:00 (minutes:seconds) **Default:** 0 second

Description: Sets the delay for changing the state of Relay A.

8D – Relay B Function

Options:	Off	High Current Flag
	Ready	Motor Overload Flag
	Run (default)	Soft Brake Relay
	Warning	Reversing Contactor
	Trip	Trip Failsafe
	Low Current Flag	Operating Only

Description: Selects the function of Relay B (normally open). Refer to parameter 8A *Relay A Function*.

8E – Relay B On Delay

Range: 0:00 - 5:00 (minutes:seconds) **Default:** 0 second

Description: Sets the delay for closing Relay B.

8F – Relay B Off Delay

Range: 0:00 - 5:00 (minutes:seconds) **Default:** 0 second

Description: Sets the delay for re-opening Relay B.

The EMX4i has low and high current flags to give early warning of abnormal operation. The current flags can be configured to indicate an abnormal current level during operation, between the normal operating level and the undercurrent or instantaneous overcurrent trip levels. The flags can signal the situation to external equipment via one of the programmable outputs.

The flags clear when the current returns within the normal operating range by 10% of the programmed flag value.

8G – Low Current Flag

Range: 1% - 100% FLC **Default:** 50%

Description: Sets the level at which the low current flag operates, as a percentage of motor full load current.

8H – High Current Flag**Range:** 50% - 600% FLC **Default:** 100%**Description:** Sets the level at which the high current flag operates, as a percentage of motor full load current.**NOTE**

8G – *Low Current Flag* and 8H – *High Current Flag* only operate in bypassed/running state.

8I – Motor Overload Flag

The soft starter has a motor overload flag to give early warning of abnormal operation. The flag can be set lower than the overload limit, to indicate the motor is approaching an overload condition. The flag can signal the situation to external equipment via one of the programmable outputs.

Range: 0% - 160% **Default:** 80%**Description:** Sets the level at which the motor overload flag operates, as a percentage of the motor's thermal capacity.**8J – Main Contactor Time****Range:** 100 – 2000 milliseconds **Default:** 400 milliseconds**Description:** Sets the delay period between the starter switching the main contactor output (terminals 33, 34) and beginning the pre-start checks (before a start) or entering the not ready state (after a stop). Set according to the specifications of the main contactor used.

9.13 9 Analog Output

9A – Analog Output A

Options:	Current (% FLC) (default)	Current as a percentage of motor full load current.
	Motor Overload (%)	The motor's temperature, calculated by the thermal model.
	Motor pf	Motor power factor, measured by the soft starter.
	Motor Power (%kW)	Motor power, as a percentage of the programmed power.
	Heatsink Temperature (°C)	The soft starter's temperature, as a percentage of the heatsink's maximum allowed operating temperature.

Description: Selects which information will be reported via the analog output.

9B – Analog A Scale

Range: 0-20 mA
4-20 mA (default)

Description: Selects the range of the analog output.

9C – Analog A Maximum Adjustment

Range: 0% - 600% **Default:** 100%

Description: Sets the upper limit of the range that the analog output will represent. When the selected information is at or above the upper limit, the analog output will remain at its highest value.

9D – Analog A Minimum Adjustment

Range: 0% - 600% **Default:** 0%

Description: Sets the lower limit of the range that the analog output will represent. When the selected information is at or below the lower limit, the analog output will remain at its lowest value.



NOTE

If the values of parameters 9C and 9D are far apart, the analog output will represent a wide dynamic range. The resolution of the output will be coarse.



NOTE

If precise accuracy is important, use parameters 41A *4 mA Calibration* and 41B *20 mA Calibration* to calibrate the analog output.

9.14 10 Display

10A – *Language*

Options:	English (default)	Português
	Chinese	Français
	Español	Italiano
	Deutsch	Russian

Description: Selects which language the keypad will use to display messages and feedback.

10B – *Temperature Scale*

Options:	Celsius (default)
	Fahrenheit

Description: Selects whether the EMX4i will display temperatures in degrees Celsius or Fahrenheit.

10C – *Graph Timebase*

Options:	30 seconds (default)
	1 minute
	30 minutes
	1 hour

Description: Sets the graph time scale. The graph will progressively replace the old data with new data.

10D – *Graph Maximum Adjustment*

Range: 0% – 600% **Default:** 400%

Description: Adjusts the upper limit of the performance graph.

10E – *Graph Minimum Adjustment*

Range: 0% - 600% **Default:** 0%

Description: Adjusts the lower limit of the performance graph.

10F – *Current Calibration*

Range: 85% - 115% **Default:** 100%

Description: Calibrates the soft starter's current monitoring circuits to match an external current metering device.

Use the following formula to determine the necessary adjustment:

$$\text{Calibration (\%)} = \frac{\text{Current shown on starter display}}{\text{Current measured by external device}}$$

10G – Adjustment Lock

Options:	Read & Write (default)	Allows users to alter parameter values in the main menu.
	Read Only	Prevents users altering parameter values in the main menu. Parameter values can still be viewed.

Description: Selects whether the keypad will allow parameters to be changed via the main menu.

10H – User Parameter 1

Options:	Blank	Displays no data in the selected area, allowing long messages to be shown without overlapping.
	Current (default)	Average rms current across all three phases
	Motor Voltage	Average rms voltage across all three phases.
	P1 Voltage	Phase 1 voltage.
	P2 Voltage	Phase 2 voltage.
	P3 Voltage	Phase 3 voltage.
	Mains Frequency	The average frequency measured on three phases.
	Motor pf	The motor's power factor, measured by the soft starter.
	Motor Power	The motor's running power in kilowatts.
	Motor Overload (%)	The motor's temperature, calculated by the thermal model.
	Hours Run	The number of hours the motor has run via the soft starter.
	Number of starts	The number of starts the EMX4i has completed since the start counter was last reset.
	Pump Pressure	The pressure at the pump, as configured in parameters 30B~30D. This information is only available if the smart card is installed.
Pump Flow	The flow at the pump, as configured in parameters 30F~30K. This information is only available if the smart card is installed.	

Well Depth	The depth of the well, as configured in parameters 30M~30O. This information is only available if the smart card is installed.
Pump Temperature	The pump temperature, as measured by the PT100. This information is only available if the smart card is installed.
Analog Output Value	The value of the analog output (refer to parameters 9A~9D).
Heatsink Temperature	The soft starter's temperature, measured at the heatsink.
Bypass Model (%)	The percentage of thermal capacity remaining in the bypass contactor.
SCR Temperature	The temperature of the SCRs, calculated by the thermal model.
Rating Capacity (%)	The thermal capacity available in the soft starter for its next start.
Ground Current	Measured ground current. This information is only available if a compatible option card is installed.

Description: Selects which information will be displayed on the main monitoring screen.

10I – User Parameter 2

Options: Refer to parameter 10H *User Parameter 1* for details.

Default: Motor Voltage

Description: Selects which information will be displayed on the main monitoring screen.

10J – User Parameter 3

Options: Refer to parameter 10H *User Parameter 1* for details.

Default: Mains Frequency

Description: Selects which information will be displayed on the programmable monitoring screen.

10K – User Parameter 4

Options: Refer to parameter 10H *User Parameter 1* for details.

Default: Motor pf

Description: Selects which information will be displayed on the programmable monitoring screen.

10L – User Parameter 5

Options: Refer to parameter 10H *User Parameter 1* for details.

Default: Motor Power

Description: Selects which information will be displayed on the programmable monitoring screen.

10M – User Parameter 6

Options: Refer to parameter 10H *User Parameter 1* for details.

Default: Motor Overload (%)

Description: Selects which information will be displayed on the programmable monitoring screen.

9.15 11 Pump Clean

11A – Reverse Torque

Range: 20% - 100% **Default:** 20%

Description: Sets the torque level for reverse jog operation during pump clean.

11B – Reverse Time

Range: 0:00 - 1:00 (minutes:seconds) **Default:** 10 seconds

Description: Sets the time for the starter to operate in reverse jog during a pump clean cycle.

11C – Forward Current Limit

Range: 100% - 600% FLC **Default:** 100%

Description: Sets the current limit for forward start operation during pump clean.

11D – Forward Time

Range: 0:00 - 1:00 (minutes:seconds) **Default:** 10 seconds

Description: Sets the time for the starter to run the motor after a forward start, during a pump clean cycle.

11E – Pump Stop Mode

Options: Coast to stop (default)
TVR Soft Stop

Description: Selects the stop mode for pump clean.

11F – Pump Stop Time

Range: 0:00 - 1:00 (minutes:seconds) **Default:** 10 seconds

Description: Sets the stopping time for the starter during a pump clean cycle.

11G – Pump Clean Cycles**Range:** 1 – 5 **Default:** 1**Description:** Sets how many times the soft starter will repeat the pump clean cycle.**9.16 12 Communications Card****12A – Modbus Address****Range:** 1 - 254 **Default:** 1**Description:** Sets the Modbus RTU network address for the soft starter.**12B – Modbus Baud Rate****Options:** 4800
9600 (default)
19200
38400**Description:** Selects the baud rate for Modbus RTU communication.**12C – Modbus Parity****Options:** None (default)
Odd
Even
10-bit**Description:** Selects the parity for Modbus RTU communication.**12D – Modbus Timeout****Options:** Off (default)
10 seconds
60 seconds
100 seconds**Description:** Selects the timeout for Modbus RTU communication.**12E – DeviceNet address****Range:** 0 - 63 **Default:** 0**Description:** Sets the DeviceNet network address for the soft starter.**12F – DeviceNet baud rate****Options:** 125 kB (default)
250 kB
500 kB**Description:** Selects the baud rate for DeviceNet communications.

12G – Profibus Address

Range: 1 - 125 **Default:** 1

Description: Sets the Profibus network address for the soft starter.

12H – Gateway Address

Range: 0 - 255 **Default:** 192

Description: Sets the first component of the network gateway address. The gateway address is set using parameters 12H~12K and the default address is 192.168.0.100.

12I – Gateway Address 2

Range: 0 - 255 **Default:** 168

Description: Sets the second component of the network gateway address.

12J – Gateway Address 3

Range: 0 - 255 **Default:** 0

Description: Sets the third component of the network gateway address.

12K – Gateway Address 4

Range: 0 - 255 **Default:** 100

Description: Sets the fourth component of the network gateway address.



NOTE

The network address can also be set via the Network Address options in the Setup Tools. Refer to *Network address* on page 71 for details.

12L – IP Address

Range: 0 - 255 **Default:** 192

Description: Sets the first component of the soft starter's IP address, for Ethernet communications. The IP address is set using parameters 12L~12O and the default address is 192.168.0.2.

12M – IP Address 2

Range: 0 - 255 **Default:** 168

Description: Sets the second component of the soft starter's IP address, for Ethernet communications.

12N – IP Address 3

Range: 0 - 255 **Default:** 0

Description: Sets the third component of the soft starter's IP address, for Ethernet communications.

12O – IP Address 4

Range: 0 - 255 **Default:** 2

Description: Sets the fourth component of the soft starter's IP address, for Ethernet communications.

**NOTE**

The network address can also be set via the Network Address options in the Setup Tools. Refer to *Network address* on page 71 for details.

12P – Subnet Mask

Range: 0 - 255 **Default:** 255

Description: Sets the first component of the network subnet mask, for Ethernet communications. The subnet mask is set using parameters 12P~12S and the default mask is 255.255.255.0.

12Q – Subnet Mask 2

Range: 0 - 255 **Default:** 255

Description: Sets the second component of the network subnet mask, for Ethernet communications.

12R – Subnet Mask 3

Range: 0 - 255 **Default:** 255

Description: Sets the third component of the network subnet mask, for Ethernet communications.

12S – Subnet Mask 4

Range: 0 - 255 **Default:** 0

Description: Sets the fourth component of the network subnet mask, for Ethernet communications.

**NOTE**

The network address can also be set via the Network Address options in the Setup Tools. Refer to *Network address* on page 71 for details.

12T – DHCP

Options: Disable (default)
Enable

Description: Selects whether the network card will accept an IP address assigned by DHCP.

**NOTE**

DHCP addressing is available with Modbus TCP and EtherNet/IP. DHCP addressing is not supported with Profinet.

12U – Location ID

Range: 0 - 65535 **Default:** 0

Description: Sets the soft starter's unique location ID.

9.17 20 Advanced

20A – Tracking Gain

Range: 1% - 200% **Default:** 50%

Description: Fine-tunes the behaviour of the adaptive control algorithm.

20B – Pedestal Detect

Range: 0% - 200% **Default:** 80%

Description: Adjusts the behaviour of the adaptive control algorithm for soft stop.

20C – Bypass Contactor Delay

Range: 50 – 200 milliseconds **Default:** 100 milliseconds

Description: Sets the starter to match the bypass contactor closing/opening time. Set according to the specifications of the bypass contactor used. If this time is too short, the starter will trip.

20D – Model Rating

Range: Model dependent

Description: The soft starter's internal model reference, as shown on the silver label on the side of the unit [1].

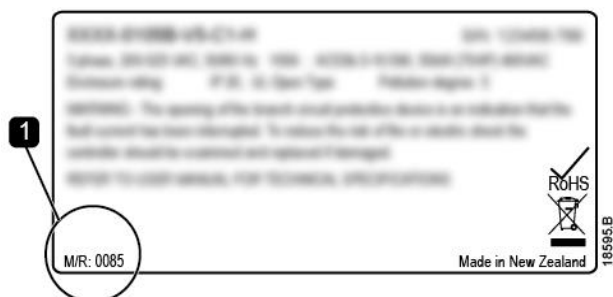

NOTE

This parameter can only be adjusted by authorised service agents.

20E – Screen Timeout

Options:

1 minute (default)	4 minutes
2 minutes	5 minutes
3 minutes	

Description: Sets the timeout for the menu to automatically close if no keypad activity is detected.

20F – Motor Connection

Options: Auto-detect (default)
In-line
Inside delta

Description: Selects whether the soft starter will automatically detect the format of the connection to the motor.

20G – External Bypass

Options: Disable (default)
Enable

Description: If a non-bypassed soft starter is installed with an external bypass contactor, the soft starter's current rating changes. Enable parameter 20G *External Bypass* to increase the maximum current rating and adjust the soft starter's thermal model.

**NOTE**

Parameter 20G *External Bypass* only applies to models EMX4i-0735C~EMX4i-1220C. Changing the setting of this parameter will have no effect on other models.

20H – Shunt Trip Mode

Options: Disable (default)
Enable

Description: Reconfigures the soft starter's main contactor output (33, 34) for use as a shunt trip relay. When the soft starter trips on selected conditions, the relay will activate and the shunt trip will trigger the circuit breaker and disconnect mains voltage from the soft starter.
Use parameters 6C~6T to select which trips will activate the shunt trip relay.

**NOTE**

If shunt trip operation is enabled, the shunt trip relay will activate for certain non-adjustable trips as well as the selected adjustable trips.

- Current at stop
- Current Read Error Lx
- EEPROM fail
- Firing Fail Px
- Instantaneous overcurrent
- Internal fault
- Motor connection
- SCR Itsm
- VZC Fail Px

9.18 30 Smart Card Parameters

Parameter groups 30 and higher are only visible if a smart card is installed and is supported by the soft starter. For parameter details, refer to the smart card user manual.

9.19 40 Ground Fault



NOTE

Ground fault protection is only available if a compatible expansion card is installed.

40A – Ground Fault Level

Range: 0 A - 50 A **Default:** 0 A

Description: Sets the trip point for ground fault protection. A setting of 0 disables this protection.

40B – Ground Fault Delay

Range: 00:00 – 01:30 mm:ss **Default:** 1 second

Description: Slows the response to ground fault variation, avoiding trips due to momentary fluctuations.

If the soft starter detects ground current above 50 A or more than 1.5 times the level set in parameter 40A, it will ignore the delay setting and trip within 1 second.

40C – Ground Fault Trip Active

Options:	Always Active	A trip can occur at any time when the soft starter is receiving power.
	Operating Only (default)	A trip can occur while the soft starter is running, stopping or starting.
	Run Only	A trip can only occur while the soft starter is running.

Description: Selects when a ground fault trip can occur.

40D – Ground Fault Action

Options:	Soft Trip and Log (default)	Warn and Log
	Soft Trip and Reset	Log Only
	Trip Starter	Trip + Shunt Relay
	Trip and Reset	

Description: Selects the soft starter's response to the protection event.

40E – Ground Fault CT Ratio

Options: 1000:1
2000:1 (default)

Description: Set to match the ratio of the ground current measuring CT.

9.20 41 Calibrate 4-20mA**41A – 4 mA Calibration**

Range: 90% - 110% **Default:** 100%

Description: Calibrates the analog output to read exactly 4 mA when the motor is not running.

41B – 20 mA Calibration

Range: 90% - 110% **Default:** 100%

Description: Calibrates the analog output to read exactly 20 mA when the motor is running at full load current.

10. Troubleshooting

10.1 Protection responses

When a protection condition is detected, the starter will write this to the event log and may also trip or issue a warning. The soft starter's response depends on the Protection Action setting (parameter group 6).

Some protection responses cannot be adjusted by the user. These trips are usually caused by external events (such as phase loss) or by a fault within the soft starter. These trips do not have associated parameters and cannot be set to Warn or Log.

If the starter trips you will need to identify and clear the condition that triggered the trip, then reset the starter before restarting. To reset the starter, press the ◀ button on the keypad or activate the Reset remote input.

If the starter has issued a warning, it will reset itself once the cause of the warning has been resolved.

10.2 Trip messages

Display	Possible cause/Suggested solution
2 Phase – Damaged SCR	This message is displayed if the soft starter tripped on “Lx-Tx shorted” during the pre-start checks and PowerThrough is enabled. It indicates that the starter now operates in PowerThrough mode (2-phase control only). Check for either a shorted SCR or short within the bypass contractor. Related parameters: 6S
Battery/clock	A verification error has occurred on the real time clock, or the backup battery voltage is low. If the battery is low and the power is off, date/time settings will be lost. The starter will continue to start and stop correctly. Reprogram the date and time. The battery is not removable. In order to replace the battery, the main control PCB must be replaced. Related parameters: 6T
Bypass overload	This trip is not adjustable. Bypass overload protection protects the soft starter from severe operating overloads while running. The soft starter will trip if it detects overcurrent at 600% of the contactor rating. Related parameters: None

Display	Possible cause/Suggested solution
Current at stop	<p>The starter has detected current at a time when no current is expected (Ready, Not Ready or Tripped states).</p> <ul style="list-style-type: none"> If the motor is connected inside delta (six-wire connection) and no main contactor is installed, a shorted SCR may be passing current to the motor. <p>Related parameters: None</p>
Current imbalance	<p>Current imbalance can be caused by problems with the motor, the environment or the installation, such as:</p> <ul style="list-style-type: none"> An imbalance in the incoming mains voltage A problem with the motor windings A light load on the motor A phase loss on input terminals L1, L2 or L3 during Run mode An SCR that has failed open circuit. A failed SCR can only be definitely diagnosed by replacing the SCR and checking the starter's performance. <p>Related parameters: 5A, 5B, 6C</p>
Current Read Error L1 Current Read Error L2 Current Read Error L3	<p>Internal fault. Contact your local supplier for advice.</p> <p>Related parameters: None</p>
Depth Sensor	<p>The smart card has detected a fault with the depth sensor.</p> <p>Related parameters: 30L, 36C</p>
EEPROM fail	<p>An error occurred loading data from the EEPROM to RAM when the keypad powered up. If the problem persists, contact your local distributor.</p> <p>Related parameters: None</p>
Excess start time	<p>Excess start time trip can occur in the following conditions:</p> <ul style="list-style-type: none"> parameter 1B <i>Motor Full Load Current</i> is not appropriate for the motor parameter 2D <i>Current Limit</i> has been set too low parameter 2B <i>Start Ramp Time</i> has been set greater than the setting for 5O <i>Excess Start Time</i> parameter 2B <i>Start Ramp Time</i> is set too short for a high inertia load when using Adaptive Control <p>Related parameters: 1B, 2B, 2D, 3D, 3F</p>
Firing Fail Px	<p>Where 'X' is phase 1, 2 or 3.</p> <p>The SCR did not fire as expected. The SCR may be faulty or there may be an internal wiring fault.</p> <p>Related parameters: None</p>

TROUBLESHOOTING

Display	Possible cause/Suggested solution
FLC too high	<p>The soft starter can be used on a motor with a higher full load current (FLC) if it is connected inside delta, or if a non-bypassed soft starter is installed with an external bypass contactor.</p> <ul style="list-style-type: none">• If this trip occurs when the soft starter is installed inside delta, the soft starter may not be correctly detecting the connection. Set parameter 20F <i>Motor Connection</i> to 'Inside Delta'.• If the starter is a non-bypassed model and was previously used with an external bypass contactor, but parameter 20G <i>External Bypass</i> has now been set to 'Disable', the FLC may be above the maximum non-bypassed rating. Check that the non-bypassed rating of the soft starter is suitable for the motor, then set parameter 1B <i>Motor Full Load Current</i> to match the motor's FLC. <p>Related parameters: 1B, 20F, 20G</p>
Flow Sensor	<p>The smart card has detected a fault with the flow sensor.</p> <p>Related parameters: 30E, 36B</p>
Flow Switch	<p>The flow switch sensor (smart card terminals C23, C24) has closed.</p> <p>Related parameters: 30E, 36H</p>
Frequency	<p>This trip is not adjustable.</p> <p>The mains frequency has gone beyond the specified range.</p> <p>Check for other equipment in the area that could be affecting the mains supply, particularly variable speed drives and switch mode power supplies (SMPS).</p> <p>If the starter is connected to a generator set supply, the generator may be too small or could have a speed regulation problem.</p> <p>Related parameters: 6O</p>
Ground fault	<p>Test the insulation of the output cables and the motor. Identify and resolve the cause of any ground fault.</p> <p>Related parameters: 40A, 40B, 40C, 40D, 40E</p>
Heatsink overtemperature	<ul style="list-style-type: none">• Check that bypass contactors are operating.• Check that cooling fans are operating (if fitted).• If mounted in an enclosure, check if ventilation is adequate.• The soft starter must be mounted vertically. <p>Related parameters: None</p>

Display	Possible cause/Suggested solution
High Flow	<p>The flow sensor connected to the smart card has activated high flow protection.</p> <p>Related parameters: 30E, 30G, 30H, 31A, 31C, 31D, 36F</p>
High Pressure	<p>The pressure sensor connected to the smart card has activated high pressure protection.</p> <p>Related parameters: 30A, 30C, 30D, 32A, 32B, 32C, 36D</p>
Input A trip Input B trip	<p>The soft starter's programmable input is set to a trip function and has activated. Resolve the trigger condition.</p> <p>Related parameters: 7A, 7B, 7C, 7D, 7E, 7F, 7G, 7H</p>
Instantaneous overcurrent	<p>This trip is not adjustable.</p> <p>The current on all three phases has exceeded 7.2 times the value of parameter 1B <i>Motor Full Load Current</i>.</p> <p>Causes can include a locked rotor condition or an electrical fault in the motor or cabling.</p> <p>Related parameters: None</p>
Internal fault x	<p>Where 'X' is a number.</p> <p>This trip is not adjustable.</p> <p>The starter has tripped on an internal fault. Contact your local supplier with the fault code (X).</p>
Internal fault 88	<p>The soft starter firmware does not match the hardware. This can also indicate high output impedance. Causes include:</p> <ul style="list-style-type: none"> • a long cable run • the motor is not connected • the motor is too small
Keypad disconnected	<p>Parameter 1A <i>Command Source</i> is set to Keypad but the EMX4i cannot detect a remote keypad.</p> <p>If a remote keypad is installed, check the cable is firmly connected to the soft starter.</p> <p>If no remote keypad is installed, change the setting of parameter 1A.</p> <p>Related parameters: 1A</p>

TROUBLESHOOTING

Display	Possible cause/Suggested solution
L1 phase loss	This trip is not adjustable.
L2 phase loss	During pre-start checks the starter has detected a phase loss as indicated.
L3 phase loss	In run state, the starter has detected that the current on the affected phase has dropped below 10% of the programmed motor FLC for more than 1 second, indicating that either the incoming phase or connection to the motor has been lost. Check the supply and the input and output connections at the starter and at the motor end. Related parameters: None
L1-T1 shorted	During pre-start checks the starter has detected a shorted SCR or a short within the bypass contactor as indicated. Consider using 'PowerThrough' to allow operation until the starter can be repaired.
L2-T2 shorted	
L3-T3 shorted	Related parameters: 6S
Low control volts	The starter has detected a drop in the internal control voltage. <ul style="list-style-type: none">• Check the external control supply (A1, A2, A3) and reset the starter. If the external control supply is stable: <ul style="list-style-type: none">• the 24 V supply on the main control PCB may be faulty; or• the bypass driver PCB may be faulty. Contact your local supplier for advice. This protection is not active in Ready state. Related parameters: None
Low Flow	The flow sensor connected to the smart card has activated low flow protection. Related parameters: 30E, 30G, 30H, 31B, 31C, 31D, 36G
Low Pressure	The pressure sensor connected to the smart card has activated low pressure protection. Related parameters: 30A, 30C, 30D, 32D, 32E, 32F, 36E
Low Water	The depth sensor connected to the smart card has activated depth protection. Related parameters: 30L, 30N, 30O, 34A, 34B, 34C, 36I

Display	Possible cause/Suggested solution
Motor connection	This trip is not adjustable.
Motor connection T1	The motor is not connected correctly to the starter.
Motor connection T2	<ul style="list-style-type: none"> • Check individual motor connections to the starter for power circuit continuity.
Motor connection T3	<ul style="list-style-type: none"> • Check connections at the motor terminal box. • If the soft starter is connected to a grounded delta mains supply, adjust parameter 20F <i>Motor Connection</i> to match the motor connection configuration.
Related parameters: 20F	
Motor overload	Overload can be caused by: <ul style="list-style-type: none"> • The starter protection settings not matching the application • Excessive starts per hour or start duration • Excessive current • Damage to the motor windings Resolve the cause of the overload and allow the motor to cool.
Related parameters: 1B, 1F, 1G, 5O, 6J	
	
<p>NOTE</p> <p>Parameter 1F determines the trip current for motor overload protection. The default settings of parameters 1F and 1G provides Motor Overload Protection: Class 10, Trip Current 105% of FLA (full load amperage) or equivalent.</p>	
Motor thermistor	The motor thermistor input has been enabled and: <ul style="list-style-type: none"> • The resistance at the thermistor input has exceeded 3.6 kΩ for more than one second. • The motor winding has overheated. Identify the cause of the overheating and allow the motor to cool before restarting. • The motor thermistor input has been opened. If thermistors have previously been connected to the starter but are no longer required, use the Thermistor Reset function to disable the thermistor.
Related parameters: 6R	

TROUBLESHOOTING

Display	Possible cause/Suggested solution
Network communication	<p>There is a network communication problem, or the network master may have sent a trip command to the starter.</p> <p>Check the network for causes of communication inactivity.</p> <p>Related parameters: 6M</p>
Not ready	<ul style="list-style-type: none">• The reset input may be active. If the reset input is active, the starter will not operate.• The soft starter may be waiting for the restart delay to elapse. The length of the restart delay is controlled by parameter 5P <i>Restart Delay</i>. <p>Related parameters: 5P</p>
Overcurrent	<p>The current has exceeded the level set in parameter 5E <i>Overcurrent</i> for longer than the time set in parameter 5F <i>Overcurrent Delay</i>. Causes can include a momentary overload condition that exceeds the trip threshold.</p> <p>Related parameters: 5E, 5F, 6E</p>
Overpower	<p>The motor has experienced a rise in power. Causes can include a momentary overload condition which has exceeded the adjustable delay time.</p> <p>Related parameters: 5M, 5N, 6I</p>
Overvoltage	<p>A voltage surge, above the set level, occurred on the mains. Causes can include problems with a transformer tap regulator or off-loading of a large transformer load.</p> <p>Related parameters: 5I, 5J, 6G</p>
Parameter out of range	<p>This trip is not adjustable.</p> <ul style="list-style-type: none">• A parameter value is outside the valid range. The keypad will indicate the first invalid parameter.• An error occurred loading data from the EEPROM to RAM when the keypad powered up.• The parameter set or values in the keypad do not match the parameters in the starter.• 'Load User Set' has been selected but no saved file is available. <p>Reset the fault. The starter will load the default settings. If the problem persists, contact your local distributor.</p> <p>Related parameters: None</p>

Display	Possible cause/Suggested solution
Phase sequence	<p>The phase sequence on the soft starter's input terminals (L1, L2, L3) does not match the sequence set in parameter 5R.</p> <p>Check the phase sequence on L1, L2, L3 and ensure the setting in parameter 5R is suitable for the installation.</p> <p>Related parameters: 5R, 6P</p>
Power loss	<p>This trip is not adjustable.</p> <p>The starter is not receiving mains supply on one or more phases.</p> <p>Check that the main contactor closes when a start command is given, and remains closed until the end of a soft stop. Check the fuses. If testing the soft starter with a small motor, it must draw at least 10% of the starter's programmed FLC setting on each phase. If shunt relay mode is enabled (parameter 20H <i>Shunt Trip Mode</i>), certain trips may cause the shunt relay to open the circuit breaker.</p> <p>Related parameters: None</p>
Pressure Sensor	<p>The smart card has detected a fault with the pressure sensor.</p> <p>Related parameters: 30A, 36A</p>
Rating Capacity	<p>The EMX4i is operating beyond its safe capacity. Allow the starter to cool.</p> <p>Related parameters: None</p>
RTD Circuit	<p>The smart card has detected a fault with the RTD sensor, or the RTD has activated temperature protection.</p> <p>Related parameters: 35B, 36J</p>
SCR Itsm	<p>The SCR current surge rating has been exceeded.</p> <p>Related parameters: None</p>
SCR overtemperature	<p>The temperature of the SCRs, calculated by the thermal model, is too high to allow further operation. Wait for the starter to cool.</p> <p>Related parameters: None</p>
Starter communication	<p>There is a problem with the connection between the soft starter and the optional expansion card. Remove and reinstall the card. If the problem persists, contact your local distributor.</p> <p>Related parameters: None</p>

TROUBLESHOOTING

Display	Possible cause/Suggested solution
Starts per hour	<p>The soft starter has already attempted the maximum number of starts in the last 60 minutes. Wait before attempting another start.</p> <p>To determine when the waiting period will end, review the log.</p> <p>Related parameters: 5Q</p>
Thermistor circuit	<p>The thermistor input has been enabled and:</p> <ul style="list-style-type: none">• The resistance at the input has fallen below 20 Ω (the cold resistance of most thermistors will be over this value) or• A short circuit has occurred. Check and resolve this condition. <p>Related parameters: None</p>
Time-overcurrent	<p>The EMX4i is internally bypassed and has drawn high current during running. (The 10A protection curve trip has been reached or the motor current has risen to 600% of the motor FLC setting.)</p> <p>Related parameters: None</p>
Undercurrent	<p>Motor current has fallen below the level selected. This is usually due to a reduced load. Causes can include broken components (shafts, belts or couplings), or a pump running dry.</p> <p>Related parameters: 5C, 5D, 6D</p>
Underpower	<p>Motor power has fallen below the level selected. This is usually due to a reduced load. Causes can include broken components (shafts, belts or couplings), or a pump running dry.</p> <p>Related parameters: 5K, 5L, 6H</p>
Undervoltage	<p>Mains voltage has fallen below the level selected. Causes can include an undersized supply or adding a large load to the system.</p> <p>Related parameters: 5G, 5H, 6F</p>
Unsupported option	<p>The selected function is not available (eg jog is not supported in inside delta configuration).</p> <p>Related parameters: None</p>
VZC Fail Px	<p>Where 'X' is 1, 2 or 3.</p> <p>Internal fault (PCB fault). Contact your local supplier for advice.</p> <p>Related parameters: None</p>

Display	Possible cause/Suggested solution
Zero Speed Detect	<p>The zero speed input has not closed within the expected duration of a soft stop.</p> <ul style="list-style-type: none">• Check the zero speed sensor is operating correctly.• Check that parameters <i>2Q Brake Current Limit</i> and <i>5O Excess Start Time</i> are appropriate for the application. <p>Related parameters: 2Q, 3S, 5O</p>

10.3 General faults

This table describes situations where the soft starter does not operate as expected but does not trip or give a warning.

General Faults

Symptom	Probable cause/Solution
Starter 'Not Ready'	<ul style="list-style-type: none"> The reset input may be active. If the reset input is active, the starter will not operate.
'Simul' on display	<ul style="list-style-type: none"> The starter is running simulation software. This software is intended for demonstration purposes only and is not suitable for controlling a motor. Contact your local supplier for advice.
The soft starter does not respond to the START or RESET button on the remote keypad.	<ul style="list-style-type: none"> The soft starter will only accept commands from the keypad if parameter 1A <i>Command Source</i> is set to Keypad. Check that the Local LED on the starter is on.
The starter does not respond to commands from the digital inputs.	<ul style="list-style-type: none"> The soft starter will only accept commands from the inputs if parameter 1A <i>Command Source</i> is set to Digital Input. Check the setting of 1A. The control wiring may be incorrect. Check that the remote start, stop and reset inputs are configured correctly (see <i>Start/stop</i> on page 49 for details). The signals to the remote inputs may be incorrect. Test the signalling by activating each input signal in turn.
The soft starter does not respond to a start command from either the keypad or the digital inputs.	<ul style="list-style-type: none"> The soft starter may be waiting for the restart delay to elapse. The length of the restart delay is controlled by parameter 5P <i>Restart Delay</i>. The motor may be too hot to permit a start. The soft starter will only permit a start when it calculates that the motor has sufficient thermal capacity to complete the start successfully. Wait for the motor to cool before attempting another start. The reset input may be active. If the reset input is active, the starter will not operate. The soft starter may be waiting for control signals via the communication network (parameter 1A <i>Command Source</i> = Network). The EMX4i may be waiting for a scheduled auto-start (parameter 1A <i>Command Source</i> = Clock).
Erratic and noisy motor operation.	<ul style="list-style-type: none"> If the soft starter is connected to the motor using inside delta configuration, the soft starter may not

Symptom	Probable cause/Solution
	be correctly detecting the connection. Contact your local supplier for advice.
Remote keypad shows message "awaiting data"	The keypad is not receiving data from the control PCB. Check the cable connection.
The soft starter does not control the motor correctly during starting.	<ul style="list-style-type: none"> • Start performance may be unstable when using a low <i>Motor Full Load Current</i> setting (parameter 1B). • Power factor correction (PFC) capacitors must be installed on the supply side of the soft starter and must be disconnected during starting and stopping. To use the starter to control power factor correction, connect the PFC contactor to a programmable relay set to 'Run'. • High levels of harmonics on the mains supply can affect soft starter performance. If variable speed drives are installed nearby, check they are properly grounded and filtered.
Motor does not reach full speed.	<ul style="list-style-type: none"> • If the start current is too low, the motor will not produce enough torque to accelerate to full speed. The soft starter may trip on excess start time.
	<p data-bbox="596 1108 647 1180"> NOTE</p> <p data-bbox="676 1160 1369 1413">Make sure the motor starting parameters are appropriate for the application and that you are using the intended motor starting profile. If a programmable input is set to 'Motor Set Select', check that the corresponding input is in the expected state.</p> <ul style="list-style-type: none"> • The load may be jammed. Check the load for severe overloading or a locked rotor situation.
Soft stop ends too quickly.	<ul style="list-style-type: none"> • The soft stop settings may not be appropriate for the motor and load. Review the soft stop settings. • If the motor is very lightly loaded, soft stop will have limited effect.
After selecting Adaptive Control the motor used an ordinary start and/or the second start was different to the first.	<ul style="list-style-type: none"> • The first Adaptive Control start is actually 'Constant Current' so that the starter can learn from the motor characteristics. Subsequent starts use Adaptive Control.

TROUBLESHOOTING

Symptom	Probable cause/Solution
'PowerThrough' does not operate when selected.	<ul style="list-style-type: none">• The starter will trip on Lx-Tx Shorted on the first start attempt after control power is applied. PowerThrough will not operate if control power is cycled between starts.
Parameter settings cannot be stored.	<ul style="list-style-type: none">• Make sure you are saving the new value by pressing ▶ after adjusting a parameter setting. If you press ◀, the change will not be saved. The EMX4i does not display a confirmation.• Check that the adjustment lock (parameter 10G) is set to Read & Write. If the adjustment lock is set to Read Only, settings can be viewed but not changed.
USB Full	<ul style="list-style-type: none">• The USB drive may not have enough free space available for the selected function.• The file system on the USB drive may not be compatible with the soft starter. The EMX4 supports FAT32 file systems. The EMX4's USB functions are not compatible with NTFS file systems.
USB Missing	A USB function has been selected in the menu, but the product cannot detect a USB drive. Check that the USB drive has been inserted in the port.
File Missing	A USB function has been selected in the menu, but the required file cannot be found. Save/Load Master Parameters uses a file called Master_Parameters.par, at the top level of the USB drive. For these functions to work correctly, do not move or rename this file.
File Not Valid	A USB function has been selected in the menu, but the file is not valid.
File Empty	A USB function has been selected in the menu and the file has been found, but does not contain the expected content.
'Rating Not Valid'	The value of parameter 20D <i>Model Rating</i> is incorrect. Parameter 20D is not user-adjustable. Contact your local supplier for advice.



BENSHAW
Applied Motor Controls

BENSHAW
615 Alpha Drive
Pittsburgh, PA 15238
Phone: (412) 968-0100
Fax: (412) 968-5415

BENSHAW Canada
550 Bright Street
Listowel, Ontario N4W 3W3
Phone: (519) 291-5112
Fax: (519) 291-2595



7 10-21919-00D