

TOP VIEW

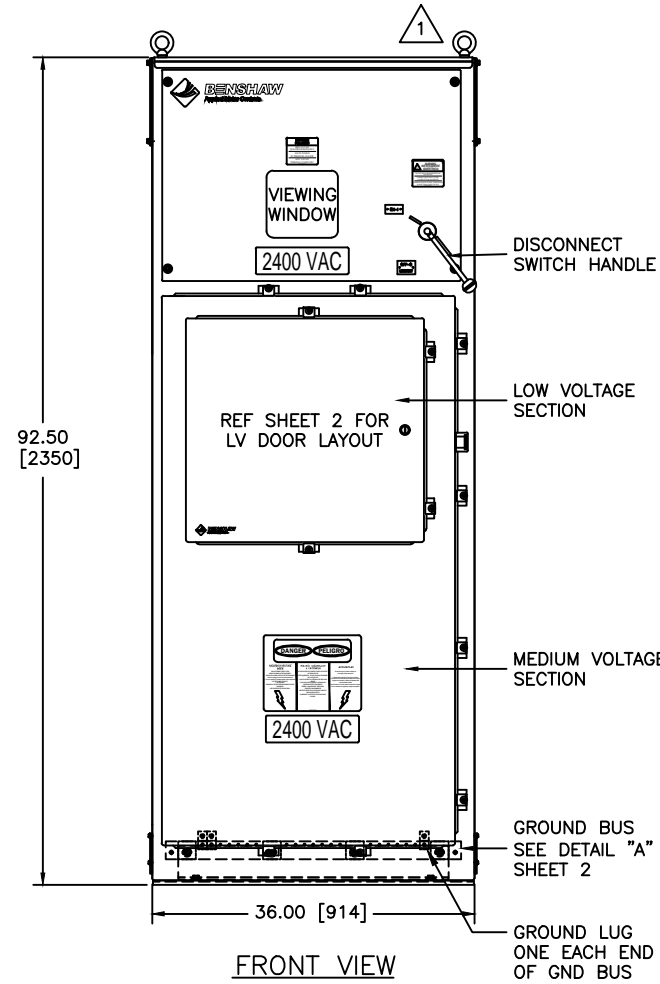

FRONT VIEW

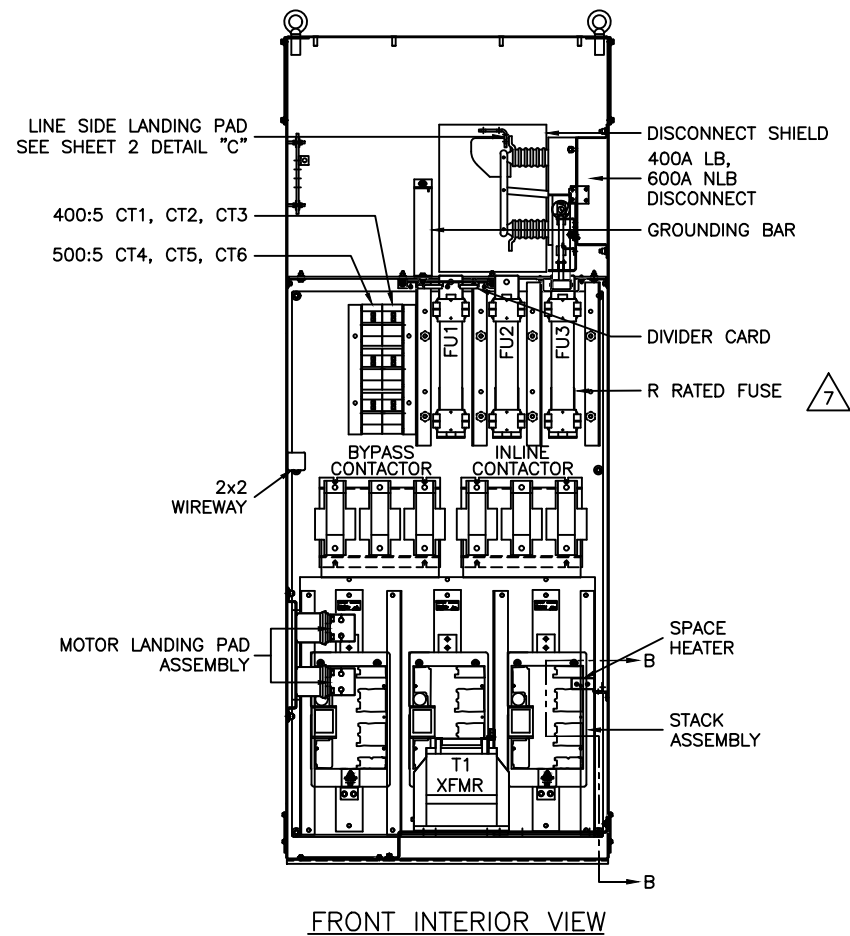

FRONT INTERIOR VIEW

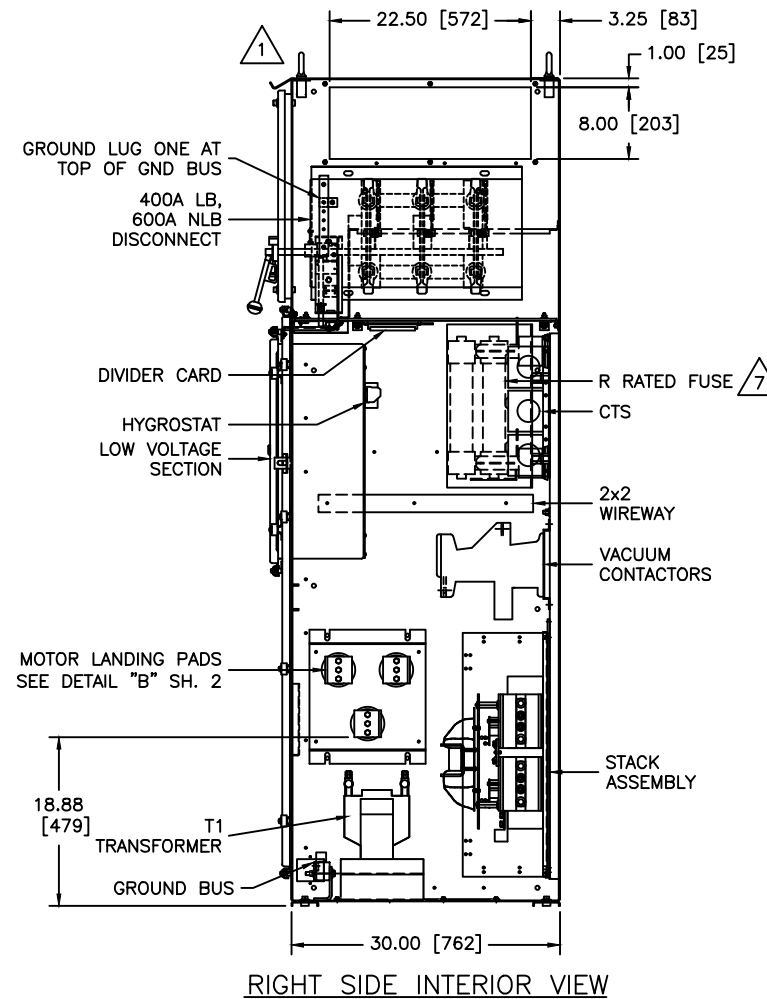

RIGHT SIDE INTERIOR VIEW

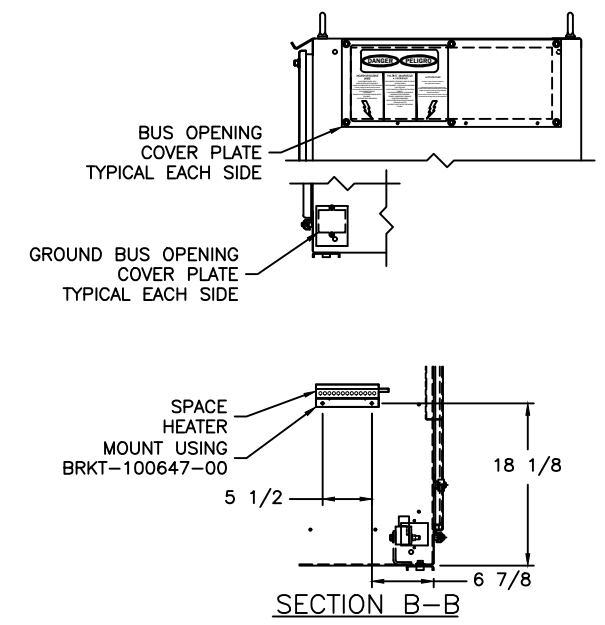

SECTION B-B

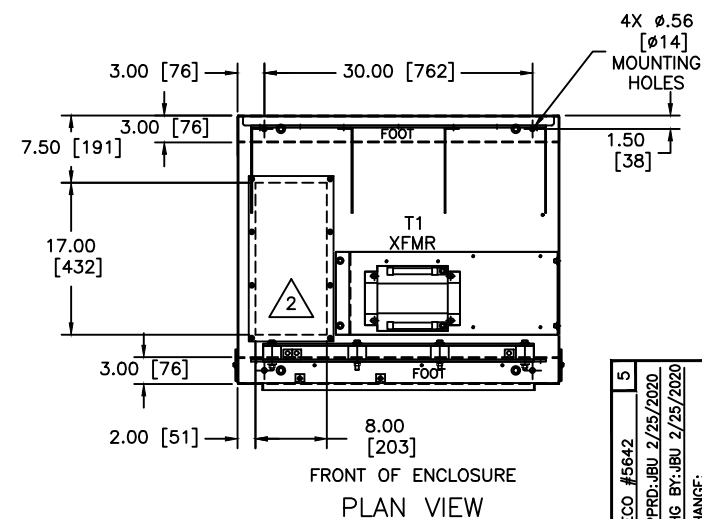

FRONT OF ENCLOSURE PLAN VIEW

- NOTES:
- 1 REMOVABLE LIFTING EYEBOLTS
  - 2 CABLE ENTRY/EXIT AREA. CUTOUT W/ COVER PLATE SUPPLIED
  - 3 CABLE ENTRY/EXIT AREA. NO CUTOUT SUPPLIED. CUSTOMER TO CUT AS REQUIRED.
  - 4 ENCLOSURE COLOR: ANSI 61 GREY
  - 5 TIGHTEN BOLTS PER CHART BELOW

STEEL BOLT TORQUE IN POUND-FOOT [NEWTON-METER]				
1/4-20	5/16-18	3/8-16	1/2-13	5/8-11
5 [6.8]	12 [16.3]	20 [27]	50 [67.8]	95 [128.8]

- 6 APPROXIMATE WEIGHT IS 1600LBS [726KG]
- 7 R-FUSES SHOWN FOR REFERENCE. REFERENCE SALES ORDER FOR FUSE SIZE.

ECO #5642 APPRD:JBU 2/25/2020 CHG BY:JBU 2/25/2020 CHANGE: UL 347 UPDATE	ECO #529B APPRD:SMW 11/29/17 CHG BY:RBW 11/29/17 CHANGE: REVISED PER ECO.	ECO #529B APPRD:JBU 7/7/16 CHG BY:JBU 7/7/16 CHANGE: GENERAL UPDATE	REVISION DO NOT SCALE DWG	THIRD ANGLE PROJECTION THIS DRAWING AND ALL INFORMATION CONTAINED HEREIN, IS THE PROPERTY OF BENSCHAW INC., AND MAY NOT BE REPRODUCED, OR DWLUGED TO UNAUTHORIZED PERSONS WITHOUT THE EXPRESS WRITTEN CONSENT OF BENSCHAW INC. IT IS PROVIDED SOLELY FOR THE CONVENIENCE OF THE USER AND SHALL BE RETURNED UPON REQUEST.	UNLESS OTHERWISE SPECIFIED ALL DIMENSIONS IN INCHES [mm] INTERPRET DRAWING PER ASME Y14.5M-1994 TOLERANCES: .XX ± .03 .XXX ± .015 ANGLES ± 1°	SIGNATURES DRWN. JBU 5/26/16 CHKD. ENG. JBU 5/26/16	DATE 5/26/16	TITLE: UL LABELED CFMVRMX12-1500-2300-3R SOLID STATE STARTER ENCLOSURE LAYOUT	815 ALPHA DRIVE PITTSBURGH, PA 15238 550 BRIGHT ST. E. LISTON, ONTARIO M4W 3K2	SCALE: 3/32 : 1 SHEET 1 OF 7	REV 5
						SIZE DWG. NO. D MVRXE12150023003R					

**CUSTOMER TERMINAL BLOCKS**

6	REMOTE E-STOP
6C	REMOTE E-STOP
6B	REMOTE E-STOP
65	START/STOP COMMAND CUSTOMER SUPPLIED
66	START/STOP COMMAND CUSTOMER SUPPLIED
80	FAULT INDICATION IN S.S. MODE FOR CUSTOMER USE
81	FAULT INDICATION IN S.S. MODE FOR CUSTOMER USE
82	FAULT INDICATION IN S.S. MODE FOR CUSTOMER USE
83	UP-TO-SPEED INDICATION IN S.S. MODE FOR CUSTOMER USE
84	UP-TO-SPEED INDICATION IN S.S. MODE FOR CUSTOMER USE
85	UP-TO-SPEED INDICATION IN S.S. MODE FOR CUSTOMER USE
86	RUN INDICATION IN ATL & S.S. MODES FOR CUSTOMER USE
87	RUN INDICATION IN ATL & S.S. MODES FOR CUSTOMER USE
88	RUN INDICATION IN ATL & S.S. MODES FOR CUSTOMER USE
92	ANALOG OUTPUT FOR CUSTOMER USE
93	ANALOG OUTPUT FOR CUSTOMER USE
94	ANALOG OUTPUT FOR CUSTOMER USE
95	O/L FAULT IND. IN ATL MODE FOR CUSTOMER USE
96	O/L FAULT IND. IN ATL MODE FOR CUSTOMER USE
97	O/L FAULT IND. IN ATL MODE FOR CUSTOMER USE
98	RS-485
99	RS-485
SHD	
SP	
SP	
SP	

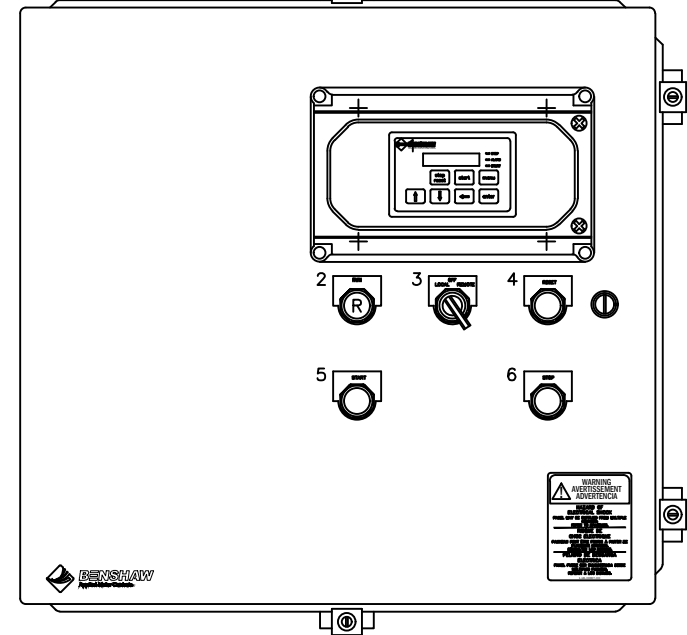

- DEVICE LEGEND**
1. KEYPAD DISPLAY WITH 3R COVER
  2. "RUN" (RED) PILOT LIGHT
  3. "LOCAL-OFF-REMOTE" SELECTOR SWITCH
  4. "RESET" (BLACK) PUSHBUTTON
  5. "START" (GREEN) PUSHBUTTON
  6. "STOP" (RED) RAISED PUSHBUTTON

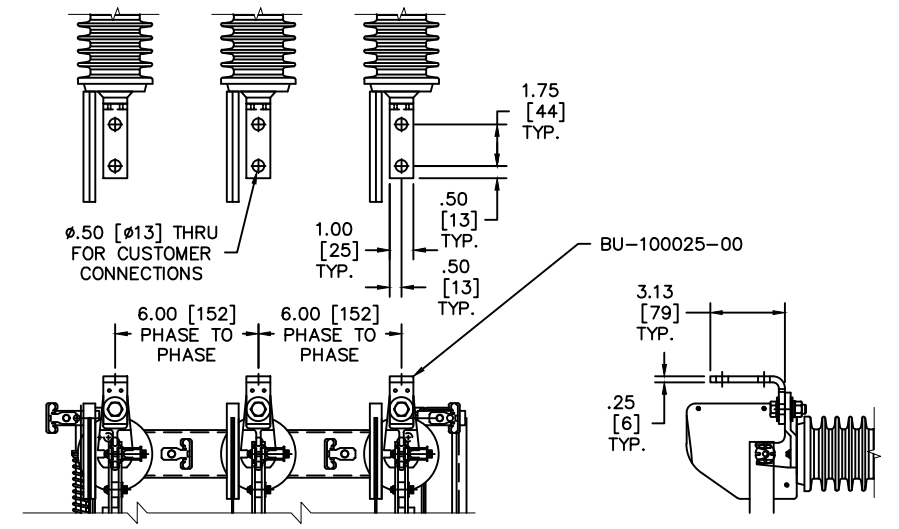

**BENSHAW TERMINAL BLOCKS**

4
5A
6
6
6B
6B
6B
7
7
7
7
7
7
7
7
5
5
10
10
13
36
41
42
43
44
51
52
SP
SP
SP
SP

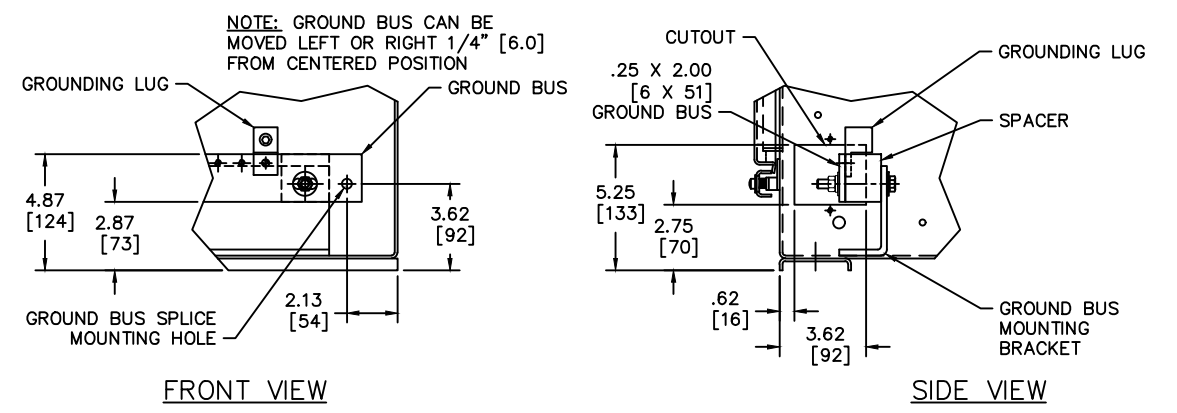
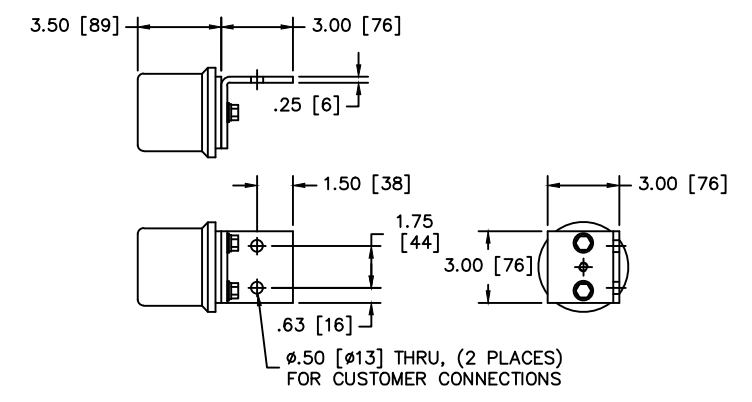
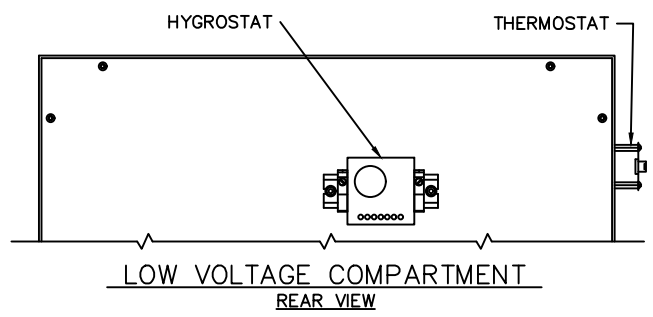
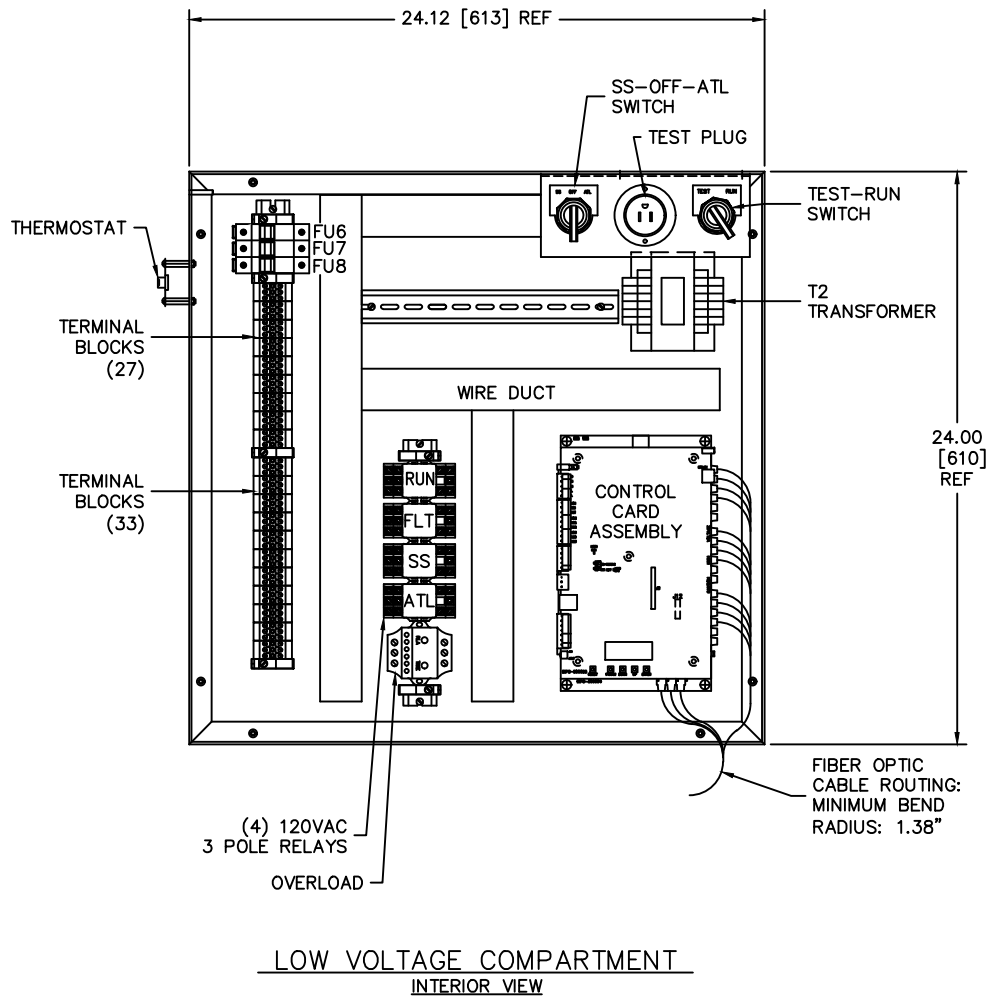

5	ECO #5642	APPRD: JBU 2/25/2020	CHG BY: JBU 2/25/2020	CHANGE: UL 347 UPDATE	4	ECO #5298	APPRD: SHM 11/29/17	CHG BY: RBM 11/29/17	CHANGE: REVISED PER ECO.	3	APPRD: JBU 7/8/16	CHG BY: JBU 7/8/16	CHANGE: GENERAL UPDATE	2	APPRD: JBU 6/2/16	CHG BY: JBU 6/2/16	CHANGE: CORRECT LV DOOR	1	APPRD: JBU 5/26/16	CHG BY: JBU 5/26/16	CHANGE: GENERAL UPDATE	REVISION	DO NOT SCALE DWG	THIRD ANGLE PROJECTION	UNLESS OTHERWISE SPECIFIED ALL DIMENSIONS IN INCHES [mm] INTERPRET DRAWING PER ASME Y14.5M-1994	TOLERANCES: .XX ± .03 .XXX ± .015 ANGLES ± 1°	MATERIAL: FINISH:	SIGNATURES	DATE	TITLE: UL LABELED CFMVRMX12-1500-2300-3R SOLID STATE STARTER LOW VOLTAGE COMPARTMENT AND ENCLOSURE DETAILS	SCALE: 1/4 : 1	SHEET 2 OF 7	REV 5
																							D MVRXE12150023003R										



SHOP NOTES:

- S1 ALL INSTRUMENT AND CONTROL GROUND WIRES ARE #12AWG GREEN WIRE, EXCEPT WHERE NOTED, RUN SEPARATELY TO GROUND LUG POINT. DO NOT DAISY CHAIN GROUND WIRES. RUN ALL GROUND WIRES A MINIMUM OF FOUR (4) INCHES FROM POWER CABLE AND HEATSINKS.
- S2 ALL SECONDARY POWER WIRING MUST BE ROUTED SEPARATE FROM GROUND WIRES AND CONTROL WIRING.
- S3 ALL CURRENT TRANSFORMER SIGNAL WIRING TO BE COVERED WITH HIGH VOLTAGE SLEEVING. ALL CURRENT TRANSFORMERS TO BE SEPARATELY GROUNDED TO GROUND BUS.
- S4 ALL WIRING IN THE MEDIUM VOLTAGE AREA WITHIN FOUR (4) INCHES OF THE HEATSINK ASSEMBLY OR POWER CABLE MUST HAVE 5KV SLEEVING.
- S5 SEPARATE LOW VOLTAGE SUPPLY & CONTROL WIRING AS MUCH AS POSSIBLE FROM MV WIRING. MINIMUM SPACE IS 3". WIRES TO CROSS AT 90° ANGLES.
- S6 14AWG GREEN WIRE, EXCEPT WHERE OTHERWISE NOTED, RUN SEPARATELY TO GROUND LUG POINT. DO NOT DAISY CHAIN GROUND WIRES. RUN ALL GROUND WIRES A MINIMUM OF FOUR (4) INCHES FROM POWER CABLE AND HEATSINKS.
- S7 SCR GATE WIRES TO BE COVERED WITH HIGH VOLTAGE SLEEVING.
- S8 ALL CONTROL WIRING TO BE 14AWG EXCEPT WHERE NOTED.

PARAMETER SETTINGS  
SEE MANUAL FOR ADDITIONAL SETTINGS

GROUP	DISPLAY	FUNCTION	AS BUILT
QST 04	LOCAL SRC	LOCAL START SOURCE	TERMINAL
QST 05	REMOTE SRC	REMOTE START SOURCE	TERMINAL
I/O/ 26	Kpd Stop	KEYPAD STOP ENABLE / DISABLE	DISABLE
I/O/ 01	DI 1 CONFIG	DIGITAL INPUT #1 CONFIGURATION	OFF
I/O/ 02	DI 2 CONFIG	DIGITAL INPUT #2 CONFIGURATION	INLINE CNFRM
I/O/ 03	DI 3 CONFIG	DIGITAL INPUT #3 CONFIGURATION	DISCONNECT
I/O/ 04	DI 4 CONFIG	DIGITAL INPUT #4 CONFIGURATION	FAULT LOW
I/O/ 05	DI 5 CONFIG	DIGITAL INPUT #5 CONFIGURATION	OFF
I/O/ 06	DI 6 CONFIG	DIGITAL INPUT #6 CONFIGURATION	FAULT RESET
I/O/ 07	DI 7 CONFIG	DIGITAL INPUT #7 CONFIGURATION	OFF
I/O/ 08	DI 8 CONFIG	DIGITAL INPUT #8 CONFIGURATION	OFF
I/O/ 10	R1 CONFIG	RELAY OUTPUT #1 CONFIGURATION	FAULT FS
I/O/ 11	R2 CONFIG	RELAY OUTPUT #2 CONFIGURATION	UTS
I/O/ 12	R3 CONFIG	RELAY OUTPUT #3 CONFIGURATION	RUNNING
I/O/ 13	R4 CONFIG	RELAY OUTPUT #4 CONFIGURATION	OFF
I/O/ 14	R5 CONFIG	RELAY OUTPUT #5 CONFIGURATION	OFF
I/O/ 15	R6 CONFIG	RELAY OUTPUT #6 CONFIGURATION	OFF
I/O/ 21	Aout Fctn	ANALOG OUTPUT FUNCTION	OFF
RTD 01	RTDMod1 Addr	RTD MODULE #1 ADDRESS	OFF
RTD 02	RTDMod2 Addr	RTD MODULE #2 ADDRESS	OFF

- STANDARD LEGEND
- WIRE NODE SYMBOL
  - BENSRAW SUPPLIED TERMINAL BLOCK
  - POWER CONNECTION
  - TWISTED PAIR
  - TWISTED, SHIELDED PAIR
  - SHIELDED
  - FIBER OPTIC CABLE  
ARROW INDICATES DIRECTION OF SIGNAL
  - (C-3) UNDERLINED CONTACT REFERENCES ARE NORMALLY CLOSED
  - (C-3) NORMALLY OPENED CONTACT REFERENCES ARE NOT UNDERLINED

GROUP	DISPLAY	FUNCTION	AS BUILT
FUN 03	CT RATIO	CT RATIO	400:5
FUN 05	RATED VOLTS	RATED RMS VOLTAGE	2300
FUN 07	STARTER TYPE	STARTER TYPE	NORMAL
FUN 20	STACK OL	STACK OL ENABLE / DISABLE	ENABLE
FUN 21	STACK RATING	STACK RATING	360A

	SOFTWARE VERSION	MANUAL
MX3 CARD	810023-02-xx	890034-03-xx
MVIO CARD	810024-01-xx	

xx VERSION AT TIME OF SHIPMENT

CUSTOMER NOTES:

- C1 ITEM LOCATED IN STARTER MEDIUM VOLTAGE SECTION.
- C2 ITEM LOCATED IN STARTER LOW VOLTAGE SECTION.
- C3 R1 RELAY SHOWN IN DE-ENERGIZED STATE. R1 N.O. CONTACT WILL OPEN AND R1 N.C. CONTACT WILL CLOSE ON SYSTEM FAULT. R1 RELAY INDICATES FAULT ON POWER-UP UNTIL STARTER SELF-CHECK IS COMPLETE.
- C4 LED STATUS WITH POWER APPLIED.  
 "ON" "OFF"
- C5 REMOVE REMOTE RUN COMMAND PRIOR TO RESETTING A FAULT TO PREVENT IMMEDIATE RESTART OF THE MOTOR.
- C6 REFERENCE SALES ORDER FOR R-FUSE SIZE.
- C7 THE ACTUAL HP AND FLA RATINGS VARY PER MOTOR. SIZE R-FUSES PER MOTOR FLA. THE MAXIMUM SIZE R-FUSE FOR THIS MODEL MVRXE IS 24R.

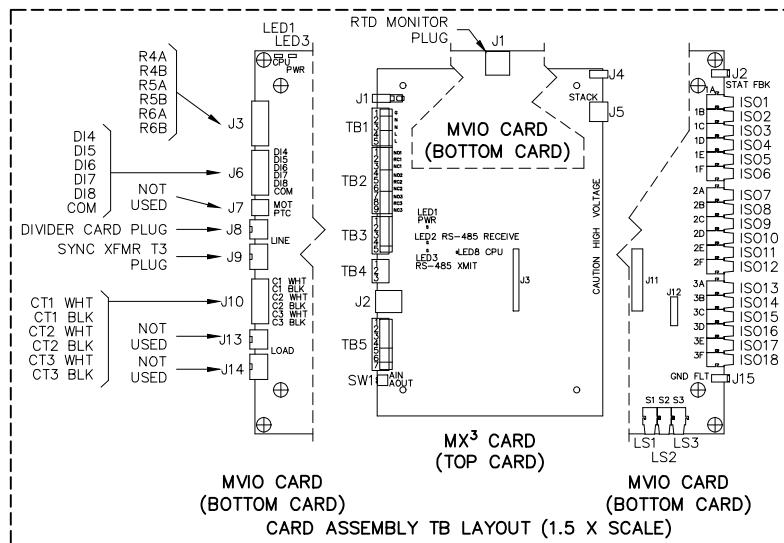

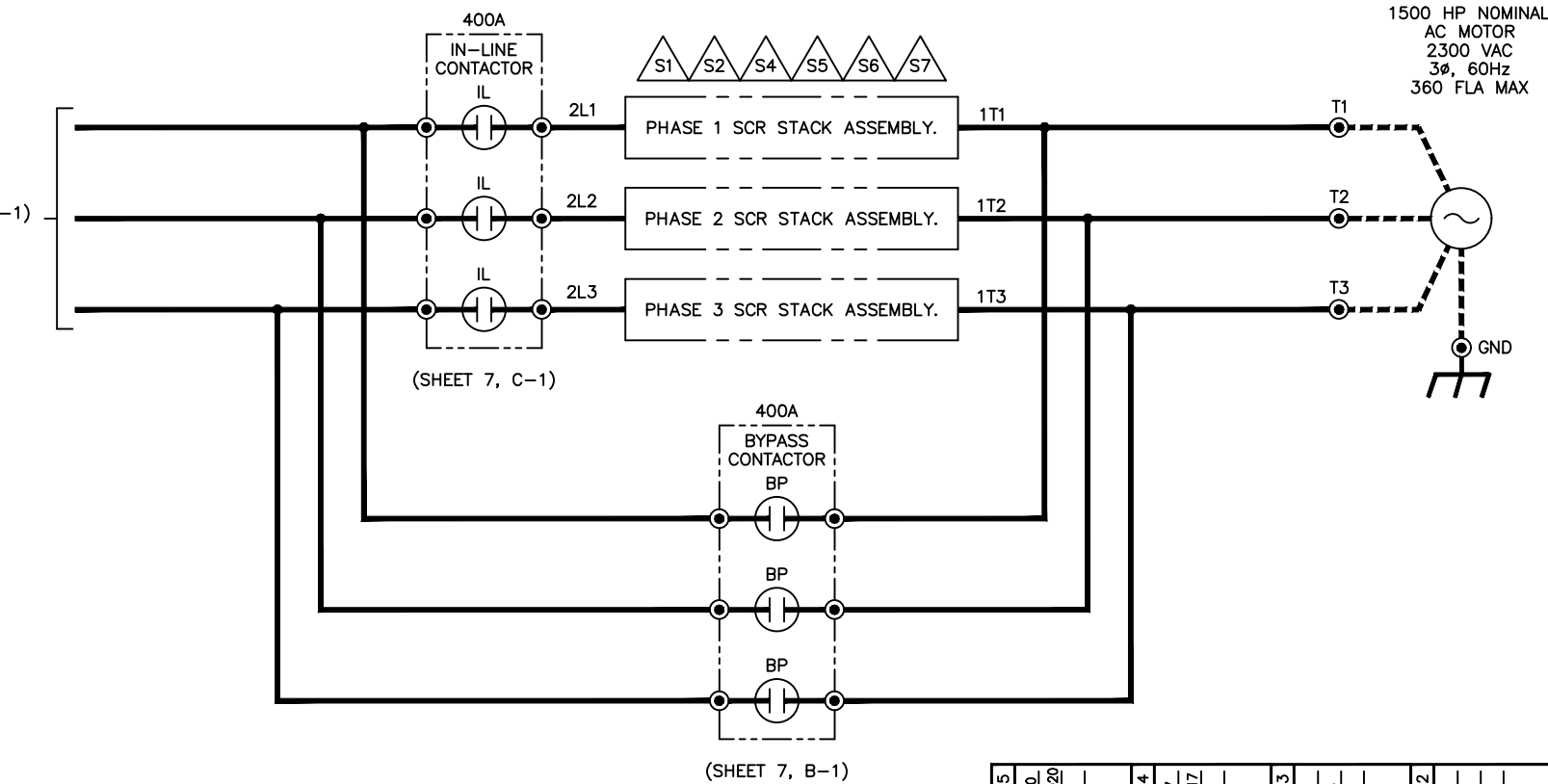
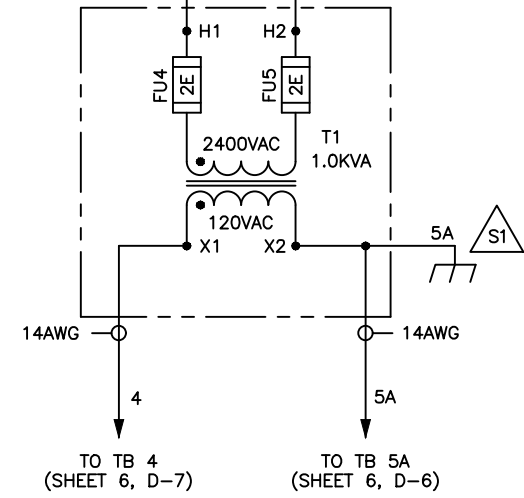
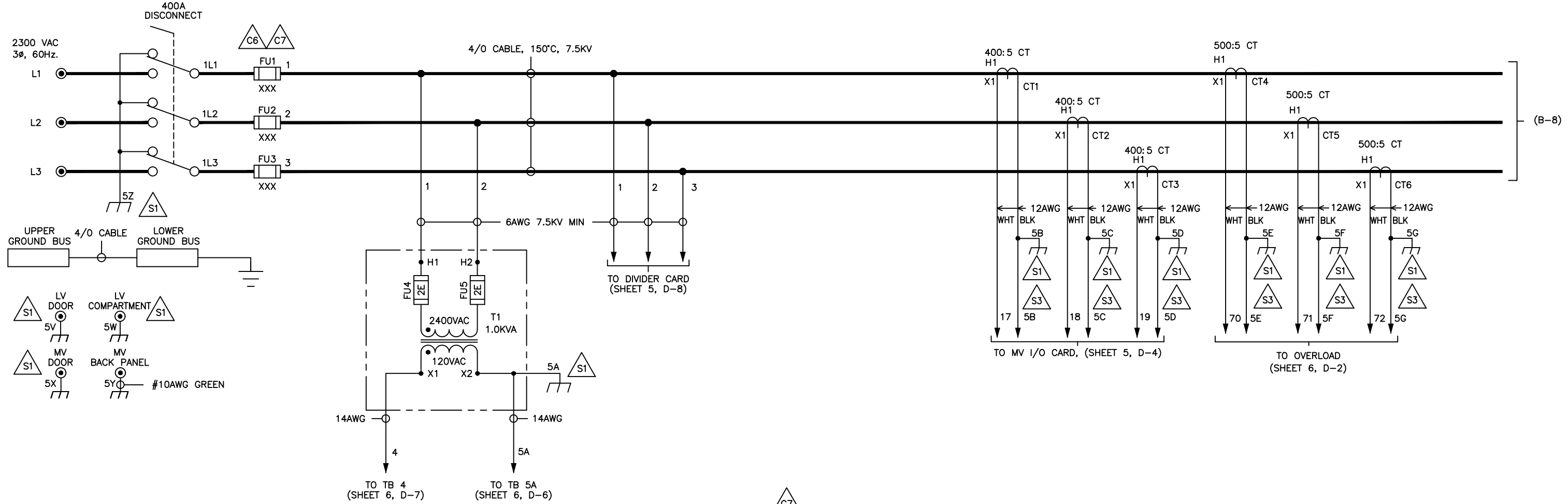

**CAUTION:**  
SEVERE DAMAGE MAY RESULT IF SURGE CAPACITORS, LIGHTNING ARRESTERS, OR POWER FACTOR CORRECTION CAPACITORS ARE CONNECTED TO THE LOAD SIDE OF THE SOLID STATE STARTER. CONSULT FACTORY BEFORE USING ANY OF THESE POWER QUALITY ENHANCEMENT DEVICES.

5 ECO #5642 APPRD: JBU 2/25/2020 CHG BY: JBU 2/25/2020 CHANGE: UL 347 UPDATE	4 ECO #5298 APPRD: SMM 11/29/17 CHG BY: RBM 11/29/17 CHANGE: REVISED PER ECO.	3 APPRD: JBU 7/11/16 CHG BY: JBU 7/11/16 CHANGE: GENERAL UPDATE	2 APPRD: JBU 6/2/16 CHG BY: JBU 6/2/16 CHANGE: SHEET 2	1 APPRD: JBU 5/26/16 CHG BY: JBU 5/26/16 CHANGE: GENERAL UPDATE	REVISION DO NOT SCALE DWG	THIRD ANGLE PROJECTION	UNLESS OTHERWISE SPECIFIED ALL DIMENSIONS IN INCHES [mm] INTERPRET DRAWING PER ASME Y14.5M-1994 TOLERANCES: .XX $\pm$ .03 .XXX $\pm$ .015 ANGLES $\pm$ 1'	SIGNATURES DRWN: JBU 5/26/16 CHKD: ENG: JBU 5/26/16	DATE 5/26/16	TITLE: UL LABELED CFMVRMX12-1500-2300-3R SOLID STATE STARTER SCHEMATIC	SEE SHEET 3 FOR NOTES	BENSHAW 815 ALPHA DRIVE PITTSBURGH, PA. 15238	550 BRIGHT ST. E. LONDON, ONTARIO N4W 3K2	SCALE: N.A.	SHEET 4 OF 7	REV 5
---	--	---	--	---	------------------------------	------------------------	---	--	-----------------	---	-----------------------	---	---	-------------	--------------	-------

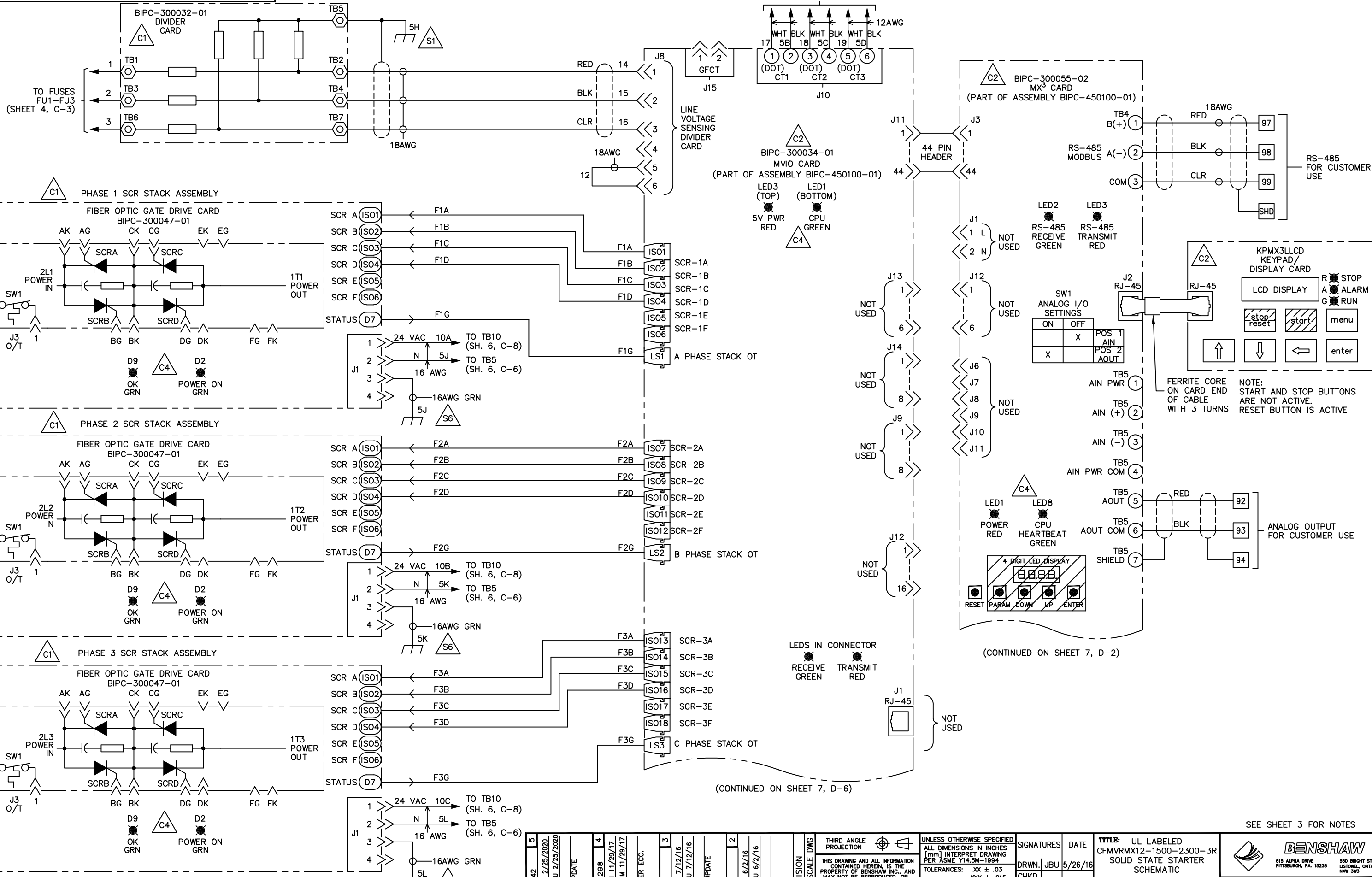

(CONTINUED ON SHEET 7, D-6)

(CONTINUED ON SHEET 7, D-2)

5	ECO #5642	APPRD: JBU 2/25/2020	CHG BY: JBU 2/25/2020	CHANGE: UL 347 UPDATE	4	ECO #5298	APPRD: SMH 11/29/17	CHG BY: RBM 11/29/17	CHANGE: REVISED PER ECO.	3	APPRD: JBU 7/12/16	CHG BY: JBU 7/12/16	CHANGE: GENERAL UPDATE	2	APPRD: JBU 6/2/16	CHG BY: JBU 6/2/16	CHANGE: SHEET 2	REVISION	DO NOT SCALE DWG	THIRD ANGLE PROJECTION	UNLESS OTHERWISE SPECIFIED ALL DIMENSIONS IN INCHES [mm] INTERPRET DRAWING PER ASME Y14.5M-1994 TOLERANCES: .XX ± .03 .XXX ± .015 ANGLES ± 1°	MATERIAL: FINISH:	SIGNATURES	DATE	TITLE: UL LABELED CFMVRMX12-1500-2300-3R SOLID STATE STARTER SCHEMATIC	SCALE: N.A.	SHEET 5 OF 7	REV 5
																		D MVRXE12150023003R										

SEE SHEET 3 FOR NOTES



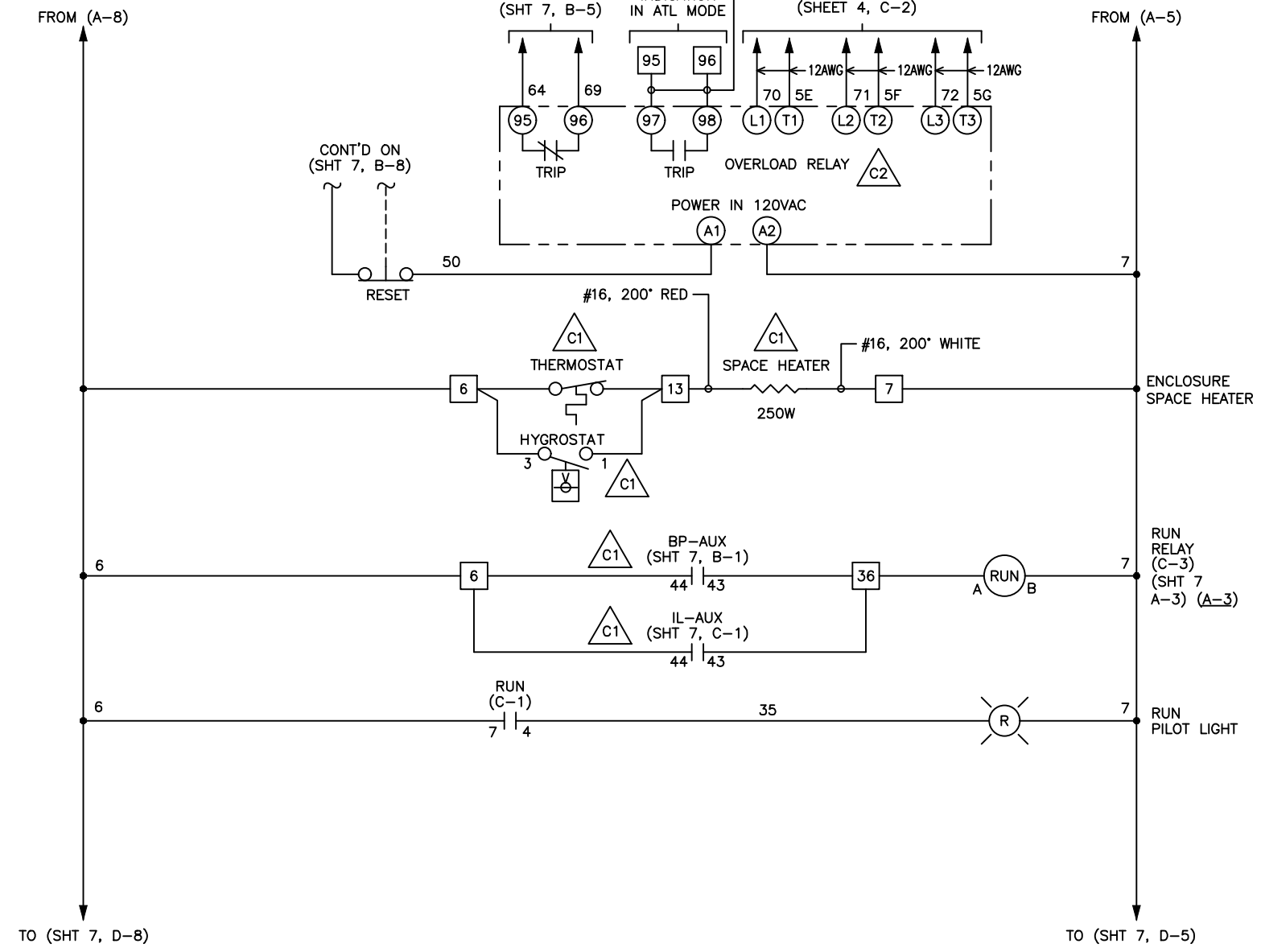
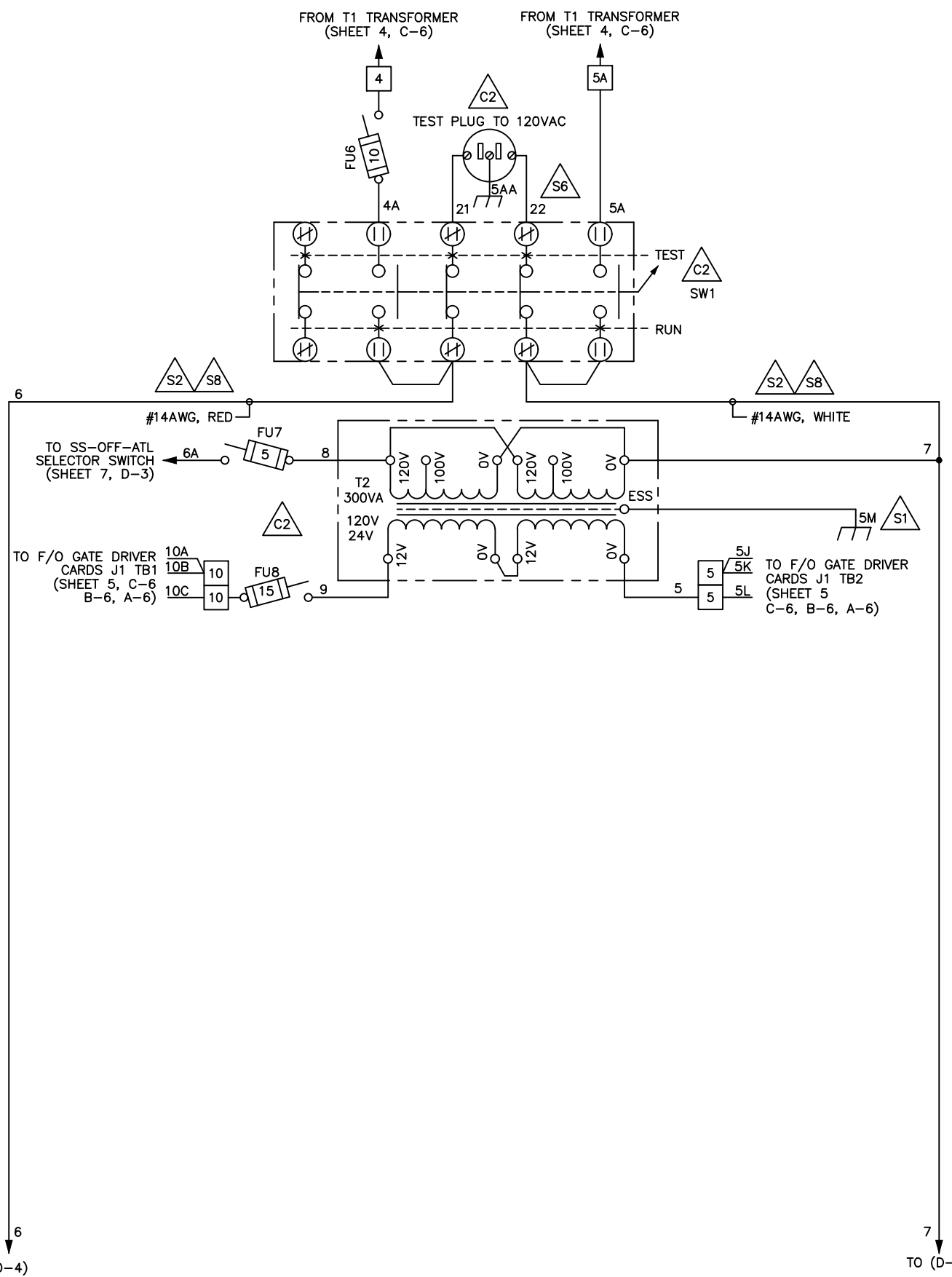

5 ECO #5642 APPRD: JBU 2/25/2020 CHG BY: JBU 2/25/2020 CHANGE: UL 347 UPDATE	4 ECO #5298 APPRD: SMM 11/29/17 CHG BY: RBM 11/29/17 CHANGE: REVISED PER ECO.	3 APPRD: JBU 7/13/16 CHG BY: JBU 7/13/16 CHANGE: GENERAL UPDATE	2 APPRD: JBU 6/2/16 CHG BY: JBU 6/2/16 CHANGE: SHEET 2	1 APPRD: JBU 5/26/16 CHG BY: JBU 5/26/16 CHANGE: GENERAL UPDATE	REVISION DO NOT SCALE DWG THIRD ANGLE PROJECTION THIS DRAWING AND ALL INFORMATION CONTAINED HEREIN IS THE PROPERTY OF BENSCHAW INC. AND MAY NOT BE REPRODUCED, OR DIVULGED TO UNAUTHORIZED PERSONS, WITHOUT THE EXPRESS WRITTEN CONSENT OF BENSCHAW INC. IT IS PROVIDED SOLELY FOR THE CONVENIENCE OF THE USER AND SHALL BE RETURNED UPON REQUEST.	UNLESS OTHERWISE SPECIFIED ALL DIMENSIONS IN INCHES [mm] INTERPRET DRAWING PER ASME Y14.5M-1994 TOLERANCES: .XX ± .03 .XXX ± .015 ANGLES ± 1° MATERIAL: FINISH:	SIGNATURES DRWN. JBU 5/26/16 CHKD. ENG. JBU 5/26/16 DATE DATE	TITLE: UL LABELED CFMVRMX12-1500-2300-3R SOLID STATE STARTER SCHEMATIC SCALE: N.A. SHEET 6 OF 7	SEE SHEET 3 FOR NOTES BENSCHAW 815 ALPHA DRIVE PITTSBURGH, PA. 15238 550 BRIGHT ST. E. LISTON, ONTARIO N4W 3K2	SIZE DWG. NO. D MVRXE12150023003R REV 5
---	--	---	--	---	---	---	--	--	---	---

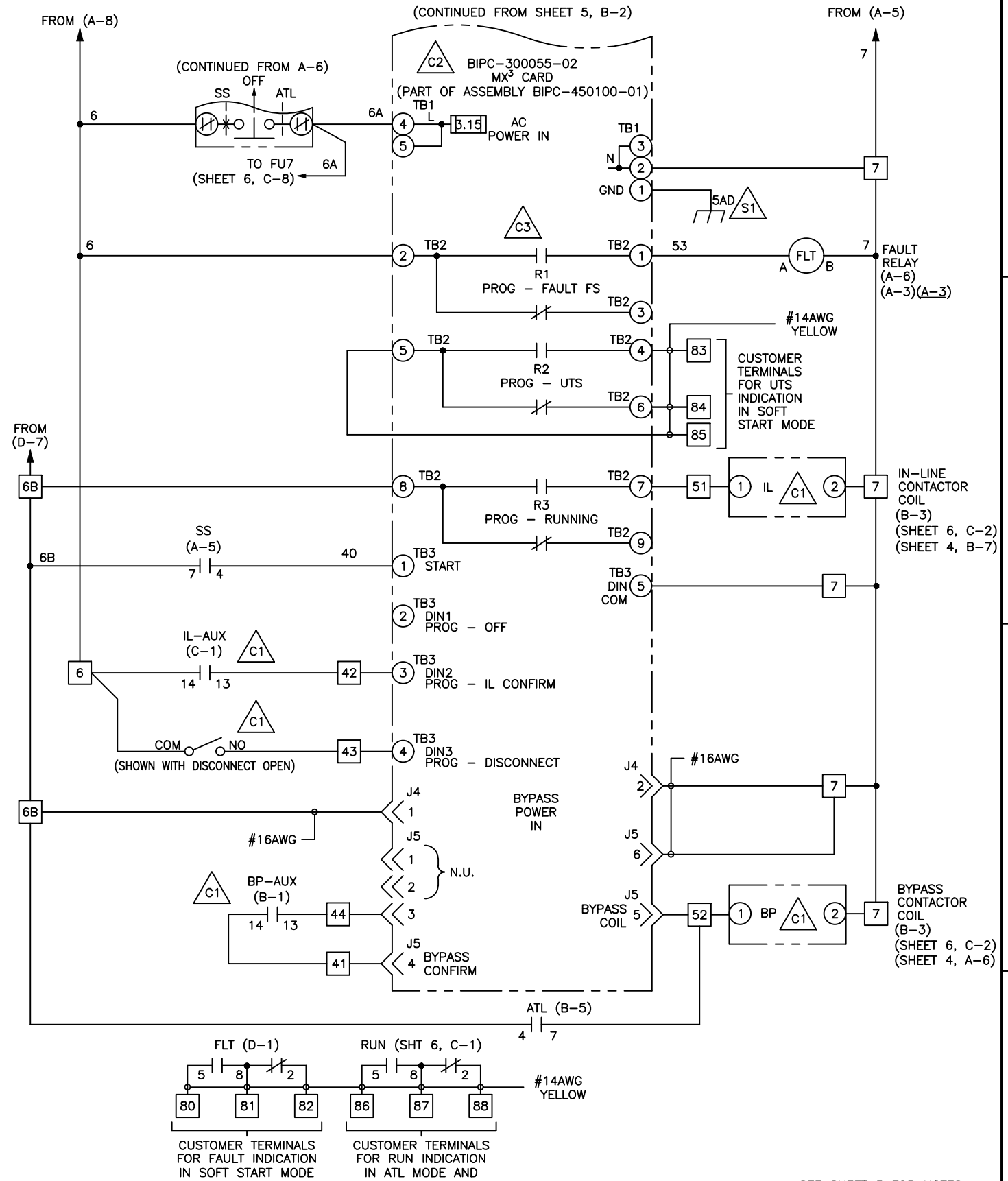
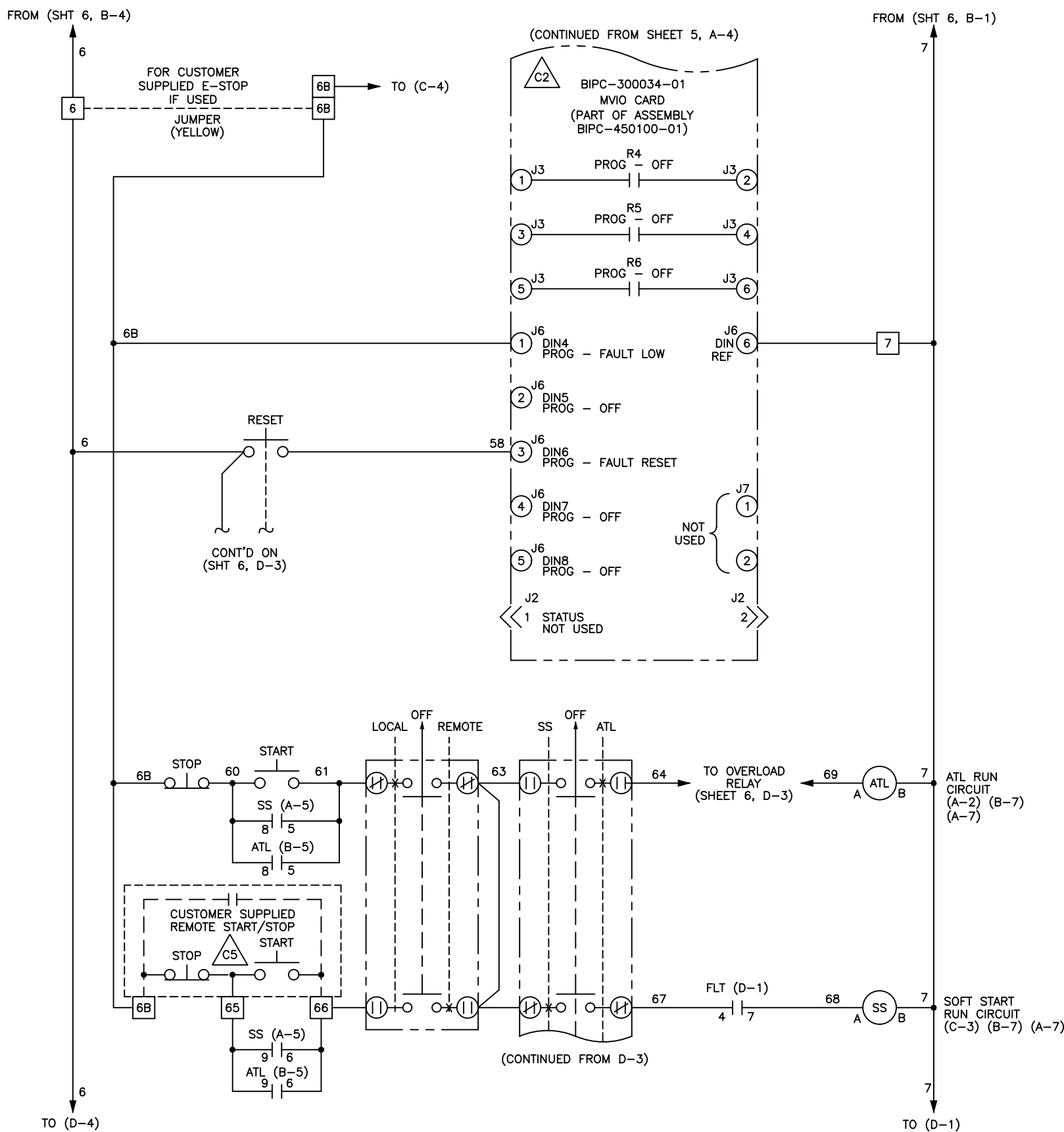

5 ECO #5642 APPRD:JBU 2/25/2020 CHG BY:JBU 2/25/2020 CHANGE: UL 347 UPDATE	4 ECO #5298 APPRD:SNM 11/29/17 CHG BY:RBM 11/29/17 CHANGE: REVISED PER ECO.	3 APPRD:JBU 7/13/16 CHG BY:JBU 7/13/16 CHANGE: GENERAL UPDATE	2 APPRD:JBU 6/2/16 CHG BY:JBU 6/2/16 CHANGE: SHEET 2	1 APPRD:JBU 5/26/16 CHG BY:JBU 5/26/16 CHANGE: GENERAL UPDATE	REVISION DO NOT SCALE DWG	THIRD ANGLE PROJECTION	UNLESS OTHERWISE SPECIFIED ALL DIMENSIONS IN INCHES [mm] INTERPRET DRAWING PER ASME Y14.5M-1994 TOLERANCES: .XX ± .03 .XXX ± .015 ANGLES ± 1°	SIGNATURES DRWN: JBU 5/26/16 CHKD: ENG: JBU 5/26/16	DATE 5/26/16	TITLE: UL LABELED CFMVRMX12-1500-2300-3R SOLID STATE STARTER SCHEMATIC	SEE SHEET 3 FOR NOTES	SCALE: N.A.	SHEET 7 OF 7	REV 5
---	--	---	--	---	------------------------------	------------------------	---	--	-----------------	--	-----------------------	-------------	--------------	-------